

T189

NEW

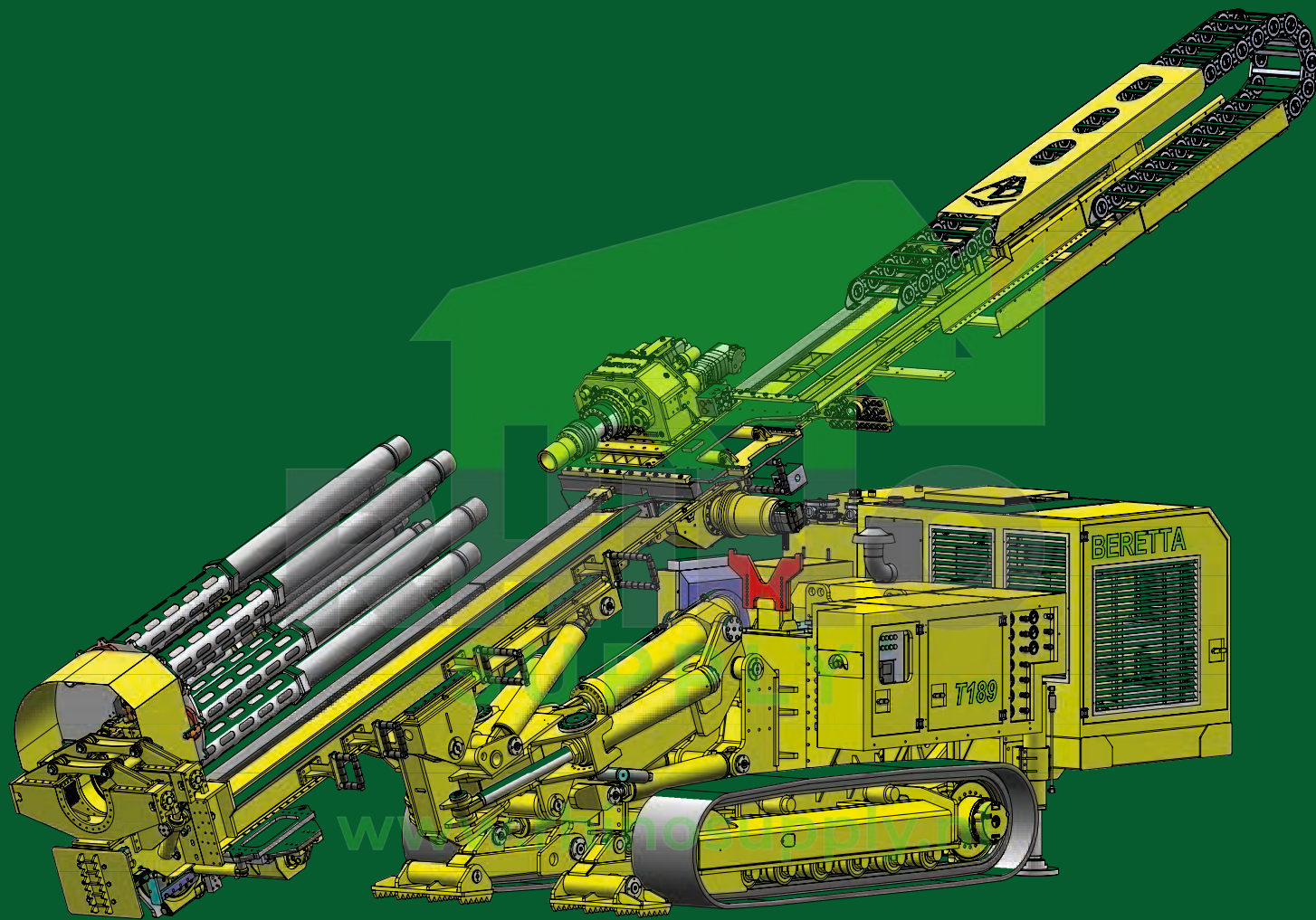

BERETTA®

HYDRAULIC DRILLING RIGS

T189

Innovative Kinematic **PATENTED** - Front the wall

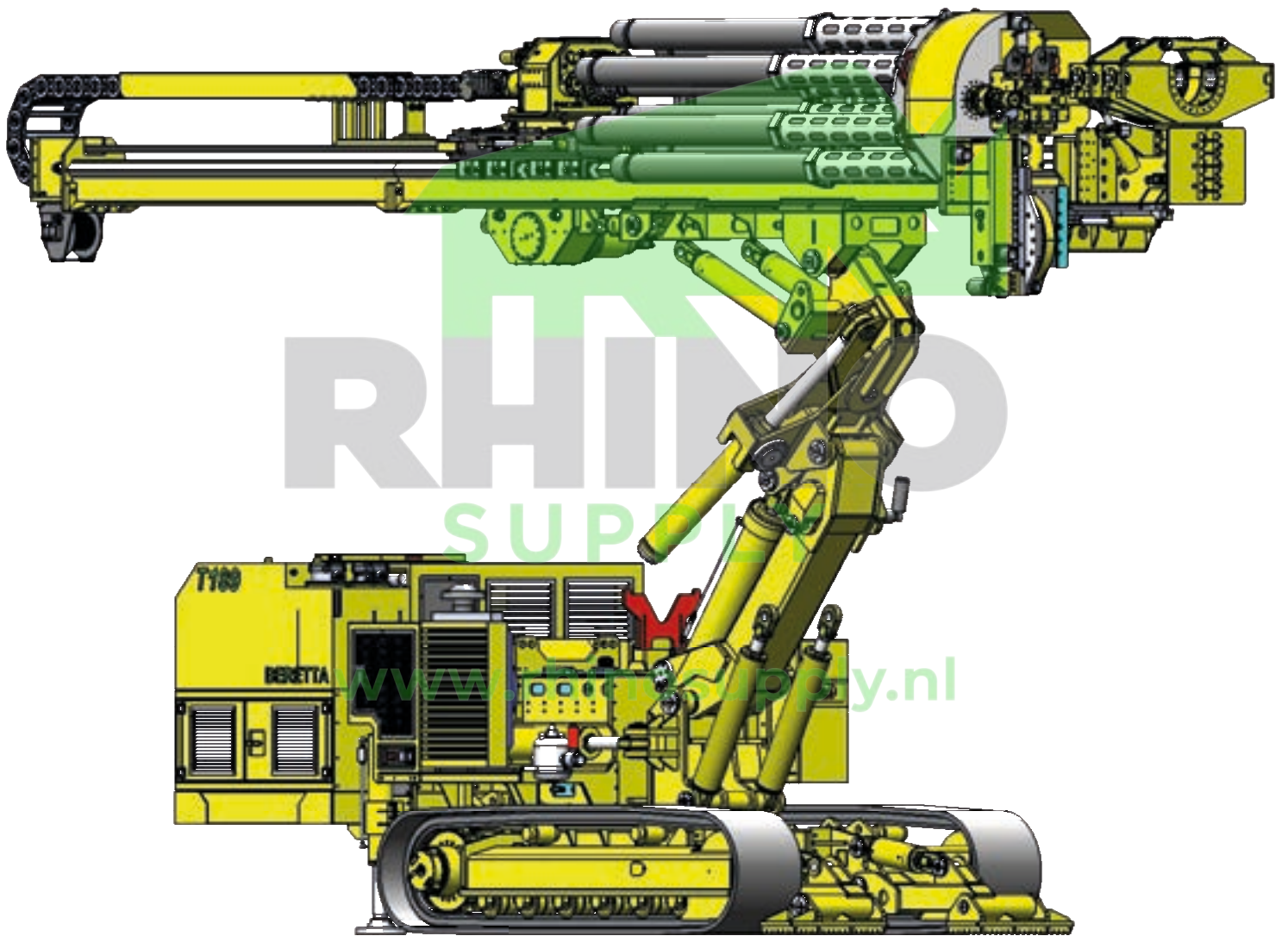

POWER PACK Unità potenza- Unités puissance- питания- Unidad potencia- Leistungseinheit	
Diesel engine Motore Diesel Moteur Diesel Дизельный двигатель Motor Diesel Dieselmotor	Cat - Stage V
Engine power Potenza motore Puissance moteur мощность двигателя Potencia motor Motorleistung	168 KW – 225 HP
Oil tank Sebatoio olio Réservoir d'huile масляный бак Tanque aceite Öltank	600 l ; 158 gal
Fuel tank Serbatoio diesel Réservoir a carburant Топливный бак Depósito de combustible Treibstofftank	250 l ; 66 gal
UNDERCARRIAGE Sottocarro- Chenilles- гусеницы- Orugas- Raupenwagen	
Width Larghezza Largeur ширина Anchura Breite	2420 mm ; 7,93 ft
Wheel base Passo cingolo Empattement Колесная база Distancia de rueda Radstand	2600 mm ; 8,53 ft
Shoes width Larghezza pattini Larghezza patins Ширина обуви Zapatos anchos Schuhbreite	500 mm ; 19,68 in
Max gradeability Pressione suolo Pression au sol давление на грунт Presion suelo Bodendruck	35%
Max speed Velocità max. Vitesse max. Макс. скорость Velocidad max. Max. Geschwindigkeit	1,5 km/h ; 0,90 mph

MAST - Mat- Мачта- Mastil	
Feed stroke Corsa utile Course utile ход вращателя Carrera Vorschublänge	7300 mm ; 24 ft
Total length Lunghezza totale Longueur totale Общая длина Largo total Gesamtlänge	9800 mm ; 32,15 ft
Pull-up Tiro-spinta Traction Маск. тяговое усилие Tiro Vorschubkraft	10.000 daN (opt. 15.000 - 20.000) 22,500 lbs (opt. 33.700 - 44.900)
CLAMPS Morsa- Mors-тиски- Mordaza	
Clamping diameter Diametro bloccaggio Diamètre blocage диаметр захвата тисков Diametro bloque Durchmesser Sperre	45 - 335 (opt. 435) mm ; 1,80 - 13 (opt. 17,12) in
Clamping force Forza chiusura Force fermeture усилие зажима Fuerza cierre Schließkraft	205 KN ; 46000 lbs 280 KN ; 63000 lbs
Break-out torque Coppia svitamento Couple deserrage момент развинчивания Par desenroscado Anzugsmoment	3500 daNm ; 25,80 lbft 4800 daNm ; 35,40 lbft
WEIGHT 21000 - 24000 kg ; 46300 - 53000 lbs Peso- Poids- Bec- Gewicht	
English	Italiano
Français	русский
Español	Deutsch

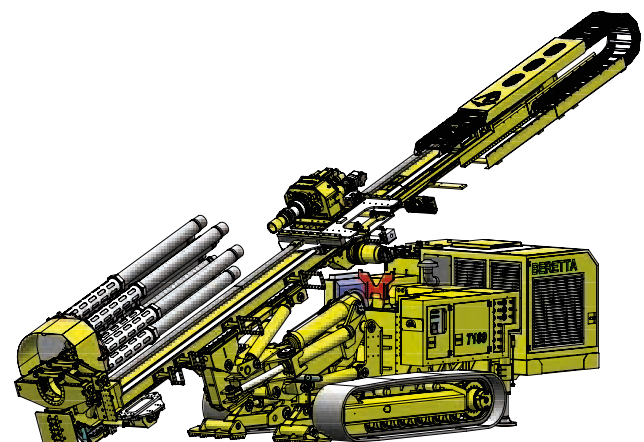

T189

Transport

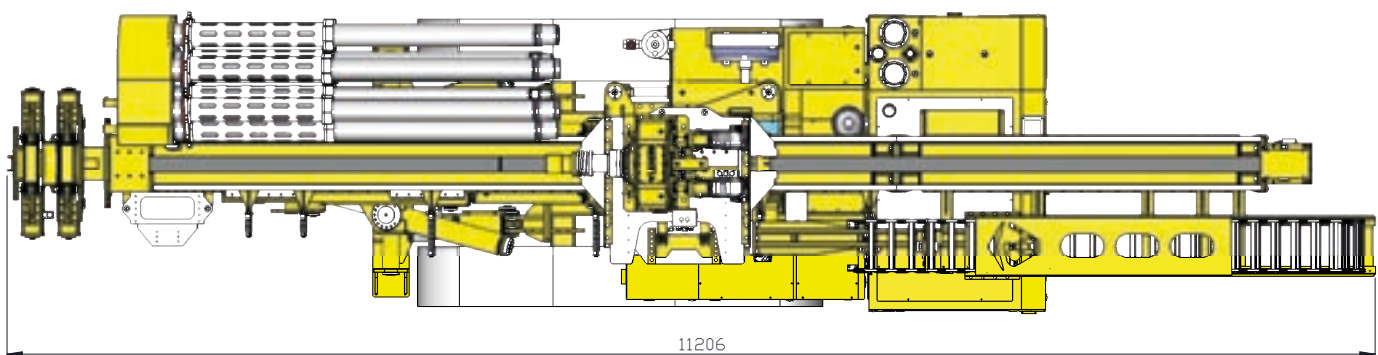
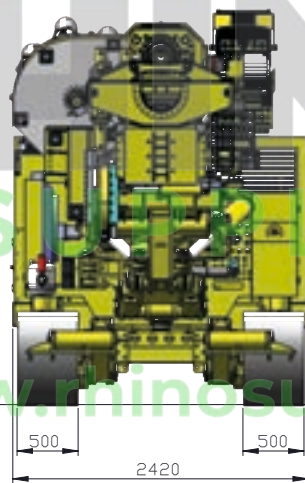
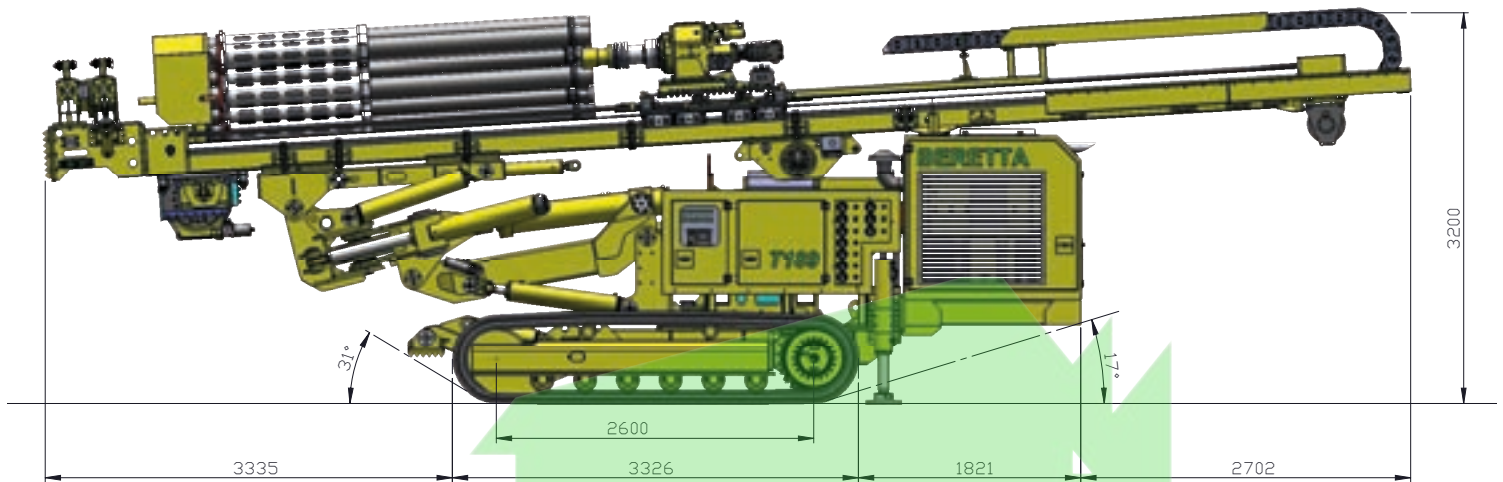

Overall

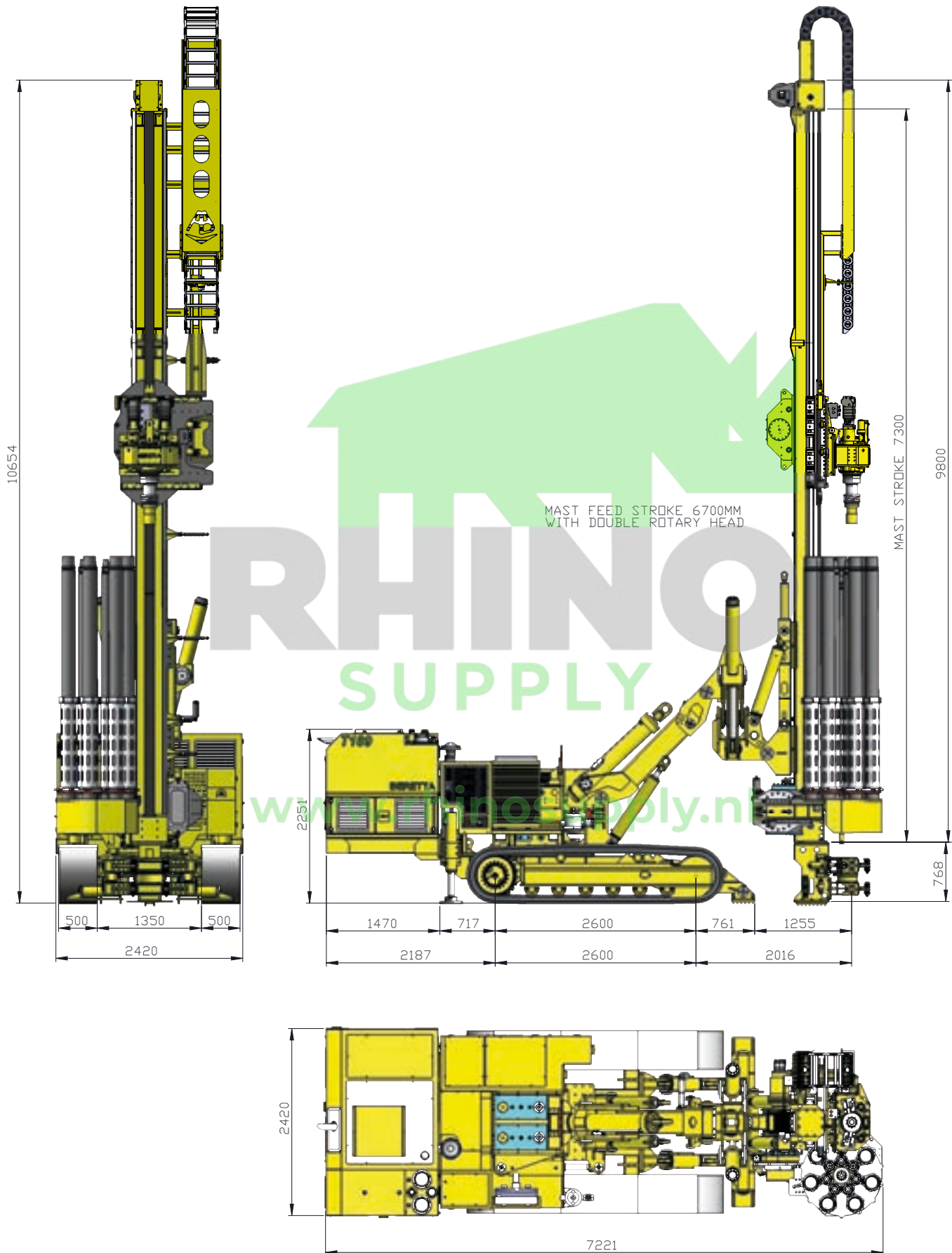

T189





T189

Rotary heads - Testa rotazione - Tête rotation - вращатель - Cabeza rotacion - Rotationskopf

Rotary head		
Testa rotazione- Tête rotation- вращатель - Cabeza rotacion- Rotationskopf		
type 54-1500		
Gears	Torque [daNm] (lb ft)	RPM
I	2150 - (16000)	30
II	1450 - (10700)	46
III	1050 - (7750)	61
IV	715 - (5300)	92
type 55-6V		
Gears	Torque [daNm] (lb ft)	RPM
I	2500 - (18500)	28
II	1550 - (11450)	46
III	1250 - (9200)	56
IV	600 - (4400)	121
V	300 - (2200)	243
VI	200 - (1500)	365
type RMS 515-F		
Gears	Torque [daNm] (lb ft)	RPM
I	4600 - (34000)	15
II	3300 - (24300)	20
III	2350 - (17300)	30
IV	1600 - (11800)	40



Double Rotary head				
Testa rotazione doppia- Double tête rotation - двойной вращатель - Doble Cabeza rotacion- Doppelt Rotationskopf				
	Туре / Тиро / тип / Typ	Gears / Marcie / Vitesses / шестерни / Gange	Max torque [daNm] (lb ft)	Max RPM
Upper head	54-1500	4	2150- (16000)	92
	55-6V	6	2500- (18500)	365
Lower head	RMS -415	4	3150- (23200)	80

www.rhinosupply.nl



Address: Via Parini, 24 - 20842 Besana Brianza (Mb) - ITALY
Tel. +39.0362.995380

www.berettaalfredo.it - info@berettaalfredo.it