

FMC Technologies

Eo4 Piston Pump Data

6.7 BHP Continuous Duty (8.5 BHP Intermittent Duty)

Eo4

Standard Cast ISO Drawing

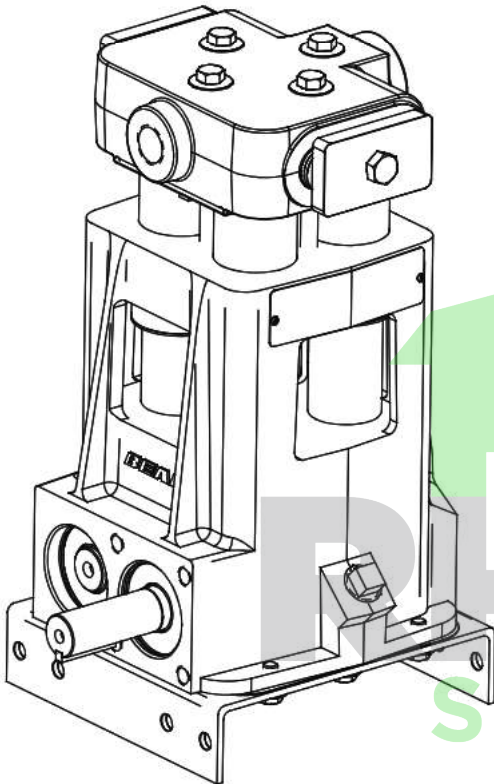

Specifications

Pump Model	Eo4
Configuration	Verticle Quadruplex Piston
Number of Pistons	4
Stroke Length	1.0 Inches
Frame Load Rating	1,240 lbs
Pump Weight (Average)	80 lbs
Direction of Rotation	Either
Internal Gear Ratio	1:1
Intermittent Duty Speed Rating	575 RPM
Continuous Duty Speed Rating	450 RPM
Ball Valve Max Speed Rating	NA
Minimum Speed	390 RPM
Mechanical Efficiency	85%
Lubrication System (Standard)	Splash, Gravity Return
Lube Oil Capacity	1 Quart
Lube Oil Type	SAE 30
Maximum Fluid Temperature	140 °F (250 °F Capability)
Minimum Fluid Temperature	0 °F (-20 °F Capability)
Standard Suction Size	1.25 Inch NPT
Standard Discharge Size	0.75 Inch NPT
Fluid End Material	Cast Iron, Aluminum Bronze
Valve Types	Disc Valves
Hydraulic Motor Mount	SAE A - 2 Bolt with 1"-6B

Performance Table

Pump Model	Piston Diameter (in)	Displacement (GAL/REV)	Maximum Pressure (PSI)	Pump Capacity (GPM) @ Input Speed (RPM)				
				390 RPM	400 RPM	425RPM	450RPM	575 RPM
E0410	1.250	0.0212	1,000	8.29	8.50	9.03	9.56	12.22
E0411	1.375	0.0257	800	10.03	10.28	10.93	11.57	14.78
E0413	1.625	0.0359	600	14.01	14.36	15.26	16.16	20.65

* Horsepower based on 85 or 90% mechanical efficiency. Actual application horsepower requirements can be calculated using the equation: $BHP = (GPM * PSI) / (1714 * 0.85 \text{ or } 0.90)$

* Pump capacities shown are based on 100% volumetric efficiency.

* Dimensions shown are for general sizing purposes and should not be used for construction. Contact FMC for actual dimensions of pump ordered.

* FMC reserves the right to modify this information without prior notice.

Eo4 Cast Pump Engineering Dimensional Outline

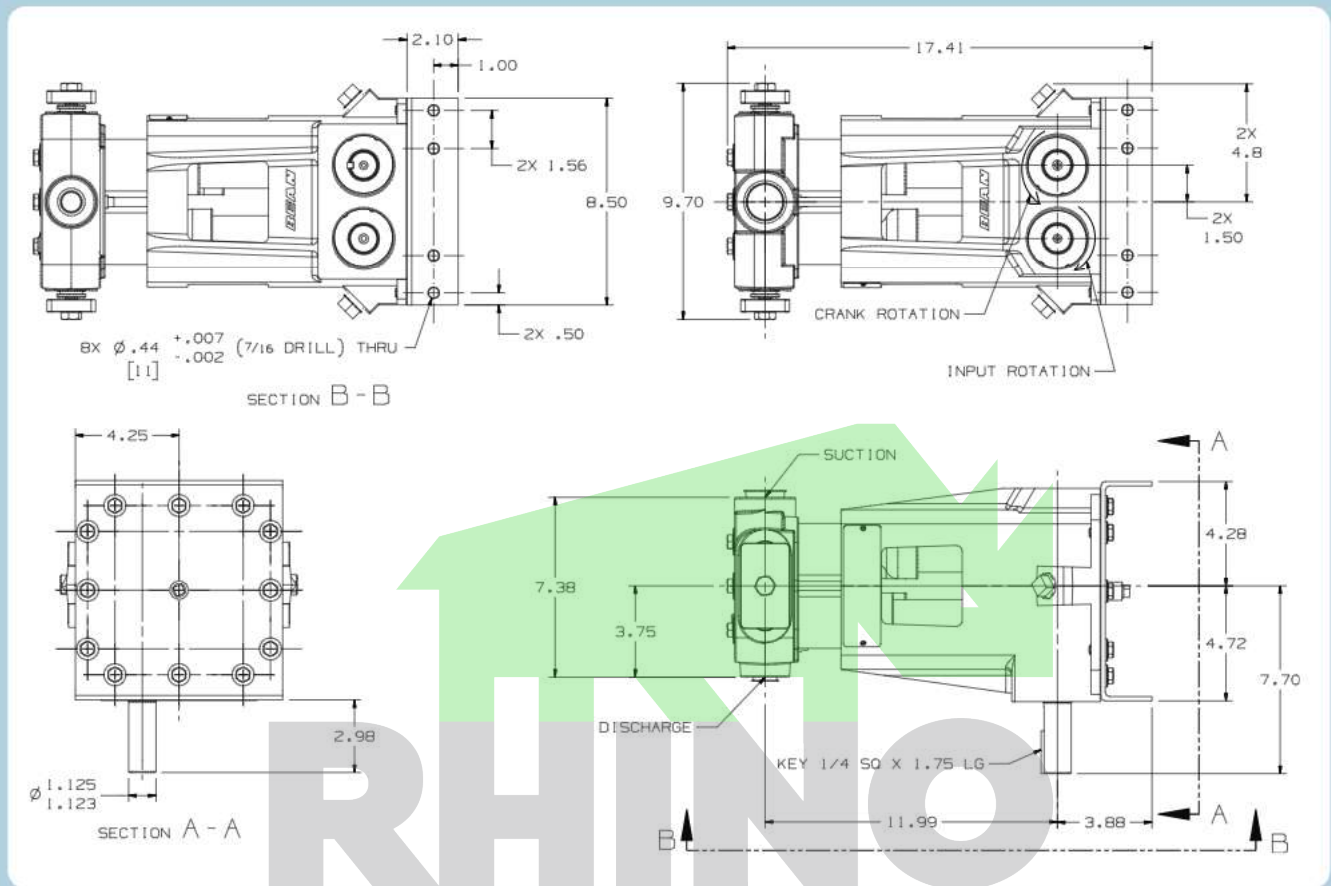

Eo4 NPSHr value for Standard Disc Valves

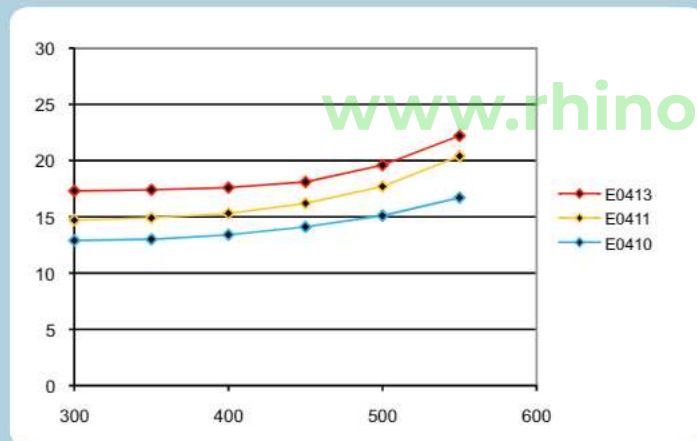

- FMC recommends NPSHa (available) exceeds NPSHr (required) by 5 feet of water.
- Take special consideration when calculating NPSHa. Recalculate NPSHa after pump model has been selected for more accurate values.
- NPSHr values are in feet of water. If you are pumping a different liquid than water, convert the required NPSH from water to the liquid being pumped by dividing the published NPSHr value by the specific gravity of the liquid being pumped.
- FMC published NPSHr values are based on test data collected on specific pumps at the factory and are estimated values. Actual NPSHr values for an ordered pump can only be determined by a factor test. For NPSH critical applications, contact the factory for additional information and request an NPSHr test performed on your pump before shipment.
- Pump drawing dimensions in inches.

For additional information visit FMCPumps.com