

M16 Plunger Pump Data

117 BHP Continuous Duty (142 BHP Intermittent Duty)

Forged ISO Drawing

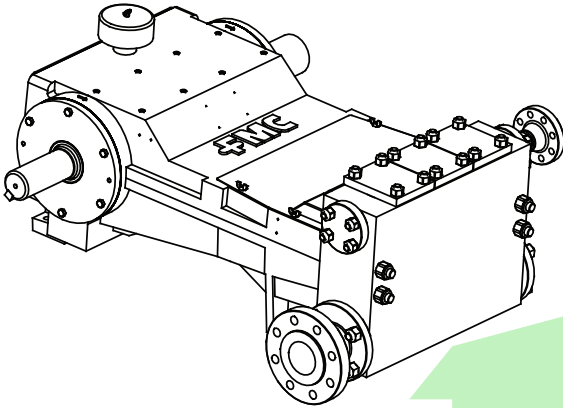

Cast ISO Drawing

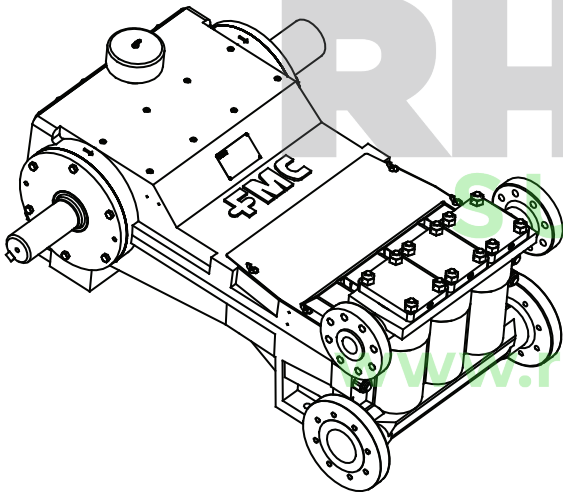

Specifications

Pump Model	M16
Design Standard	API-674, Second Edition
Configuration	Horizontal Triplex Plunger
Number of Plungers	3
Stroke Length	4.0 Inches
Frame Load Rating	9,800 lbs
Forged Fluid Cylinder Pressure Rating	10,000 psi
Cast Fluid Cylinder Pressure Rating	3,000 psi
Pump Weight (Average)	2,400 lbs
Intermittent Duty Speed Rating	425 RPM
Continuous Duty Speed Rating	350 RPM
API-674 Max Recommended Speed	350 RPM
Minimum Speed *	100 RPM
Mechanical Efficiency	90%
Lubrication System (Standard)	Splash, Gravity Return
Lubrication System (Optional)	Pressurized, Motor or Crank Driven
Lube Oil Capacity	10 Gallons
Lube Oil Type	SAE 30
Maximum Fluid Temperature	200 °F (400 °F Capability)
Minimum Fluid Temperature	-20 °F (-50 °F Capability)
Valve Types	Disc Valves, Abrasion Resistant Valves

* Slower RPM can be achieved with the addition of a pressurized lubrication system

Forged Fluid End Material	Cast Fluid End Material
A105 Carbon Steel	Ductile Iron
A350-LF2 Carbon Steel	Nickel Aluminum Bronze
316L Stainless Steel	316L Stainless Steel
2205 Duplex Stainless Steel	2205 Duplex Stainless Steel
Alloy Steel	

* Special Materials available on request

Standard Connection Sizes	Suction	Discharge
M1609-M1618	3.0	1.5
M1618-M1636	4.0	2.0
M1628-M1636	6.0	3.0

* NPT Connections Available

- Consult FMC for specific exceptions to API-674 and NACE standards.
- Consult FMC for any application where inlet pressures will exceed 10% of rated discharge pressure.
- Horsepower based on 90% mechanical efficiency. Actual application horsepower requirements can be calculated using the equation: $BHP = (GPM * PSI) / (1714 * 0.90)$
- Direction of rotation is the top of the crankshaft towards the fluid head.

M16 Performance Table

Pump Model	Plunger Diameter (in)	Displacement (GAL/REV)	Maximum Pressure (PSI)	Pump Capacity (GPM) @ Input Speed (RPM)					
				100 RPM	200 RPM	300RPM	350RPM	400RPM	425RPM
M1609	1.125	0.0516	10,000	5.2	10.3	15.5	18.1	20.6	21.9
M1610	1.250	0.0637	8,000	6.4	12.7	19.1	22.3	25.5	27.1
M1612	1.500	0.0918	5,500	9.2	18.4	27.5	32.1	36.7	39.0
M1614	1.750	0.1249	4,065	12.5	25.0	37.5	43.7	50.0	53.1
M1616	2.000	0.1632	3,115	16.3	32.6	49.0	57.1	65.3	69.4
M1618	2.250	0.2065	2,460	20.7	41.3	62.0	72.3	82.6	87.8
M1620	2.500	0.2550	1,990	25.5	51.0	76.5	89.3	102	108
M1622	2.750	0.3085	1,650	30.9	61.7	92.6	108	123	131
M1624	3.000	0.3672	1,385	36.7	73.4	110	128	147	156
M1626	3.250	0.4309	1,180	43.1	86.2	129	151	172	183
M1628	3.500	0.4998	1,015	50.0	100	150	175	200	212
M1630	3.750	0.5737	885	57.4	115	172	201	229	244
M1632	4.000	0.6528	775	65.3	131	196	228	261	277
M1634	4.250	0.7369	650	73.7	147	221	258	295	313
M1636	4.500	0.8262	570	82.6	165	248	289	330	351

M16 NPSHr values for Disc Valves with 2-springs

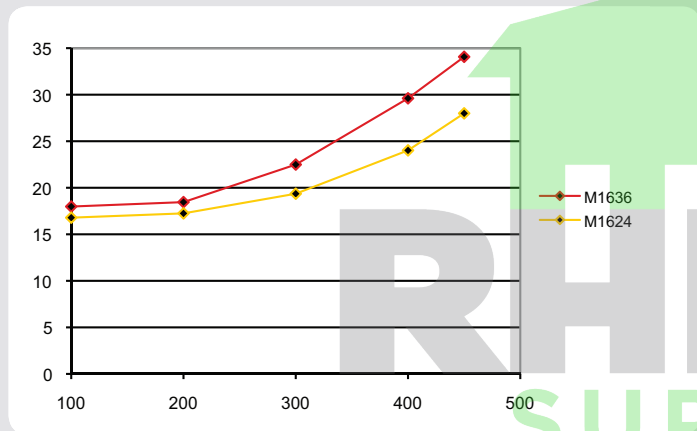

M16 NPSHr values for AR Valves with 1-spring

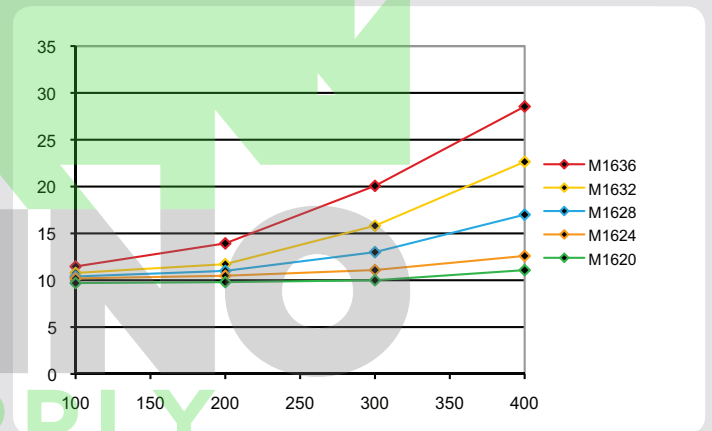

M16 NPSHr values for Disc Valves with 1-spring

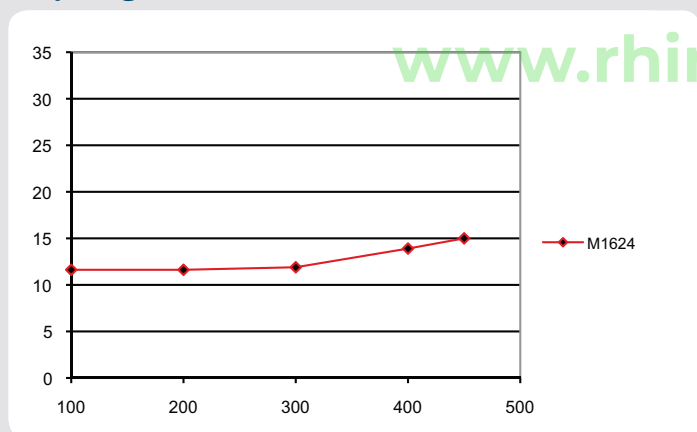

www.rhinosupply.nl

- Pump capacities shown are based on 100% volumetric efficiency.
- FMC recommends NPSHa (available) exceeds NPSHr (required) by 5 feet of water.
- Take special consideration when calculating NPSHa. Recalculate NPSHa after pump model has been selected for more accurate values.
- NPSHr values are in feet of water. If you are pumping a different liquid than water, convert the required NPSH from water to the liquid being pumped by dividing the published NPSHr value by the specific gravity of the liquid being pumped.
- FMC published NPSHr values are based on test data collected on specific pumps at the factory and are estimated values. Actual NPSHr values for an ordered pump can only be determined by a factor test. For NPSH critical applications, contact the factory for additional information and request an NPSHr test performed on your pump before shipment.

M16 Plunger Pump Data

117 BHP Continuous Duty (142 BHP Intermittent Duty)

Forged Pump Engineering Dimensional Outline

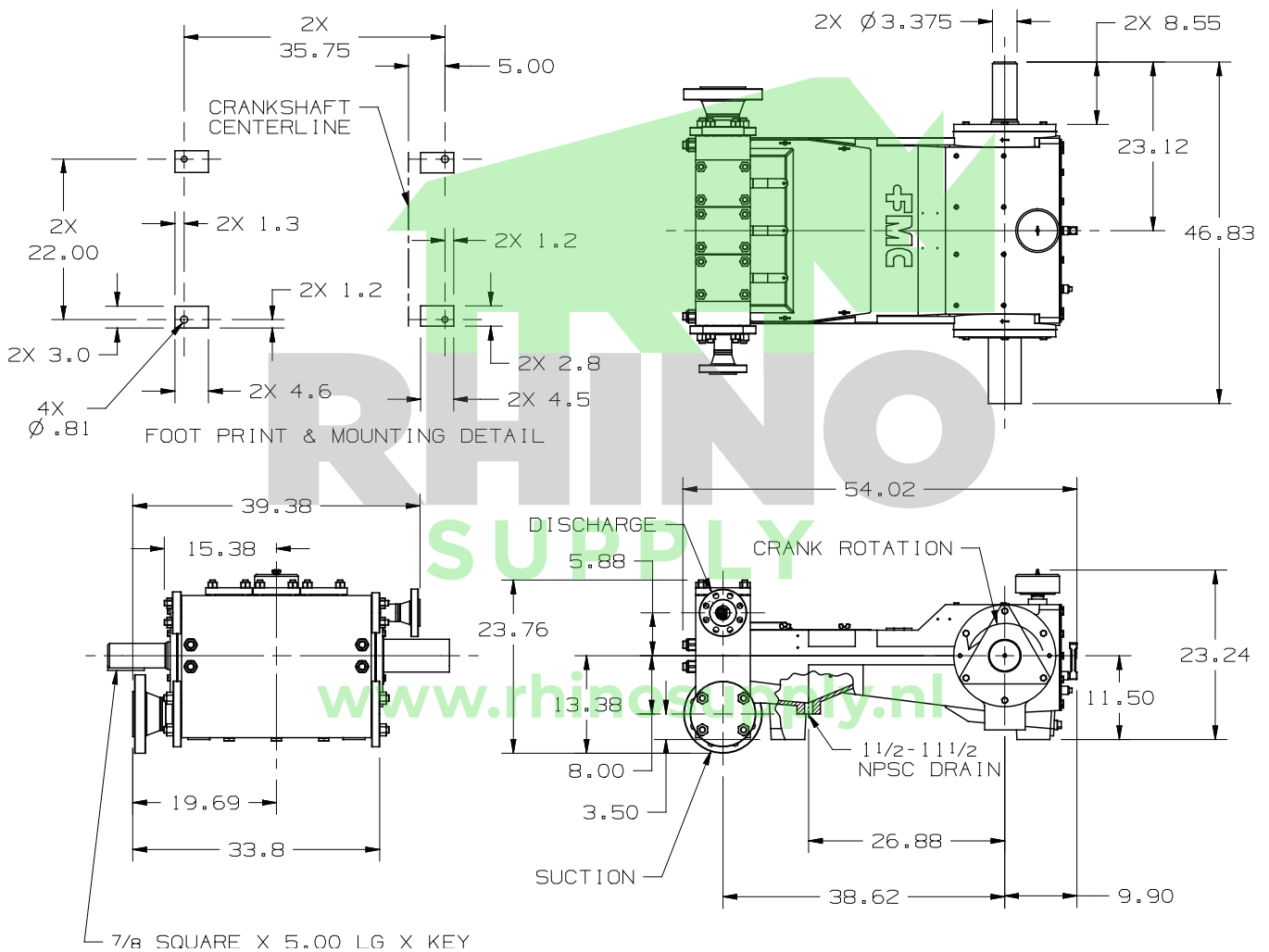

M16 Plunger Pump Data

117 BHP Continuous Duty (142 BHP Intermittent Duty)

Cast Pump Engineering Dimensional Outline

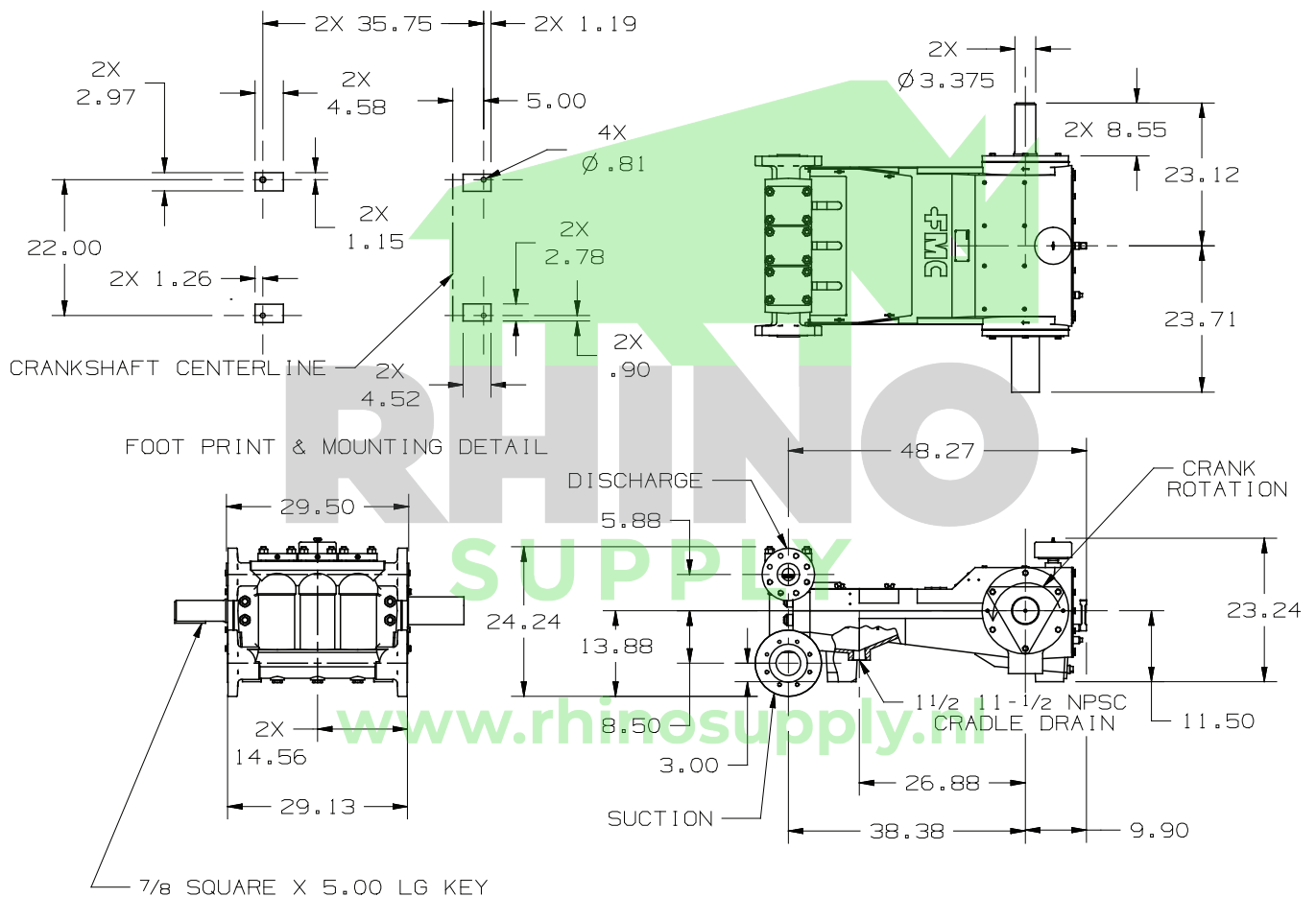

• Dimensions shown are for general sizing purposes and should not be used of construction. Contact FMC for actual dimensions of pump ordered.

• FMC reserves the right to modify this information without prior notice.

• Pump drawing dimensions in inches.