

Parts and Service Manual Kerr KA-3500PT Piston Pump

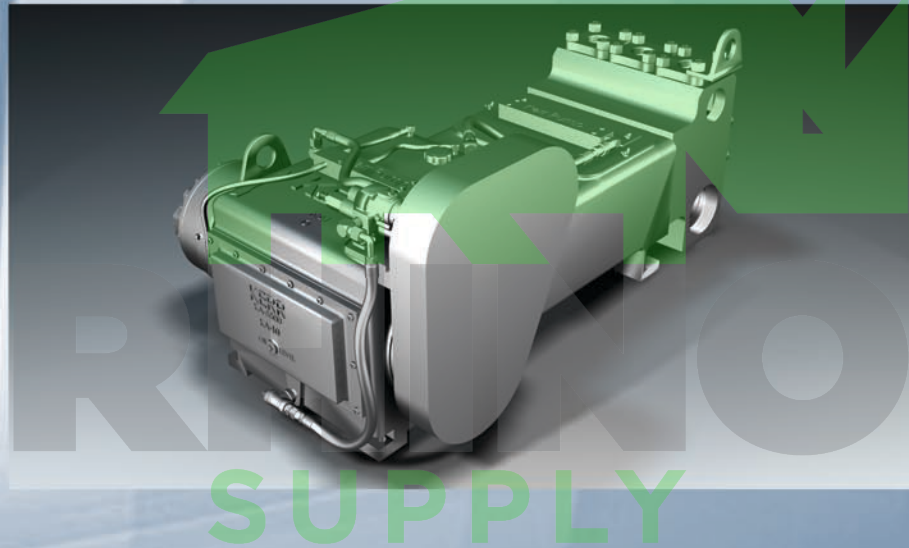

Post Office Box 735 2214 West 14th Street

Sulphur, Oklahoma 73086

Phone: 580-622-4207 Fax: 580-622-4206

Website: www.kerrpumps.com

Email: information@kerrpumps.com

United States and Canada

800-441-8149

Kerr Pumps



Since 1946

NEW PUMP WARRANTY

- 1) Kerr Machine Company (**KERR PUMPS**) warrants its new HDD pumps to be free from defective materials and/or workmanship for 1000 HOURS OR ONE (1) YEAR, whichever comes first, from date of sale by distributor, provided that the new pump is registered in accordance with Paragraph No. 2 hereof, properly installed and operated in accordance with the Company's Service Manual, and all other terms of this warranty agreement are complied with by the purchaser. As hereinafter provided, this warranty includes the replacement of parts and labor to correct any deficiency. All defective parts must be returned to the Company's Home Office for examination before this warranty is effective. This warranty applies to parts, which have been replaced under this warranty only so long as the original pump warranty is effective. This warranty is for the exclusive benefit of the purchaser and is not transferable.
- 2) Each Distributor of a new **KERR PUMP**, will provide the customer with a registration blank furnished to him by the Company which must state the date of sale, be signed by the purchaser and the Distributor, and delivered to the Home Office of the Company within fifteen (15) days of the date of sale.
- 3) In the event of a claim under this warranty, made within the 1000 HOUR warranty period, the purchaser must notify the Distributor, and the Distributor shall contact **KERR PUMPS** before any repairs or service calls are made.
- 4) All warranty claims must be sent to **KERR PUMPS** Home Office on the authorized warranty claim form provided by **KERR PUMPS**, and available from the Distributor before any warranty claim will be considered. It is understood that **KERR PUMPS** will deteriorate due to ordinary wear therefore; the following credits shall apply to all replacement parts, labor, surface freight, travel time and mileage allowance furnished under this warranty.

FOR 1000 HOUR CLAIMS

- A. For the first 250 hours, 100% credit will be allowed on a current list price basis.
- B. From 251 hours to 500 hours, 75% credit will be allowed on a current list price basis.
- C. From 501 hours to 750 hours, 50% credit will be allowed on a current list price basis.
- D. From 751 hours to 1000 hours, 25% credit will be allowed on a current list price basis.

The credit given to the Distributor for replacement parts or pumps under this warranty is based upon the Distributor's net cost paid Kerr Pumps for such replacement parts or pumps.

- 5) In the event of a warranty claim under this warranty made within the first 250 hours, **KERR PUMPS**, before any repairs are made, shall be contacted by the Distributor and given the option of having the Distributor either repair or replace the pump.
- 6) Upon any claim under this warranty, other than a claim wherein **KERR PUMPS** at its option replaced the pump as provided in Paragraph No. 5 hereof, the Distributor will make the necessary repairs an/or replacement, and **KERR PUMPS** shall allow the cost of labor on warranty claims. The labor cost may include travel time not to exceed (8) hours of actual travel time. **KERR PUMPS** will pay surface freight on warranty shipments. After making the necessary repairs and/or replacements, the Distributor will bill the customer for the full amount due for the repair. Thereafter, the Distributor will submit the warranty claim form provided by **KERR PUMPS** to the **KERR PUMPS** Home Office for consideration. In the event the warranty claim is honored by **KERR PUMPS** a Credit Memorandum will be issued to the Distributor in the amount determined by the table in Paragraph No. 4 hereof. Thereafter, the customer's invoice will be credited by the Distributor in the same percentage allowed the Distributor by **KERR PUMPS**.

If requested by **KERR PUMPS** the purchaser or the Distributor shall return the alleged defective product to **KERR PUMPS** factory, freight prepaid, for examination and testing. If **KERR PUMPS** determines the product is defective **KERR PUMPS** will either repair or replace such product with a like of **KERR PUMPS** manufacture, f.o.b. to the Distributor or allow the Distributor credit to an amount equal to the invoiced value of the defective product. The responsibility of **KERR PUMPS** is limited to the repairing or replacing defective material manufactured by it, provided **KERR PUMPS** examination discloses to its satisfaction that such material has not been altered or repaired, other than by **KERR PUMPS** approved procedures, subject to misuse, improper maintenance, negligence or accident. **KERR PUMPS** will not be responsible for loss of liquid or for damage of any kind, or from any cause, to any person or property of any person, or for loss of revenue of profit, or for any other special incidental or consequential damages.

- 7) The warranty applies only to new **KERR PUMPS**. The Company specifically excludes from this warranty the following.
 - A. All pistons, piston rubbers, liners, valves, valve springs, seals gaskets, and corrosion and/or erosion damage caused by the fluid handled by the Company's pump.
 - B. In addition, after the expiration of the pump warranty all replacement parts are no longer in warranty.
- 8) In extreme cases where in the opinion of **KERR PUMPS**, if a pump has been misused or is being misused, **KERR PUMPS** reserves the option to offer to redeem the pump from the purchaser. Should the purchaser refuse to allow the pump to be redeemed and chooses to continue improper operation, the warranty will be void.

- 9) Any parts or equipment which **KERR PUMPS** supplies and does not manufacture shall be subject only to the warranties of **KERR PUMPS** vendors to the extent **KERR PUMPS** can enforce such warranties.
- 10) Any repairs to, alterations of, or work done on alleged defective products without **KERR PUMPS** specific written authorization shall void **KERR PUMPS** warranty applicable thereto.
- 11) Any action for breach of warranty or other action under this agreement must be commenced within (1) year after such cause of action arises.

This limited warranty is in lieu of all other warranties, expressed or implied, including any implied warranty or merchantability or fitness.



www.rhinosupply.nl

KERR TROUBLE SHOOTER GUIDE

	REASON OR SERVICE NEEDED
Unusual pounding, knocking broken valve spring	Insufficient fluid at high speed. Check to see if the suction line is the proper size and is not constricted trash in line, valve partly opened, etc. There is also a possibility of gas in the fluid causing the roughness.
Loss of pressure or volume	Also above. Foreign matter may be holding valves open. Worn valves. Broken springs.
Consistent, rhythmic knock	Improper bearing adjustment. Worn bearings or connecting rods. NOTE: Valve noise is common and normal in high-speed pumps. It should not cause concern unless it becomes erratic.
Packing failure (Excessive)	Improper installation. Improper type lubrication. Incorrect type packing for particular installation. (Contact KERR PUMPS if in doubt) Excessively worn plungers.
Abnormal wear of fluid end parts	Abrasive or corrosive fluid.
Abnormal wear of power end parts	Lack of oil, overload on pump, foreign matter in oil.
Heat in power end	A new pump will run hot for a short period (2 or 3 days). Check above for persistent heating. Pump will operate near 140° F. under average conditions. Check for air in pump by bleeding at cover caps. Too much spring tension Reciprocating pumps have very limited pick up, check installation section.

INSTALLATION INSTRUCTIONS (SEE ILLUSTRATION)

The importance of proper installation cannot be overstressed. As the reciprocating pump is almost unable to lift fluid, proper suction flooding is a must. This is the First step toward satisfactory operation.

The **KERR PUMPS** Engineering Service will gladly advise you in your installation problems. As almost every installation varies, you cannot exercise too much care in making certain your installation is proper.

Before Starting the Pump, read carefully the maintenance section in the following pages.

To start the pump, open the suction line valve and permit the intake chamber to fill on the pump. Air may be bled off by opening the valve covers slightly until there is a constant fluid flow. After bleeding, open the discharge line valve and start the pump. Roughness may occur from cavitation (air in line) or from starvation (lack of fluid). Eliminate these troubles before permitting continuous operation.



www.rhinosupply.nl

**RECOMMENDED INSTALLATION OF KERR PUMPS
FOR BEST RESULTS**

(A)	PRESSURE RELIEF VALVE (REQUIRED)
(B)	BY-PASSED FLUID SHOULD BE PIPED BACK IN SUCTION SUPPLY TANK WHEN POSSIBLE
(C)	USE FLEXIBLE HOSE IN DISCHARGE LINE WHEN POSSIBLE
(D)	DISCHARGE SHUT-OFF VALVE (OPTIONAL-USED FOR TOTAL SHUT-DOWN OR SERVICE ONLY)
(E)	DISCHARGE AND SUCTION ON EITHER SIDE OF FLUID END ON ALL MODELS.
(F)	PULSATION “DAMPENERS” MAY BE USED IN EITHER THE SUCTION OR DISCHARGE PIPING OR BOTH. DISCHARGE DAMPENERS SHOULD BE CAPABLE OF HANDLING PUMP DISCHARGE MAXIMUM PRESSURE

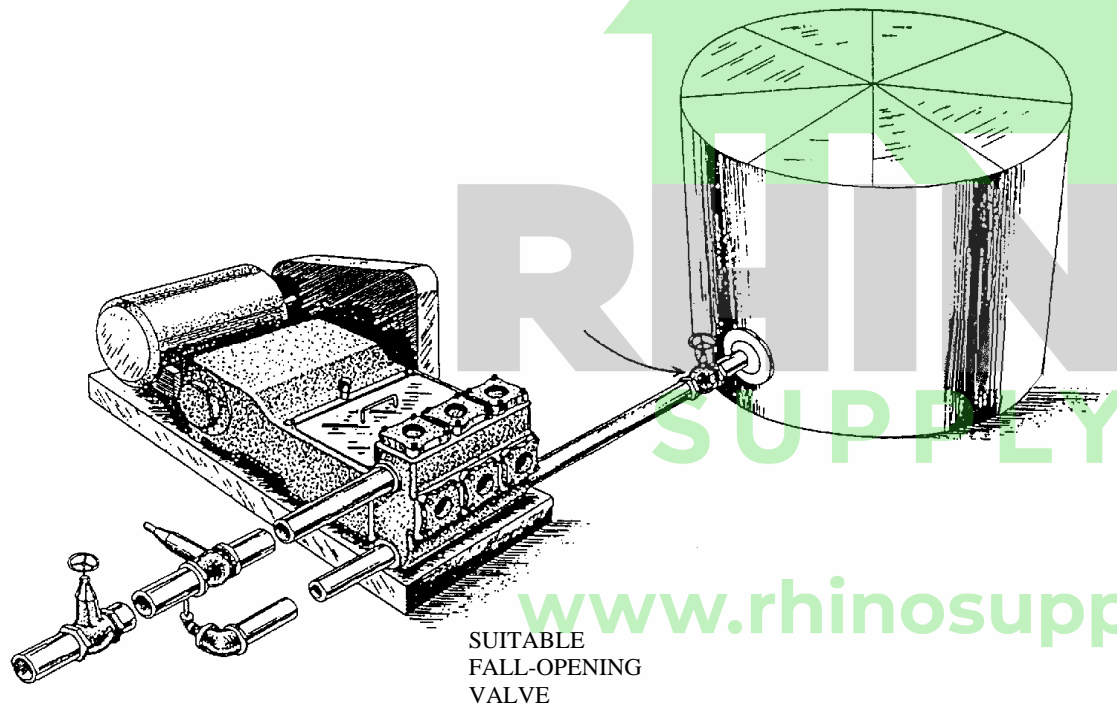

SUITABLE
FALL-OPENING
VALVE

AS A GENERAL RULE, FLUID LEVEL MUST BE HIGHER THAN THE PUMP FLUID END AS PLUNGER PUMPS CANNOT “LIFT” FLUID. ABOUT 10 FEET OF HEAD IS A GOOD “RULE OF THUMB”.

INSTALL PUMP AS CLOSE TO TANK AS POSSIBLE

CAUTION SHOULD BE TAKEN TO KEEP FITTINGS OUT OF THE SUCTION AND DISCHARGE PIPING AS THESE WILL RESULT IN POOR PERFORMANCE. EACH 90-DEGREE TURN IN THESE LINES RESULTS IN GREAT LOSS OF PUMPING EFFICIENCY.

PREVENTIVE MAINTENANCE

DAILY

1. Check and Maintain Lubricant Levels.

Standard Lubricant:

AGMA Grade (ASTM D 2422): 4 EP

ISO Viscosity Grade: 150

Viscosity in SSU @ 100 degree F: 625-765

Synthetic Lubricant:

SAE Viscosity Grade (J306-8): 75W-90

PUMP CAPACITIES (APPROXIMATE)

KM-3250PT	4 qts.	KT-3350PT	16 qts.
KM-3300PT	4 qts.	KT-3400PT	16 qts.
KP-3300PT	12 qts.	KA-3500PT	20 qts.
Q5450DPT	22.5 qts.	Q5500DPT	22.5 gal.
KZ-3150PT	2 qts. Use SAE 30 weight non-detergent motor oil		

PLANETARY GEAR REDUCERS

#6 AUBURN	17 ozs.
#8 & #9 AUBURN	42 ozs.

2. If pump has lubricating facilities for stuffing boxes, check level of lubricant.
3. Maintain packing gland tension on packing (Do not over-tighten)
4. Visually inspect pump for apparent trouble.
5. Keep the pump clean.

MONTHLY

1. Drain and refill crankcase. It is recommended that oil be changed after the first week of operation.
2. Wash oil filler cap in kerosene.
3. Check valves for excessive wear, broken or bent springs, etc.
4. Check crankshaft bearings for endplay. (See section on crankshaft)
5. Keep all nuts, studs, etc. tight.
6. Check valve covers for leaks.
7. Check all seals and gaskets for leaks

GENERAL

Replace any work part before its eventual failure. Use the following instructions for removal and replacement of parts. Don't hesitate to call on **KERR PUMPS** for help if necessary.



www.rhinosupply.nl

SERVICE PROCEDURES (ALL MODELS)

1. VALVES (Wing-guided type):

- A. Discharge Valves: The discharge valve and seat can be exposed by first removing the discharge valve cover cap. Once the discharge cover cap has been removed you may lift out the discharge valve spring and the discharge valve. The valve seat will be held in place by a taper fit and must be “pulled” with an appropriate valve-pulling tool (available from the **KERR PUMPS** Dealers). Once the valve and seat have been removed they should be resurfaced or replaced if badly worn. To replace the discharge valve, first clean and inspect the seat bore for washout defects and then drop the seat into the bore. Replace the valve into the seat and strike the top of the valve a couple of good blows utilizing a brass bar and hammer to seat the valve seat in the fluid end valve bore. Replace the valve spring and cover cap after inspecting the spring and the seal of the cover cap.
- B. Suction Valves: The suction valves are located in the chamber directly behind the suction or end valve cover caps. The suction valves are serviced in the identical manner as the discharge valves. Note: Discharge valves must be removed prior to any removal of the suction valves.

Service Procedure for KZ-3150PT Valves

- C. **DISCHARGE VALVE:** *The discharge valve and seat can be exposed by first removing the discharge valve cover plate. Once the discharge cover cap has been removed you may lift out the discharge valve spring, discharge valve and valve seat. Once the valve and seat have been removed they should be replaced if badly worn. To replace discharge valve, first clean and inspect the seat bore for wash out defects and then drop the seat into the bore. Replace valve in seat then valve spring and cover cap, always-inspecting O-ring seals between seats and cover caps.*
- D. **SUCTION VALVE:** *The suction valves are located in the chamber directly below the discharge valve seat. The suction valves are serviced in the identical manner as the discharge valves.*

www.rhinosupply.nl

2. PONY ROD and PONY ROD PACKING: **KERR PUMPS** use two pony rod sealing arrangements, models KM-3250PT and KM-3300PT use a screw in seal gland, all other models use a bolt in seal gland, these glands use press in oil seals with snap ring retainers. Some Bolt in gland use adjustable packing arrangements with bolt in or screw in followers to adjust packing. By unscrewing plunger from pony rod a gap may be facilitated to allow the removal of the various sealing arrangements. A special wrench will be needed to remove and replace pony rod to crosshead. (This wrench is available from **Kerr Dealers**)

All pony rods have a jam nut to align tighten pony rod to crosshead, care must be exercised in installing new seal on pony rod not to damage it.

3. **DISASSEMBLY OF POWER END.** (CAUTION: Prior to disassembly of any power end, the plunger, pony rod, and pony rod seal housing must be removed.) Expose the crankshaft and connecting rods by removing the pan cover. Connecting rod caps may now be removed and the connecting rod and crosshead should be shoved all the way to the rear (toward the fluid end) to facilitate crankshaft removal out either side as convenient. The connecting rods and crossheads may now be taken out the front cavity exposed by removing the crankshaft. Connecting rods may be removed from the crosshead by loosening the setscrew and driving out the wrist pin from the crosshead. A bronze bushing is used in the rod it may be driven out of the rod and replaced with a new bushing. Reassembly is the reverse of the above outlined sequence with the following considerations for “fits” or tolerance:
 - A. General: All Kerr components are machined on modern production machine tools and are of the same specifications and close tolerances you would expect in a modern automobile engine. It must be pointed out that at top speed (350 to 400 RPM) your pump will not even be approaching idle speed for a gasoline engine so “field fits” are possible and practical when making repairs and replacements away from the factory. All procedures outlined below are possible with only hand tools and absolutely no instruments, special tools, or gauges are needed.
 - B. Connecting rod and wrist pin: Proper fit will find the wrist pin turning freely in its bore in the connecting rod, but it should have no “wobble” that is discernable up and down the main axis of the connecting rod. This looseness in the wrist pin fit is the most probable cause of “knocking” which is traceable to the power end of most all pumps. The only solution for loose fitting wrist pins is to discard the connecting rod wrist pin bushing and replace with a new one. If any wear is visible on the wrist pin it should always be replaced.
 - C. Crankshaft End Play and Lateral adjustments: Adjustment of the Taper Roller bearings used in all Kerr Pumps is accomplished by removing or adding shims under the bearing housing. Shims are taken out or added until the crankshaft (without connecting rods) will turn freely, but with no endplay felt when attempting to pull or push the jackshaft end of the crankshaft along its long axis. Some lateral adjustment is possible by removing shims from one side of the crankshaft and adding them to the opposite side. (Note: Lateral adjustment is the “centering” of the crankshaft in the power frame housing.)
 - D. Connecting Rod to Crankshaft fitting: Factory bored connecting rods will normally fit the standard crankshaft journal just by bolting the cap on the rod with the standard rod shims being used. If the caps do require adjustment this is accomplished by removing or adding various thicknesses of rod shims. The standard connecting rod shim used on all

Kerr Pumps is 1/32" thick and is comprised of .002" laminates, which can be "pealed " off separately. Proper fit of the connecting rod will allow the pump crankshaft to be rotated while not allowing in-and-out slack in the connecting rod along its long or main axis. A well-fitted rod will have none of the in-and-out slack, but should be free enough to be moved from side to side on the rod journal. This insures the rod not being too tight. A point of caution when installing the connecting rod assembly in the pump is to make certain the oil holes in the rod are "UP" and not toward the bottom of the pump. This will result in lubrication failure in these parts and the pump will fail in a short period of time. An additionally important step is to make sure that the rod cap is bolted back on the rod as it came off. The rod and cap carry a "mark" or "number" which allows you to match them back properly. Failure to do this will cause the rod not to fit the journal for which it was made.

4. Power End/Fluid End Connection: A common misconception is that there is some form of fluid seal between the power end and the fluid end. This is false. The fluid end is merely bolted to the power frame. To take off the Fluid End all the Liners must be removed by unthreading all retainer Nuts from each retainer Stud, sliding off each liner Retainer, followed by any unscrewing all other power frame to fluid end cap screws, removing the Piston Rod Clamp, then safely sliding the Fluid End away from the Power Frame.

RHINO
SUPPLY

www.rhinosupply.nl



TECHNICAL DATA SHEET

T.D.S. NO. 4.2
Page 1 OF 2
Date 03-10-06

PCN: _____

Supersedes PCN: _____

TITLE: Short Term Storage Preparation Procedure

1.0 SCOPE

This procedure applies to Kerr Pumps ONLY. Storage procedures for any other unit components or accessories (gear reducers, engines, etc.) are to be prepared to the specific manufacturer's recommendations.

1.1 Short-term storage is defined as storage and/or transient time less than six (6) months in an environment defined in Paragraph 2. If storage exceeding six months is expected, the Long Term Pump Storage Preparation Procedure should be followed.

1.2 Kerr Pumps will only prepared for short term storage if so specified in the purchaser or customer order control document.

2.0 STORAGE ENVIRONMENT

A minimal environmental condition, to be met by the customer or purchaser, is a closed shelter to eliminate effects of sun, wind, sand or other debris. Large temperature and humidity changes should be avoided to prevent coating deterioration or contamination by moisture.

3.0 PRESERVATIVE PRODUCT

3.1 **The specified rust preservative will protect the internal power end parts from corrosion due to atmospheric moisture, and may be left in the pump when filled with appropriate lubricant and placed into service. The elevated temperature of service will cause rapid depletion of the preventative protection.**

3.2 The following rust preventative products or their equivalents are recommended for use in Kerr Pumps and usually available in 5 gallon, 55 gallon containers:

CITGO: RUST-O-LINE OIL 10
SHELL: ENSIS OIL N

4.0 PROCEDURE

4.1 Preparation from; factory testing, inventory, or a distributor rebuild facility.

4.1.1 Drain any oil that may be in the power end, and then fill the complete power end cavity with the specified rust preventative. After 15 to 20 minutes, drain the rust preventative back into its storage drum for future use.

4.1.2 Remove and clean oil level gages, pressure gages and breather caps. Replace with pipe plugs in threaded openings.

4.1.3 All breathers shall be replaced with airtight seals, plugs or gasketed plates. No venting is recommended as it may allow moist air in.



TECHNICAL DATA SHEET

T.D.S. NO. 4.2
Page 2 OF 2
Date 03-10-06

PCN: _____

Supersedes PCN: _____

- 4.1.4 Remove the wiper box seals and cap/plug the seal opening.
 - 4.1.5 Clean the pump outer surfaces prior to painting.
 - 4.1.6 If painting is required mask crank and lubricator shaft surfaces and keyways. If painting does not apply, go to Para. 4.1.8.
 - 4.1.7 Paint as specified by the customer order or as required.
 - 4.1.8 Apply a thin layer of grease to the exposed oil seal lips.
 - 4.1.9 Apply a thin layer of heavy rust preventative to the exposed crank and lubricator shaft surfaces and keyways.
 - 4.1.10 Wrap the exposed crank and lubricator shafts with waxed tape.
 - 4.1.11 Carefully wrap the following parts prior to placing them into polyurethane bags. Oil level gages, lube pressure gages, and breather caps.
 - 4.1.12 Finish box, crate and mark the parts from Para. 4.1.2 after final inspection (see Para. 4.2.2).
- 4.2 Shipping/Receiving (New Pumps Only)
- 4.2.1 All pumps and accessories (as applicable) will be final inspected by Kerr Pump personnel prior to shipping. Any witnessed or third party inspection will be signed-off by the purchaser or customer representative prior to final crating and shipment.
 - 4.2.2 Export crating will be performed by either an approved Kerr Pump source or as specified by the purchaser or customer. Any third party inspection will be coordinated with the source.
 - 4.2.3 Upon receipt of the shipment, the purchaser or customer is responsible for inspection and repair of damaged coatings at the expense of the shipper.

5.0 WARRANTY/START-UP

- 5.1 Pumps prepared per the above procedure qualify for the "Standard Terms & Conditions" in force on the date of shipment.
- 5.2 If the pump storage period is less than 6 months, follow the Short Term Pump Preparation Procedure.
- 5.3 Prior to start-up:
 - 5.3.1 Remove all storage caps, plugs, and covers.
 - 5.3.2 Replace any damaged or cracked O-rings or gaskets.
 - 5.3.3 Inspect power end shaft oil seals and replace if cracked, split or damaged.
 - 5.3.2 Install crankcase drain plug, lubrication level site glass and breather cap.
 - 5.3.3 Install, if applicable, any oil pressure and/or temperature gage.
 - 5.3.4 Check the connection of the plunger and pony rod to the crosshead prior to, and after, initial run-in of the pump.
 - 5.3.5 Fill the crankcase to the proper level with the specified lubricant.



TECHNICAL DATA SHEET

T.D.S. NO. 4.3

Page 1 OF 2

Date 03-10-06

PCN: _____

Supercedes PCN: _____

TITLE: Long Term Storage Preparation Procedure

1.0 SCOPE

This procedure applies to Kerr Pumps ONLY. Storage procedures for any other unit components or accessories (gear reducers, engines, etc.) are to be prepared to the specific manufacture's recommendations.

1.1 Long-term storage is defined as storage and/or transient time exceeding six (6) months in an environment defined in Paragraph 2. If storage for less than six months is expected, the Short Term Pump Storage Preparation Procedure should be followed.

1.2 Kerr Pumps will only prepared for short term storage if so specified in the purchaser or customer order control document.

2.0 STORAGE ENVIRONMENT

A minimal environmental condition, to be met by the customer or purchaser, is a closed shelter to eliminate effects of sun, wind, sand or other debris. Large temperature and humidity changes should be avoided to prevent preventative deterioration or contamination by moisture.

3.0 RUST PREVENTATIVE PRODUCT

3.1 **The recommended rust preservative should protect the internal power end parts from corrosion due to atmospheric moisture, and may be left in the pump when filled with appropriate lubricant and placed into service. The elevated temperature of service will cause rapid depletion of the preventative protection.**

3.2 The following rust preventative products or their equivalents are recommended for use in Kerr Pumps and usually available in 5 gallon, 55 gallon containers:

CITGO: RUST-O-LINE OIL 10

SHELL: ENSIS OIL N

4.0 PROCEDURE

4.1 Preparation from; factory testing, inventory, or a distributor rebuild facility.

4.1.1 Drain any oil that may be in the power end and then fill the complete power end cavity with the specified rust preventative. After 15 to 20 minutes, drain the rust preventative back into its storage drum for future use.

4.1.2 Remove all plungers, pony rods (if applicable), baffle discs, packing and junk rings.

4.1.3 Remove and clean oil level gages, pressure gages and breather caps. Replace with pipe plugs in threaded openings.



TECHNICAL DATA SHEET

T.D.S. NO. 4.3

Page 2 OF 2

Date 03-10-06

PCN: _____

Supersedes PCN: _____

- 4.1.4 All breathers shall be replaced with airtight seals, plugs or gasketed plates. No venting is recommended as it may allow moist air in.
 - 4.1.5 Remove the wiper box seals and cap/plug the seal opening.
 - 4.1.6 Clean the pump outer surfaces prior to painting.
 - 4.1.7 If painting is required mask crank and lubricator shaft surfaces and keyways. If painting does not apply, go to Para. 4.1.9.
 - 4.1.8 Paint as specified by the customer order or as required.
 - 4.1.9 Apply a thin layer of grease to the exposed oil seal lips.
 - 4.1.10 Apply a thin layer of heavy rust preventative to the exposed crank and lubricator shaft surfaces and keyways.
 - 4.1.11 Wrap the exposed crank and lubricator shafts with waxed tape.
 - 4.1.12 Carefully wrap the following parts prior to placing them into polyurethane bags. Oil level gages, lube pressure gages, and breather caps.
 - 4.1.13 Finish box, crate and mark the parts from Para. 4.1.10 after final inspection (see Para. 4.2.2).
- 4.2 Shipping/Receiving (New Pumps Only)
- 4.2.1 All pumps and accessories (as applicable) will be final inspected by Kerr Pump personnel prior to shipping. Any witnessed or third party inspection will be signed-off by the purchaser or customer representative prior to final crating and shipment.
 - 4.2.2 Export crating will be performed by either an approved Kerr Pump source or as specified by the purchaser or customer. Any third party inspection will be coordinated with the source.
 - 4.2.3 Upon receipt of the shipment, the purchaser or customer is responsible for inspection and repair of damaged coatings at the expense of the shipper.

5.0 WARRANTY / START-UP

- 5.1 Pumps prepared per the above procedure qualify for the "Standard Terms & Conditions" in force on the date of shipment.
- 5.2 If the pump storage period will exceed 6 months, follow the Long-Term Pump Preparation Procedure.
- 5.3 Prior to start-up:
 - 5.3.1 Remove all storage caps, plugs, and covers.
 - 5.3.2 Install the packing, junk rings, plungers, pony rods (if applicable), baffle discs, and wiper box seals. Replace any damaged or cracked O-rings or gaskets.
 - 5.3.3 Inspect power end shaft oil seals and replace if cracked, split or damaged.
 - 5.3.2 Install crankcase drain plug, lubrication level site glass and breather cap.
 - 5.3.3 Install, if applicable, any oil pressure and/or temperature gage.
 - 5.3.4 Check the connection of the plunger and pony rod to the crosshead prior to, and after, initial run-in of the pump.
 - 5.3.5 Fill the crankcase to the proper level with the specified lubricant.

Kerr Pump Maintenance Schedule for Piston Type (PT) Pumps	Daily or 8 Hrs	Weekly or 40 Hrs	Monthly or 200 Hrs	Quarterly or 500 Hrs	Semi-Annual or 1000 Hrs	Yearly or 2000 Hrs
Check Oil Level in Pump	Visual Inspection	Visual Inspection	Service			
Check Oil Level in Planetary Gear	Visual Inspection	Visual Inspection	Service			
Check for Water or Bentonite in Gear Box	Visual Inspection	Visual Inspection	Visual Inspection	Visual Inspection	Visual Inspection	Visual Inspection
Check Piston Chamber for Leaking Pistons	Visual Inspection	Visual Inspection	Visual Inspection	Visual Inspection	Visual Inspection	Visual Inspection
Check Recovery Tank for Bentonite	Visual Inspection	Visual Inspection	Service			
Check Piston Cooling Pump for Proper Operation	Visual Inspection	Visual Inspection	Visual Inspection	Visual Inspection	Visual Inspection	Visual Inspection
Flush Fluid End	Service	Service	Service	Service	Service	Service
Check Pony Rod Seals	Visual Inspection	Visual Inspection	Visual Inspection	Visual Inspection	Service	
Check and Replace if Necessary Piston Cups		Visual Inspection	Visual Inspection	Visual Inspection	Service	
Check and Replace if Necessary Valve Inserts		Visual Inspection	Visual Inspection	Visual Inspection	Service	
Check and Replace if Necessary Valves and Seats		Visual Inspection	Visual Inspection	Visual Inspection	Service	
Check and Replace if Necessary Liners		Visual Inspection	Visual Inspection	Visual Inspection	Service	
Check Rod Bearings			Visual Inspection	Visual Inspection	Visual Inspection	Service
Check Pony Rods	Visual Inspection	Visual Inspection	Visual Inspection	Visual Inspection	Visual Inspection	Visual Inspection
Check Belts	Visual Inspection	Visual Inspection	Visual Inspection	Visual Inspection	Visual Inspection	Service

Wing Guided Valve Changing Instructions



1.) Remove the nuts/cap screws from the top cover.

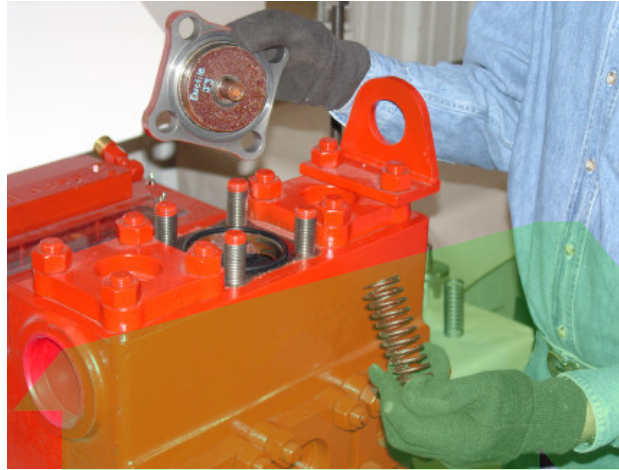

2.A) Remove the top cover and discharge spring.
2.B) Inspect the o-ring for damage.

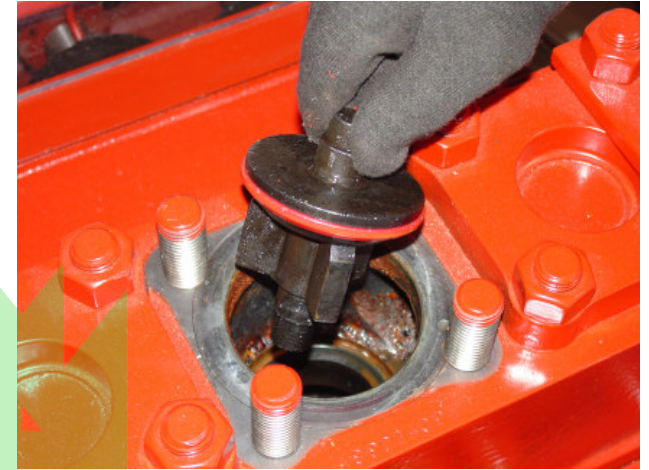

3.) Remove the discharge valve.

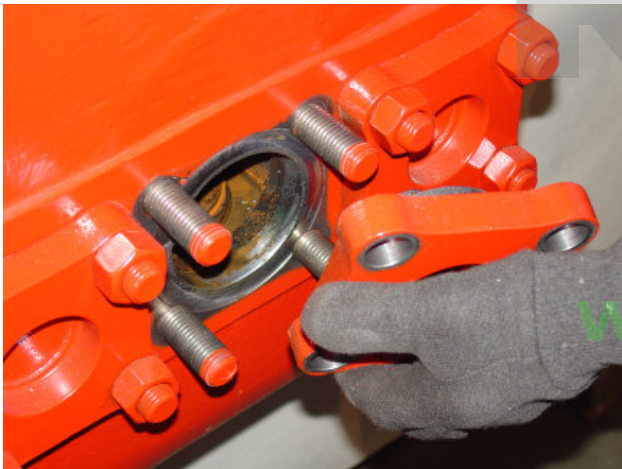

4.A) Remove the end cover cap and suction spring.
4.B) Inspect the valve spring for damage.



5.) Remove the suction valve.



6.) Insert the tri-pin puller head, all pins retracted, into the discharge seat.

Wing Guided Valve Changing Instructions (...continued)

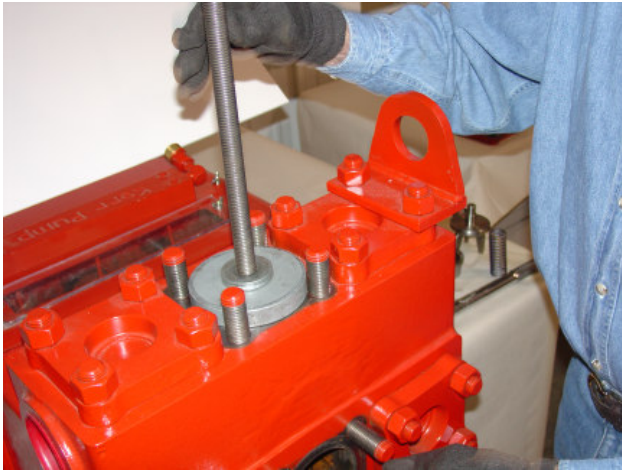

7.) Slide puller plate, spacer and washers down the puller rod.



8.) Turn the puller rod until the pins are fully extended.

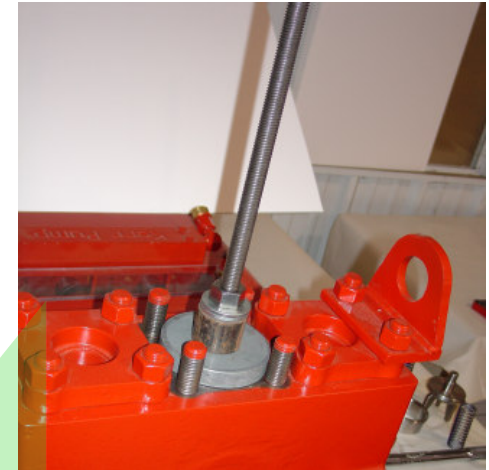

9.) Lifting the puller rod, turn the nut until firmly in contact with the washers.

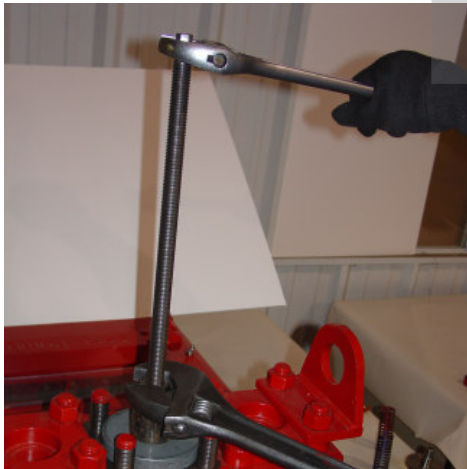

10.) Holding the top of the puller rod in place, tighten the nut until the seat releases.



11.) Remove the puller assembly with seat attached.



12.) Loosen the puller rod to retract the pins and remove the seat.

» Repeat steps 6 thru 12 for suction valve.

Wing Guided Valve Changing Instructions (...continued)



13.) Install the suction seat and valve. Drive in firmly using bar and hammer.



14.) Install the discharge seat and valve. Drive in firmly using bar and hammer.



15.) Install the suction spring.

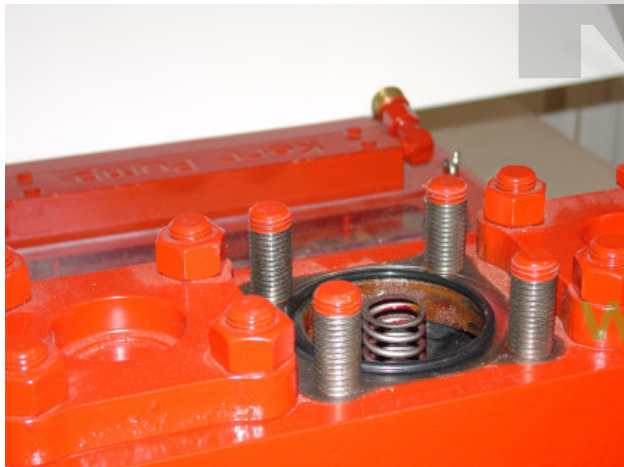

16.) Install the discharge spring.



17.) Tighten all bolts/nuts to specified torque from chart.

RHINO
SUPPLY
www.rhinosupply.nl

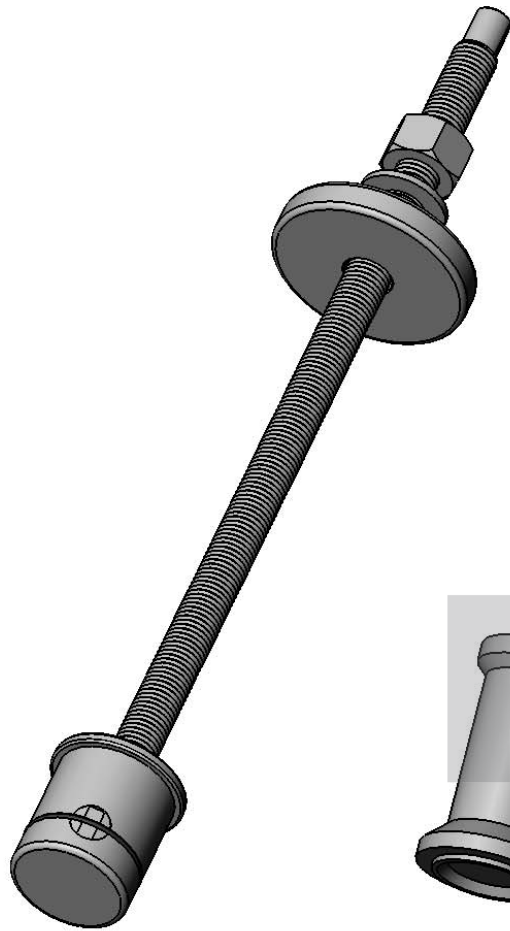

KA-68M
WING-
GUIDED
SEAT
TRI-PIN
TYPE
PULLER
ASS'Y

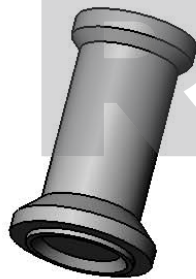

KA-29SG-3
SEAL
GUARD
WIPER
DRIVER

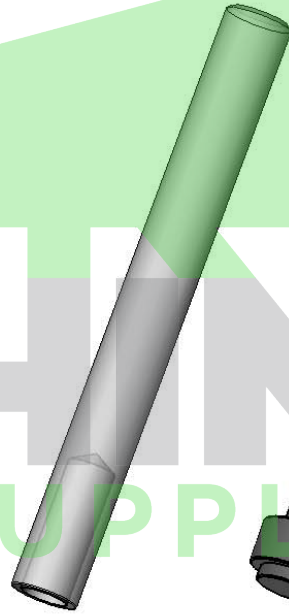

KA-306
VALVE
SEAT
SEATING
TOOL



KA-276
PONY ROD
SEAL TOOL

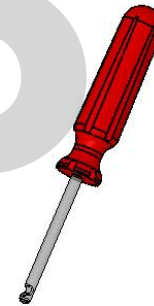

AP-77T
VALVE
INSERT
TOOL

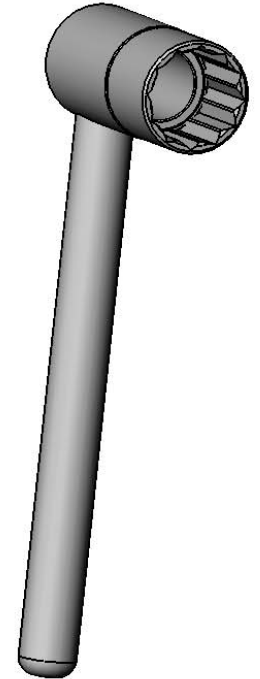

KA-277
PONY
ROD
WRENCH

SPECIAL TOOLS
FOR KA-3500PT, KT-3350PT, & KT-3400PT

How To Put Inserts In Valves Using Kerr Valve Insert Tool



1) Push Valve Insert over valve legs. Hint: (Insert will be more pliable if heated first-- warm to the touch not hot).



2) Put Tool between valve and valve insert with groove against valve.



3) Holding Valve insert down with thumb.



4) While holding valve down with thumb, rotate around valve with tool. (Similar to mounting a tire on a rim).



5) Continue rotating around valve with tool until insert is completely in groove.

CRITICAL NOTE:
MATCH GROOVE
& KEEP PIECES TOGETHER
DO NOT MIX WITH
ANOTHER KA-280-A

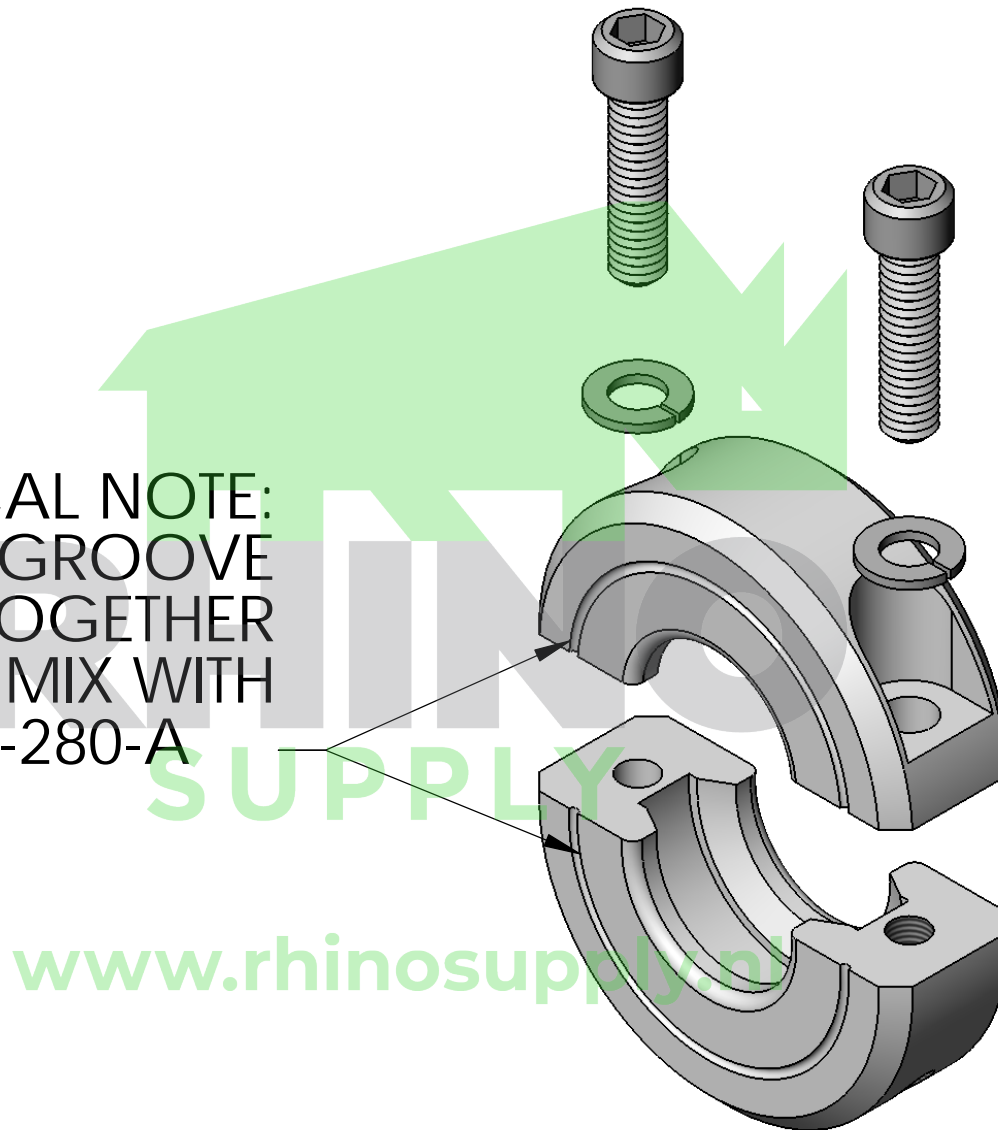

KA-KT-280-A

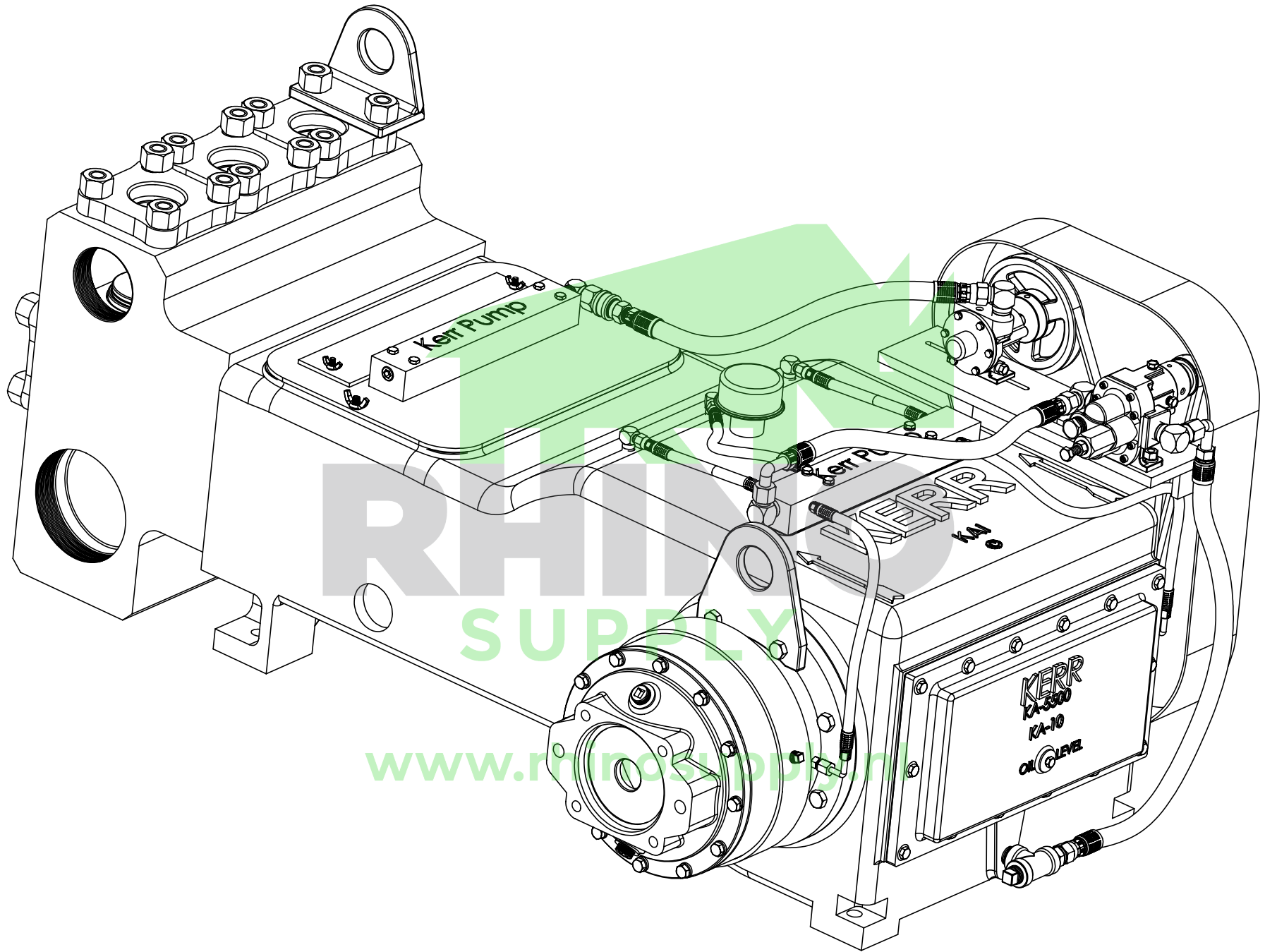

KA-3500PT

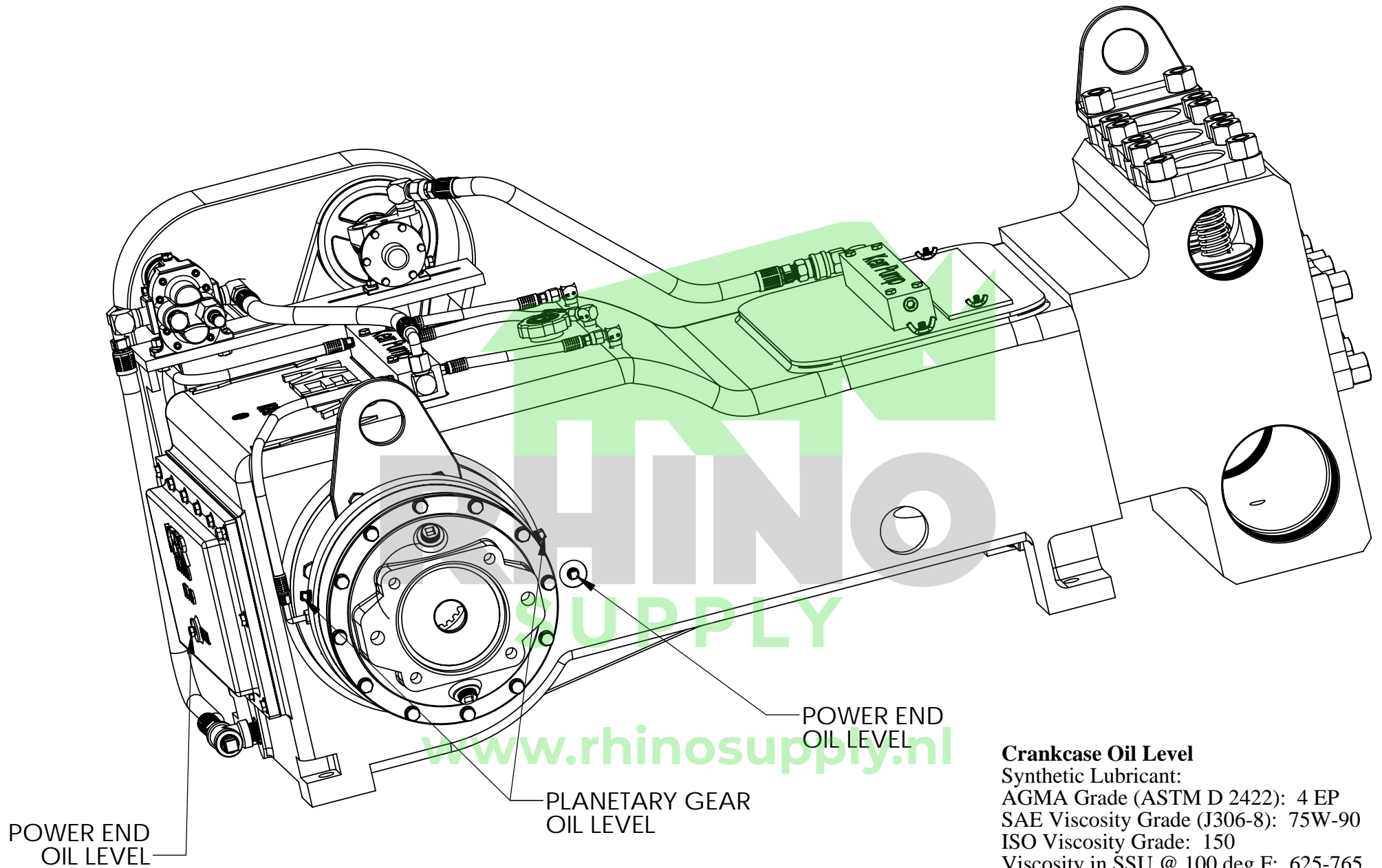

KA-3500PT OIL LEVEL ILLUSTRATION

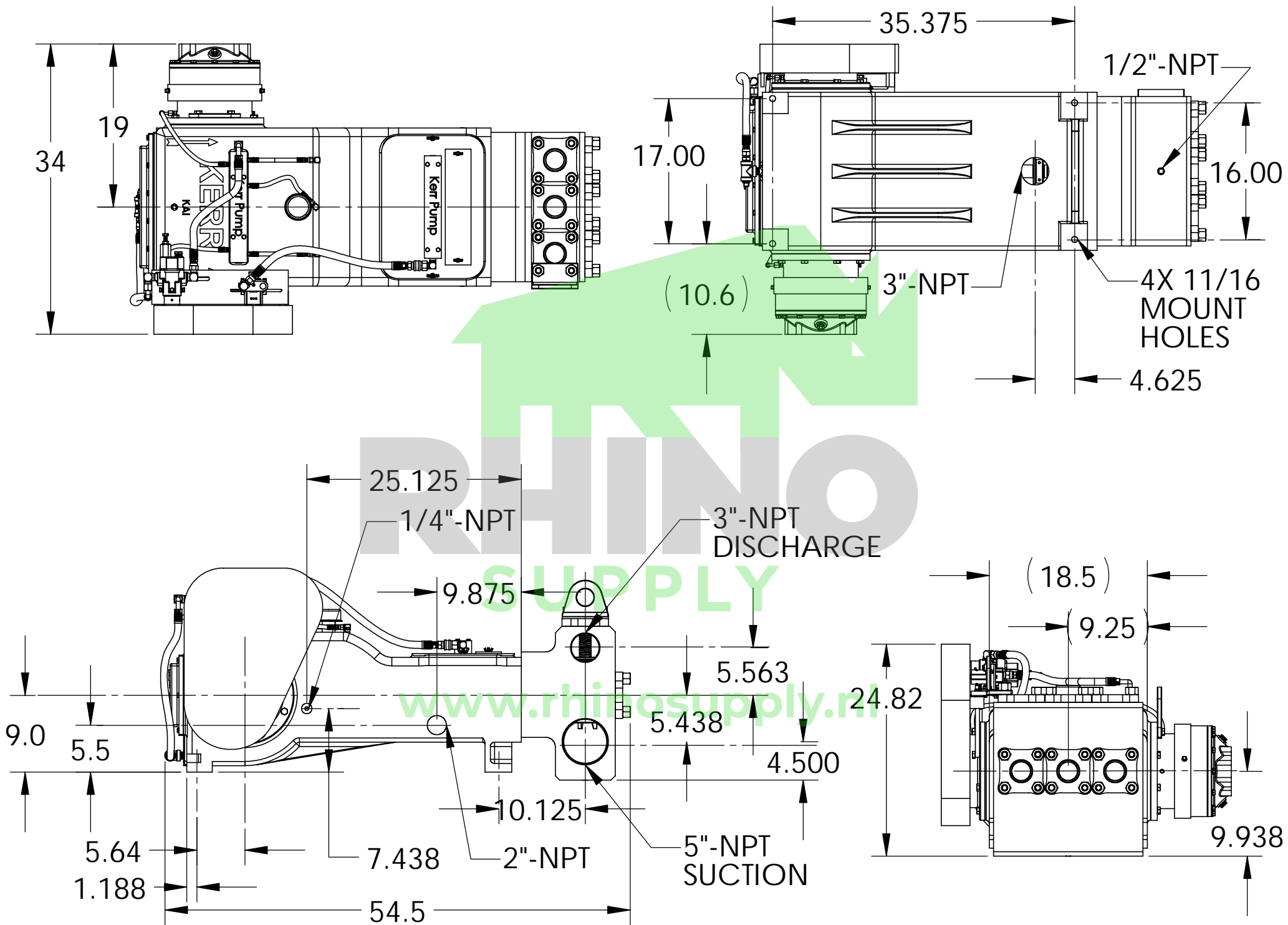

GENERAL DIMENSIONS FOR KA-3500PT

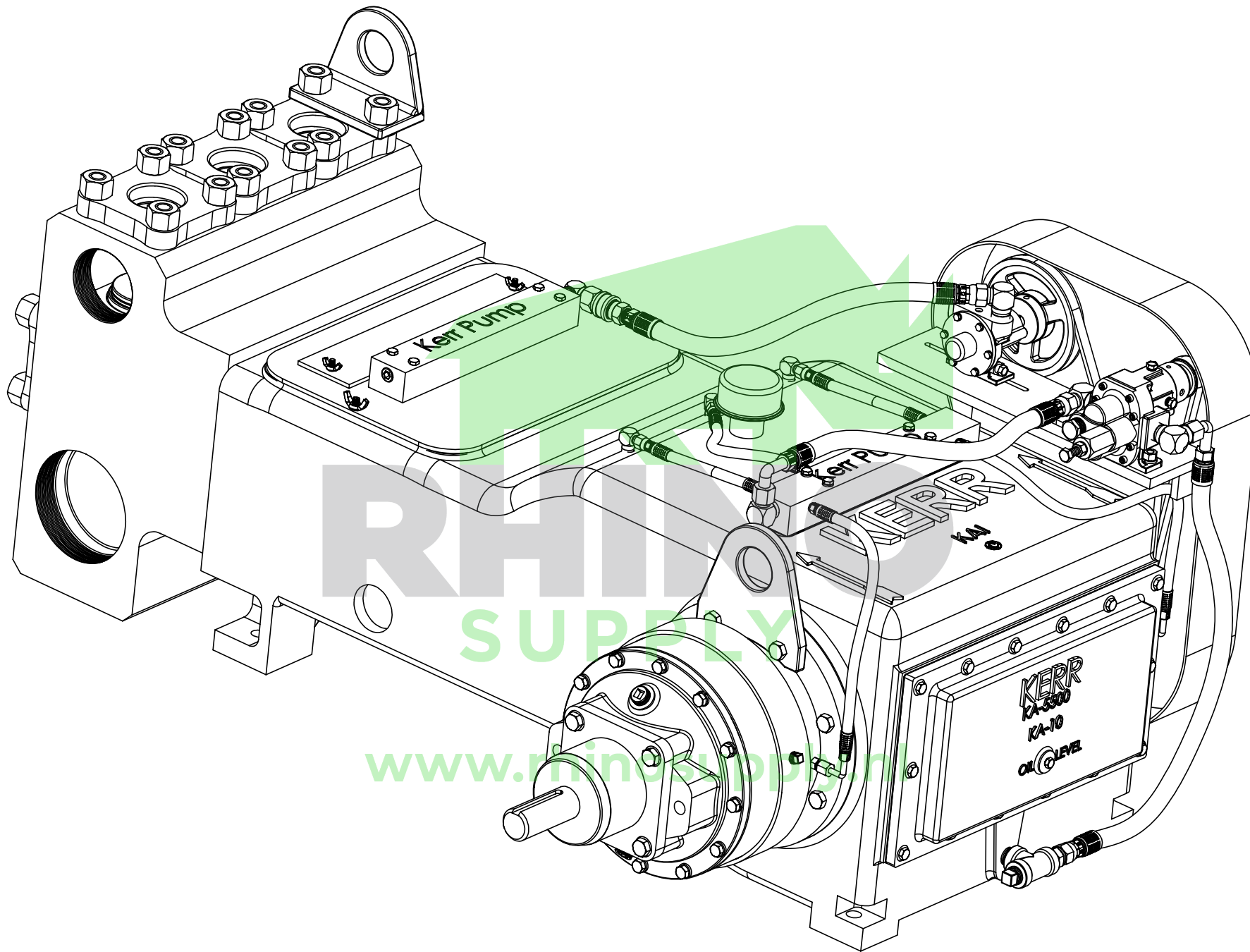

KA-3500PT WITH DRIVE ASSEMBLY

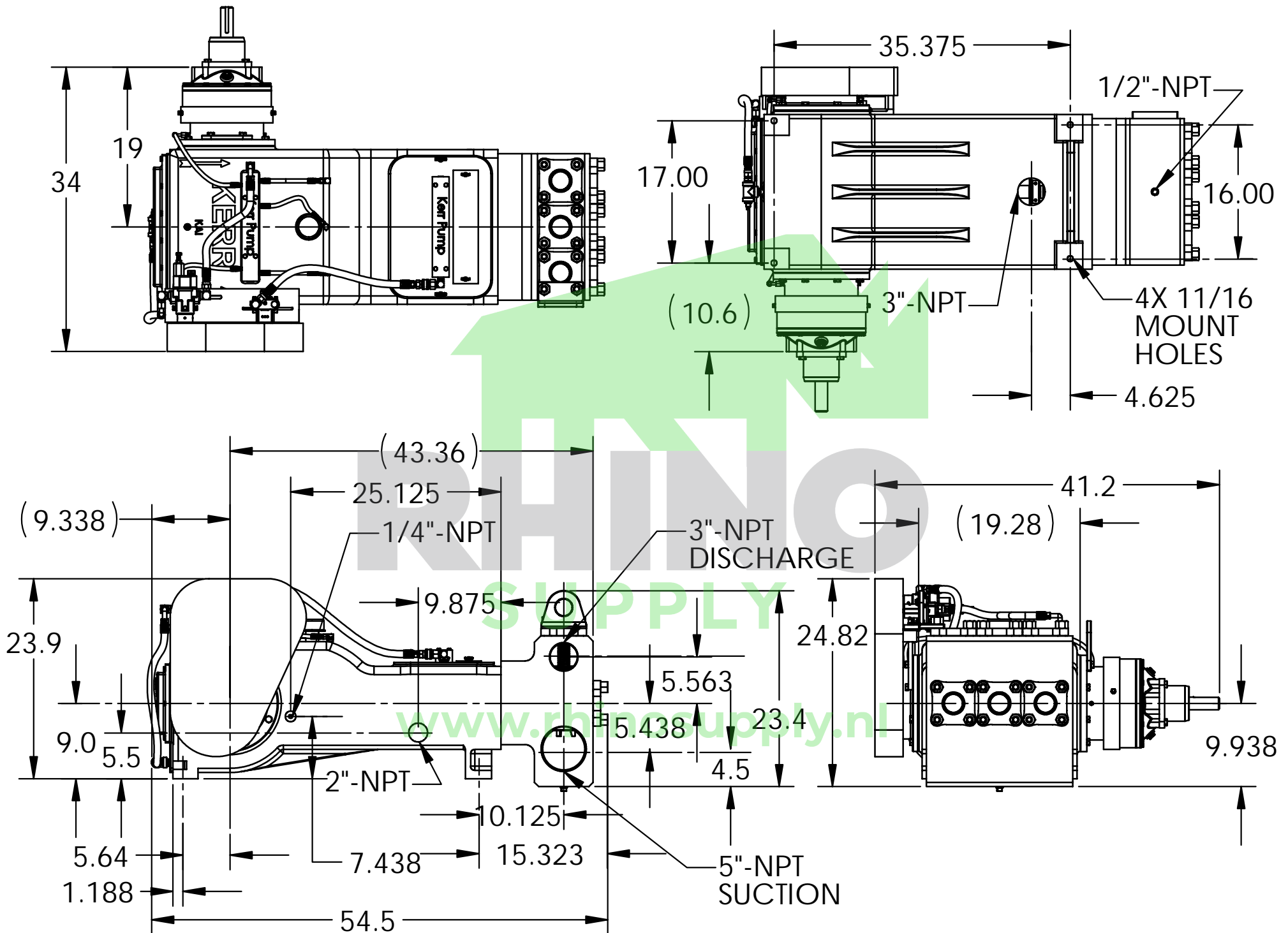

GENERAL DIMENSIONS FOR KA-3500PT WITH DRIVE ASSEMBLY

ITEM NO.	QTY.	PART NO.	DESCRIPTION
1	1	KA-33D	FLUID END, VESSEL ONLY (DUCTILE)
2	3	KA-073HT	SUCTION VALVE, HEAT TREATED, A/R WITH INSERT
3	6	KA-77	ABRASIVE RESISTANT VALVE INSERT
4	3	KA-072HT	DISCHARGE VALVE, HEAT TREATED, A/R WITH INSERT
5	3	KA-34D	TOP COVER CAP (DUCTILE)
6	3	KA-52L	VALVE SPRING (DISCHARGE) (LONG)
7	3	KA-52S	VALVE SPRING (SUCTION) (SHORT)
8	6	KA-074HT	VALVE SEAT, HEAT TREATED, A/R
9	9	KA-38	O-RING COVER CAP
10	22	KA-36	COVER CAP STUD
11	24	KA-37	COVER CAP STUD NUT
12	3	KA-35D	END COVER CAP (DUCTILE)
13	1	KA-126FE	FLUID END LIFTING EYE
14	2	KA-36B	COVER CAP BRACKET STUD
15	1	AP-71	FLUID END DRAIN PLUG

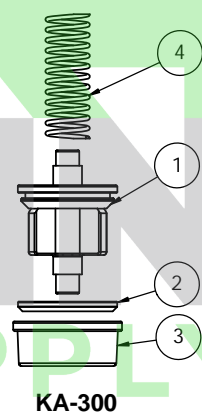
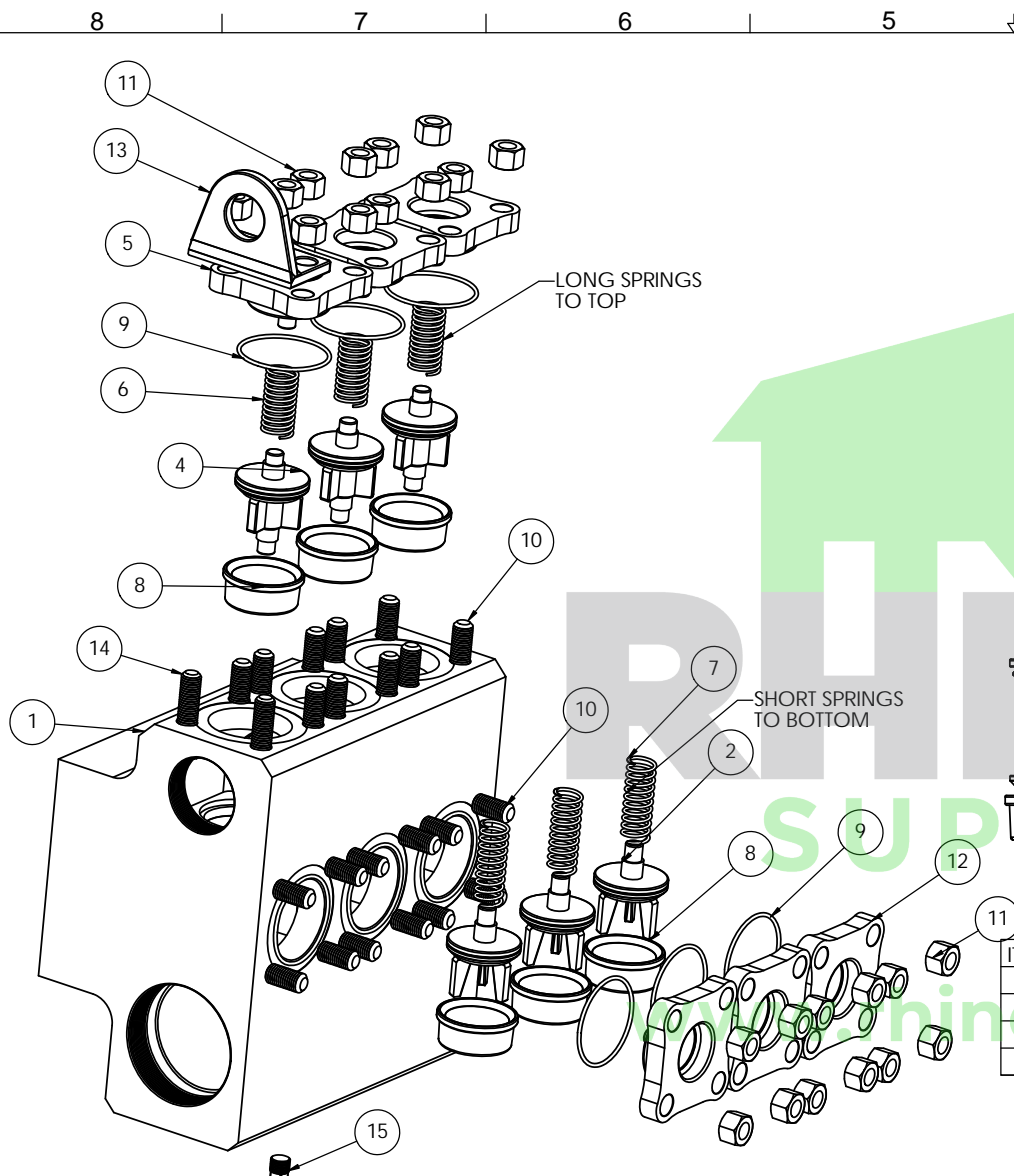

KA-300

ITEM NO.	QTY.	PART NO.	DESCRIPTION
1	1	KA-072HT	DISCHARGE VALVE, HEAT TREATED, A/R WITH INSERT
2	1	KA-77	ABRASIVE RESISTANT VALVE INSERT
3	1	KA-074HT	VALVE SEAT, HEAT TREATED, A/R
4	1	KA-52L	VALVE SPRING (DISCHARGE) (LONG)

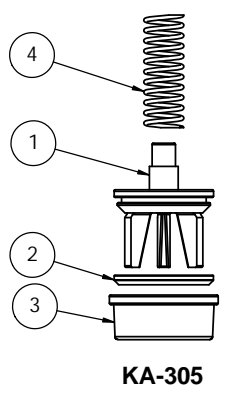

KA-305

ITEM NO.	QTY.	PART NO.	DESCRIPTION
1	1	KA-073HT	SUCTION VALVE, HEAT TREATED, A/R WITH INSERT
2	1	KA-77	ABRASIVE RESISTANT VALVE INSERT
3	1	KA-074HT	VALVE SEAT, HEAT TREATED, A/R
4	1	KA-52S	VALVE SPRING (SUCTION) (SHORT)

KERR MACHINE CO BOX 735 SULPHUR OK 73086
PHONE (580) 622-4207 FAX (580) 622-4206

WARNING: CONFIDENTIAL AND PROPRIETARY INFORMATION OF "Kerr Pumps" DO NOT DISCLOSE, COPY OR REPRODUCE ANY OR PART OF THIS PRINT WITHOUT PRIOR WRITTEN APPROVAL FROM KERR MACHINE CORPORATION.	UNLESS OTHERWISE SPECIFIED TOLERANCES MACHINE = ± .030 X = ± .010 XX = ± .005 XXX = ± .0010 ANGLES ± 1/2°	1. MATL: 2. DIMS. ARE IN INCHES 3. DIM MAY VARY ACCORDING TO CASTING 4. REMOVE ALL BURRS AND SHARP CORNERS 5. DO NOT SCALE DRAWING 6. MACHINE FINISH 63	DESIGNED BY: B MILNER 04-23-99 DRAWN BY: K LACKEY 02-11-00 REFERENCE: PUMP: KA-5500-PT THIRD ANGLE PROJECTION	Kerr Pumps TITLE: SULPHUR OK FLUID END ASSEMBLY DRAWING
	SIZE D SCALE: 3:8	DWG. NO. KA-33D-A	REV A	SHEET 1 OF 1

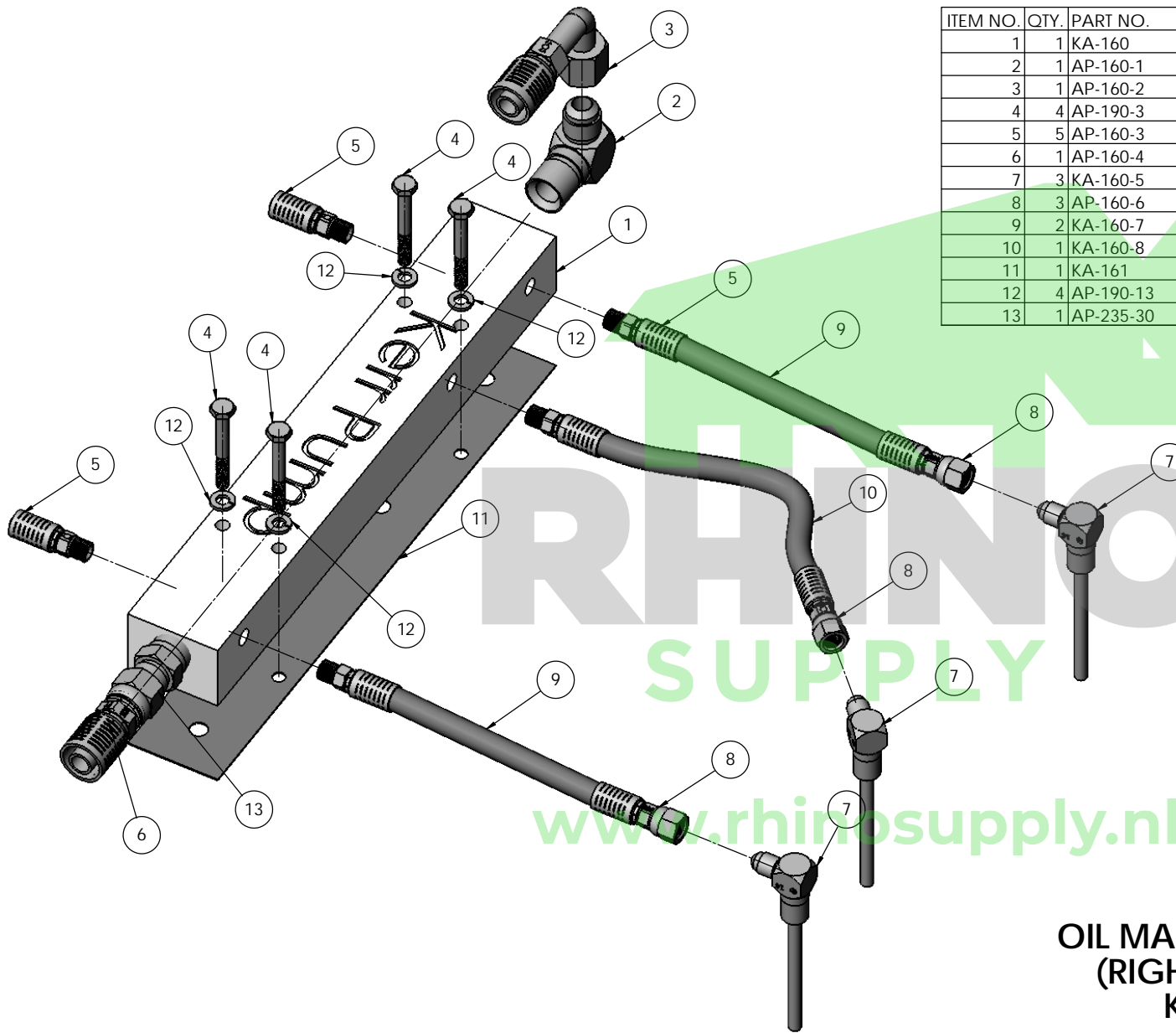

ITEM NO.	QTY.	PART NO.	DESCRIPTION
1	1	KA-160	OIL MANIFOLD
2	1	AP-160-1	JIC MALE ELBOW 1/2
3	1	AP-160-2	SAE 37 JIC FML SWIVEL 90 TUBE ELBOW 1/4 X 1/2
4	4	AP-190-3	WATER MANIFOLD / OIL MANIFOLD BOLT
5	5	AP-160-3	MALE PIPE RIGID 1/4 X 1/8
6	1	AP-160-4	1/2-NPT PIPE PLUG SOCKET TYPE INTERNAL HEX
7	3	KA-160-5	FITTING, CROSSHEAD OIL INJECTOR
8	3	AP-160-6	SAE 37 (JIC) FEMALE SWIVEL 1/4 X 1/4
9	2	KA-160-7	5 1/2" (450 DEG) SS TEFLON HOSE
10	1	KA-160-8	6 1/2" (450 DEG) SS TEFLON HOSE
11	1	KA-161	OIL MANIFOLD GASKET
12	4	AP-190-13	1/4 LOCK WASHER
13	1	AP-235-30	SAE 37 JIC FML SWIVEL 3/8 X 1/2

**OIL MANIFOLD ASSEMBLY
(RIGHT-HAND DRIVE)
KA-160RH-A**

REV B: 05-09-00 ADDED ITEMS 15 & 16;
 REV C: 01-17-07 UPDATED PART NO'S.

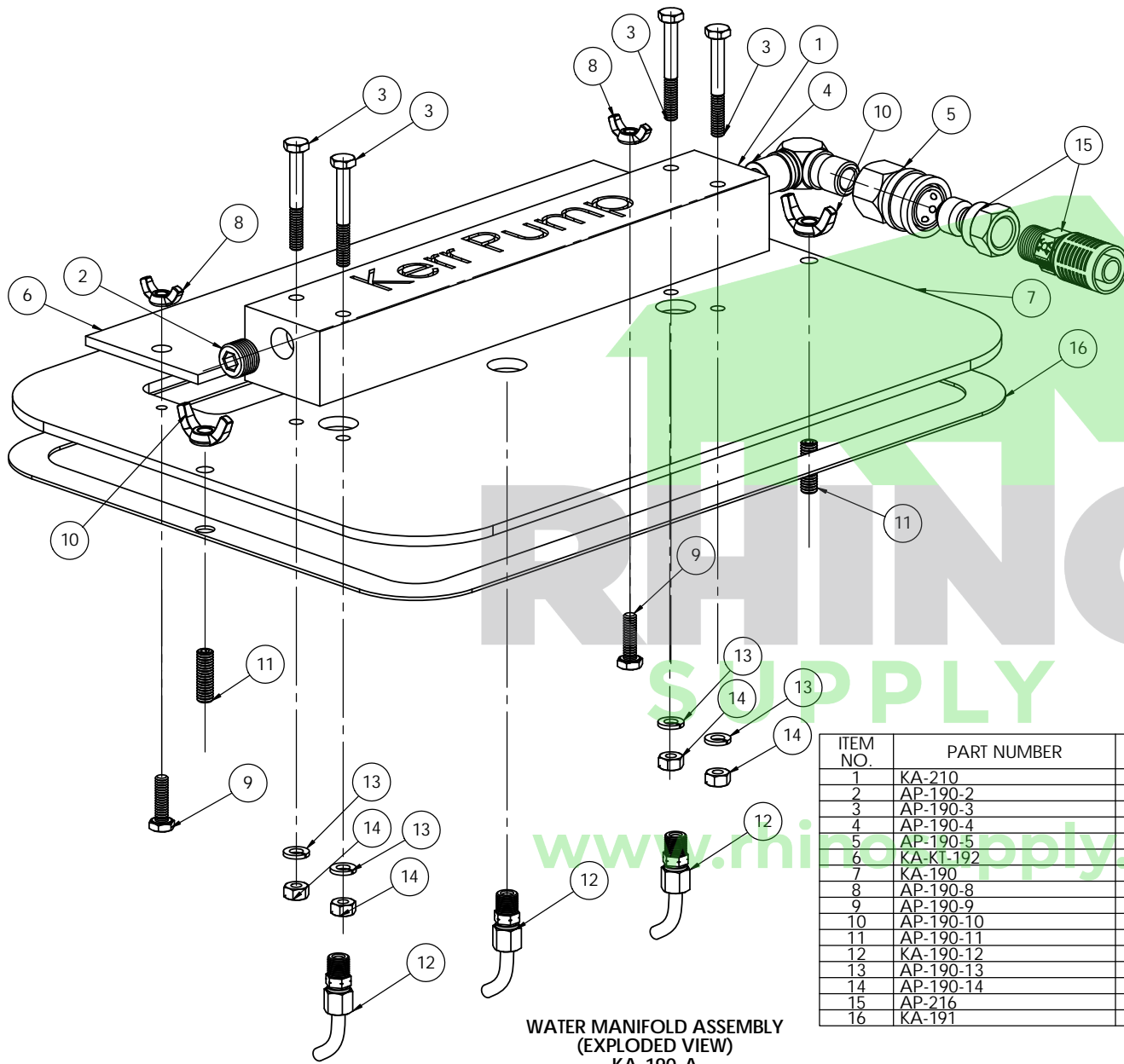

WATER MANIFOLD ASSEMBLY
 (EXPLODED VIEW)
 KA-190-A

ITEM NO.	PART NUMBER	DESCRIPTION	QTY.
1	KA-210	WATER MANIFOLD	1
2	AP-190-2	WATER MANIFOLD PLUG	1
3	AP-190-3	WATER MANIFOLD / OIL MANIFOLD BOLT	4
4	AP-190-4	WATER MANIFOLD 90 DEGREE FITTING	1
5	AP-190-5	3/8 QUICK COUPLING	1
6	KA-KT-192	PISTON CHAMBER COVER SIGHT GLASS	1
7	KA-190	PISTON CHAMBER COVER	1
8	AP-190-8	PISTON CHAMBER COVER INSPECTION GLASS WING NUT	2
9	AP-190-9	PISTON CHAMBER COVER INSPECTION GLASS CAPSCREW	2
10	AP-190-10	PISTON CHAMBER COVER WING NUT	2
11	AP-190-11	PISTON CHAMBER COVER CAPSCREW	2
12	KA-190-12	FITTING WATER JET	3
13	AP-190-13	1/4 LOCK WASHER	4
14	AP-190-14	1/4-20UNC NUT	4
15	AP-216	3/8" QUICK CONNECT	1
16	KA-191	PISTON CHAMBER COVER GASKET	1

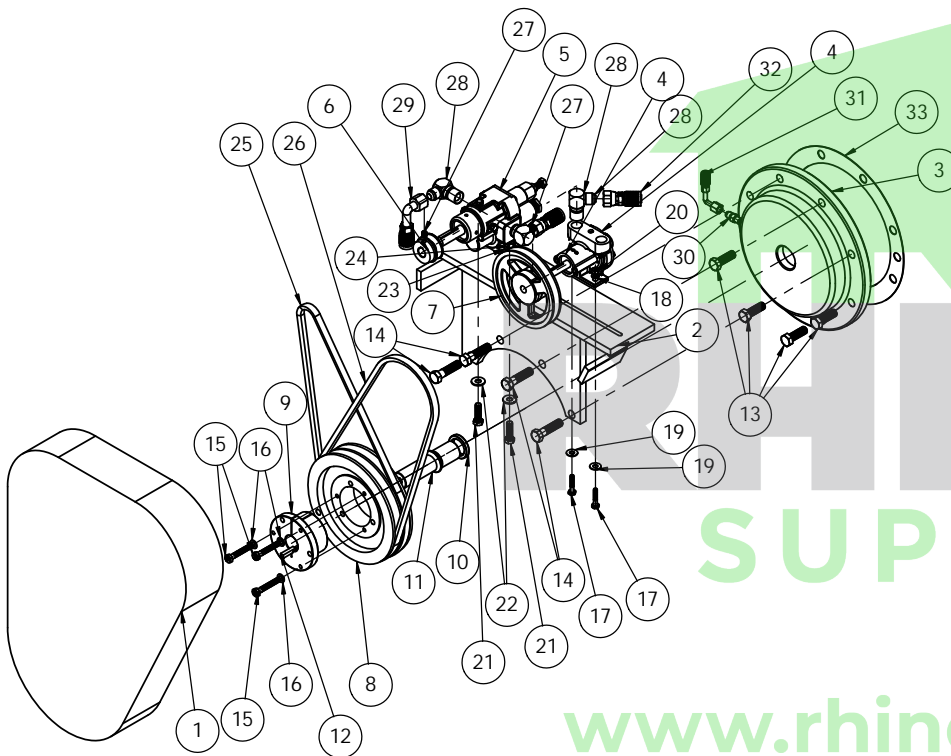

ITEM NO.	QTY.	PART NO.	DESCRIPTION
1	1	KA-235	BELT GUARD, PUMP DRIVE
2	1	KA-140	OIL AND WATER PUMP BRACKET
3	1	KA-130	BEARING HOUSING, EXTENSION SHAFT
4	1	AP-195	WATER PUMP, BRONZE
5	1	AP-145	OIL PUMP, 1/2" CAST IRON
6	1	AP-150	SHEAVE, OIL PUMP
7	1	AP-200-320	SHEAVE, WATER PUMP
8	1	AP-230	SHEAVE, CRANKSHAFT DRIVE TO PUMPS
9	1	AP-230-9	SHEAVE BUSHING 1-1/8"
10	1	AP-135	OIL SEAL, BEARING HOUSING EXTENSION SHAFT
11	1	AP-132	AUXILIARY SHAFT-SUPPLIED WITH KA-KP-KT-120
12	1	AP-130-9-1	KEY- SUPPLIED WITH KA-KP-KT-230-9
13	4	KA-6	BEARING HOUSING CAPSCREW (1 1/2)
14	4	KA-6B	BEARING HOUSING CAPSCREWS (2")
15	3	KA-230-15	BOLT SUPPLIED WITH AP-230-9
16	3	KA-230-16	WASHER SUPPLIED WITH AP-230-9
17	2	AP-235-17	1/4-20UNC X 1 1/4 CAPSCREW
18	2	AP-190-13	1/4 LOCK WASHER
19	2	AP-235-19	1/4 WASHER
20	2	AP-190-14	1/4-20UNC NUT
21	2	AP-235-21	3/8-16UNC X 1 1/4
22	2	AP-235-22	3/8 WASHER
23	2	AP-235-23	3/8 LOCK WASHER
24	2	AP-235-24	3/8-16-UNC HEX HEAD NUT
25	1	KA-155	BELT, OIL PUMP
26	1	KA-205-039	BELT, WATER PUMP
27	2	AP-235-27	3/8-16UNC X 3/8 SETSCREW
28	3	AP-160-1	JIC MALE ELBOW 1/2
29	1	AP-160-2	SAE 37 JIC FML SWIVEL 90 TUBE ELBOW 1/4 X 1/2
30	1	AP-235-31	SAE JIC MALE CONNECTOR 1/4 X 1/8
31	1	AP-235-32	SAE 37 JIC FML SWIVEL 90 DEG TUBE ELBOW 1/4 X 1/4
32	2	AP-235-30	SAE 37 JIC FML SWIVEL 3/8 X 1/2
33	1	KA-7	BEARING HOUSING GASKET

PUMP DRIVE ASSEMBLY
KA-235-A

ITEM NO.	QTY.	PART NO.	DESCRIPTION
1	1	KA-285-350HTC	LINER, 3 1/2" HEAT TREATED
2	1	KA-275	PONY ROD, PISTON PUMP TYPE
3	1	KA-265	PISTON EXTENSION ROD
4	1	KA-KT-270	PISTON EXTENSION ROD LOCK NUT
5	1	KA-290-400	LINER RETAINER 4"
6	1	KA-245-350	PISTON COMPLETE 3 1/2"
7	1	KA-280	CLAMP, PONY ROD TO PISTON ROD
8	1	KA-295	LINER GASKET
9	1	KA-32PT	PONY ROD SPLASH GUARD

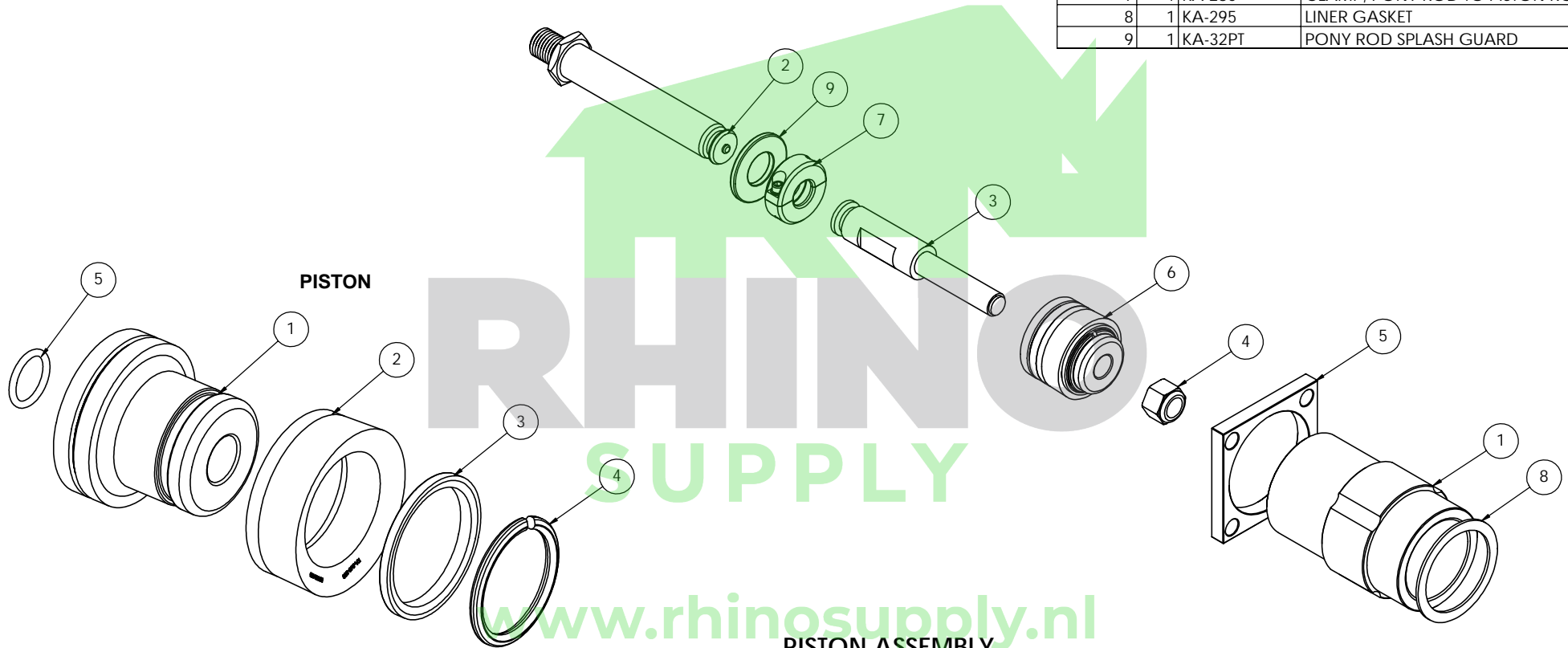

PISTON

PISTON ASSEMBLY
DRAWING

ITEM NO.	QTY.	PART NO.	DESCRIPTION
1	1	KA-250-350	PISTON, BODY ONLY, 3 1/2"
2	1	KA-263-350	PISTON CUP
3	1	KA-261-350	PISTON CUP RETAINER PLATE
4	1	KA-262-350	PISTON CUP SNAP RING
5	1	KA--246	PISTON O'RING

STUD TORQUE SEQUENCE

STUD REQUIREMENTS:

- 10 EA KA-59- FLUID END/LINER RETAINER STUDS
- 6 EA KA-59T- FLUID END/LINER RETAINER LINEUP STUDS
- 6 EA KA-59SC FLUID END/CASE CAPSCREWS

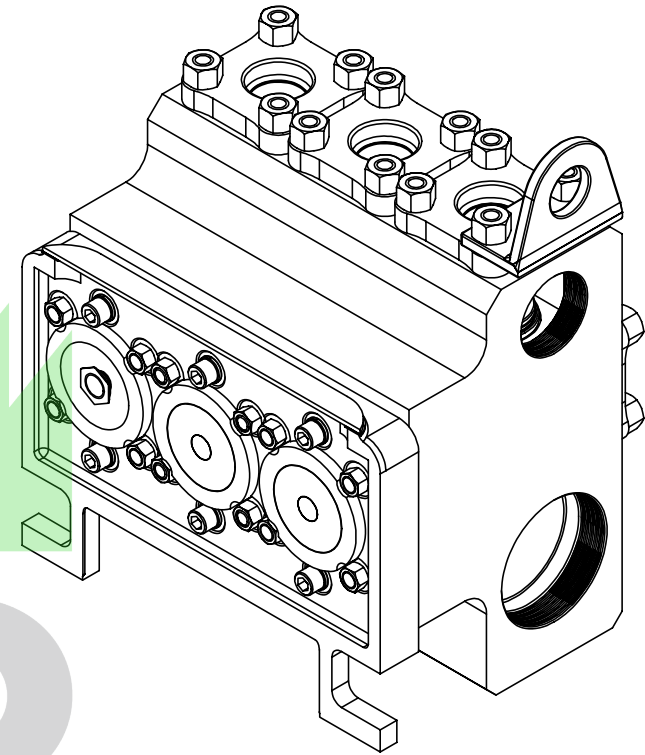
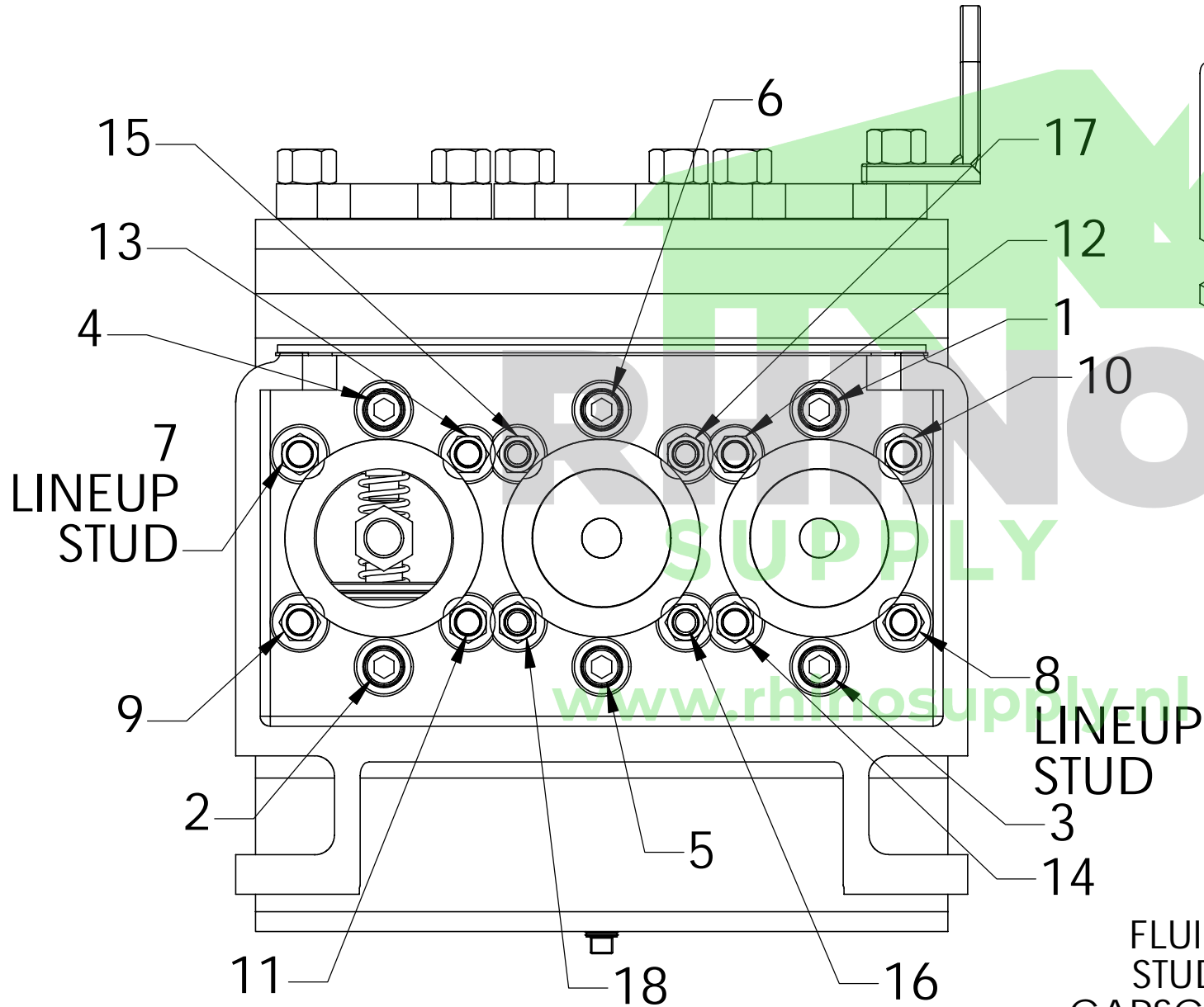

KA-3500PT
FLUID END TO POWER FRAME
STUD TORQUE SPEC 130 FT LB
CAPSCREW TORQUE SPEC 200 FT LB

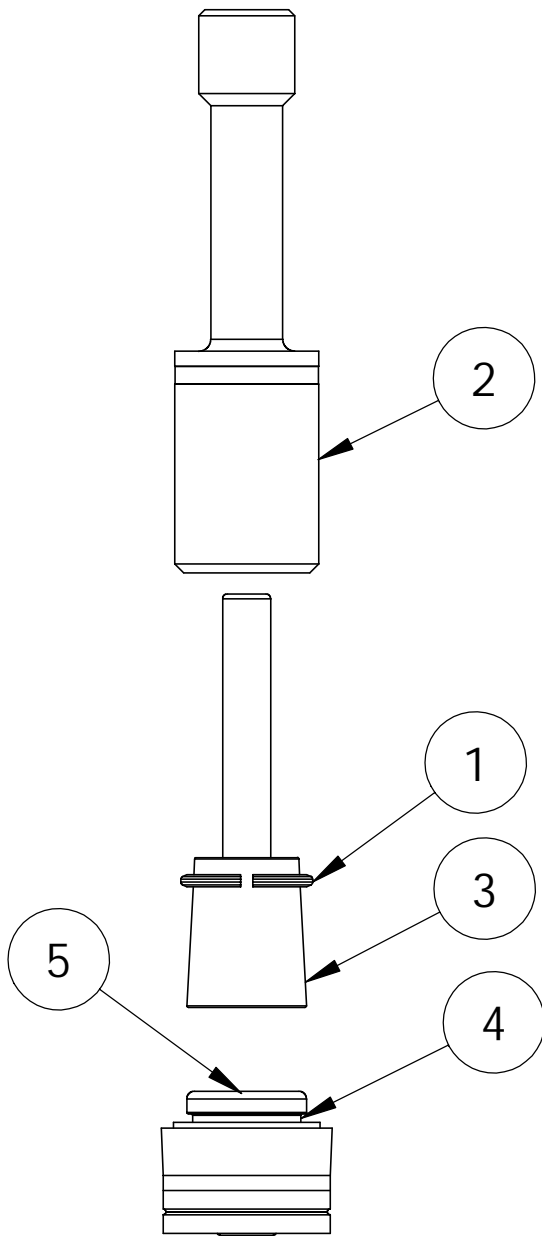

HAMMER NOT INCLUDED
WITH INSTALLATION TOOL

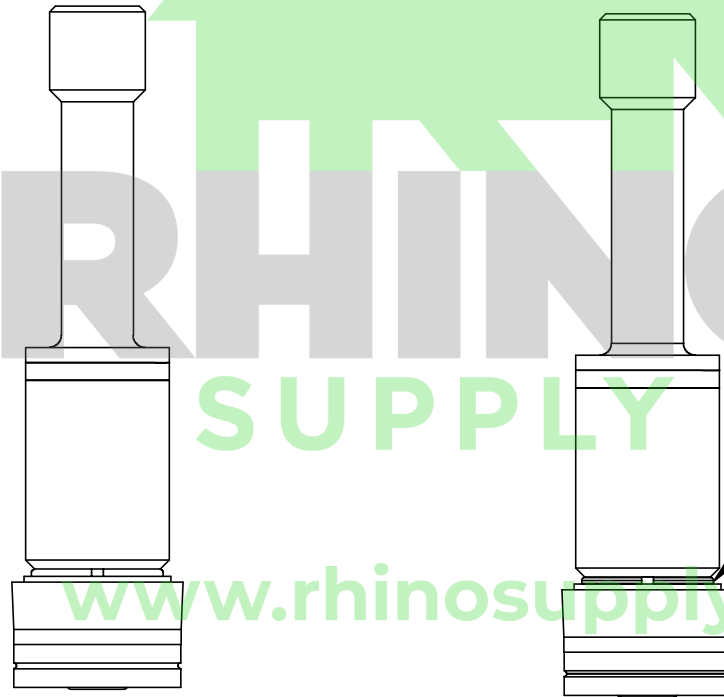
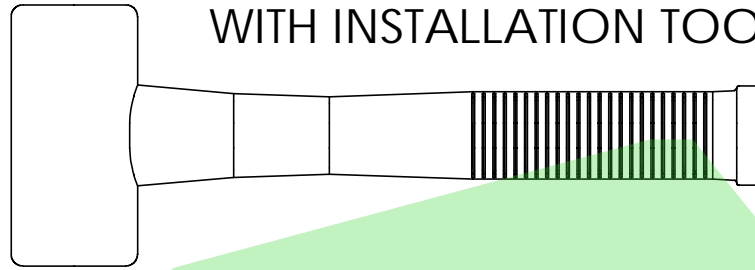

MAKE SURE
SNAP RING
SNAPS IN
GROOVE

PLACE TAPERED PLUG (3)
ON PISTON HEAD (5). SLIDE
SNAP RING (2) ONTO TOOL
TAPERED PLUG. USE SNAP
RING TOOL BODY (1) TO SEAT
SNAP RING IN PISTON HEAD
GROOVE (4).

**KA-248
PISTON SNAP RING
INSTALLATION TOOL**

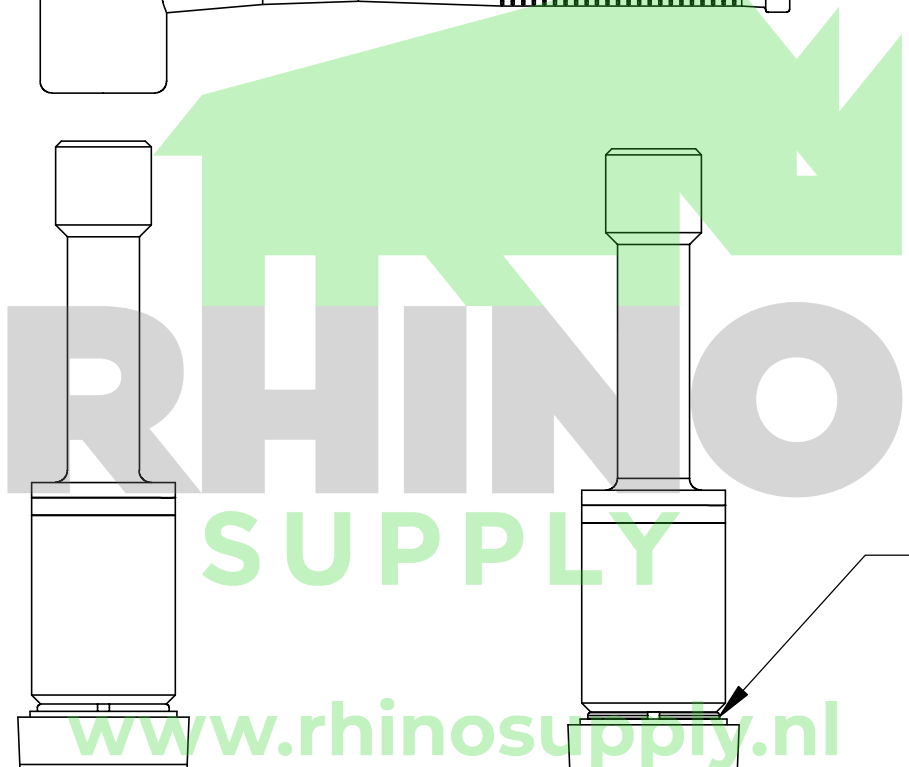

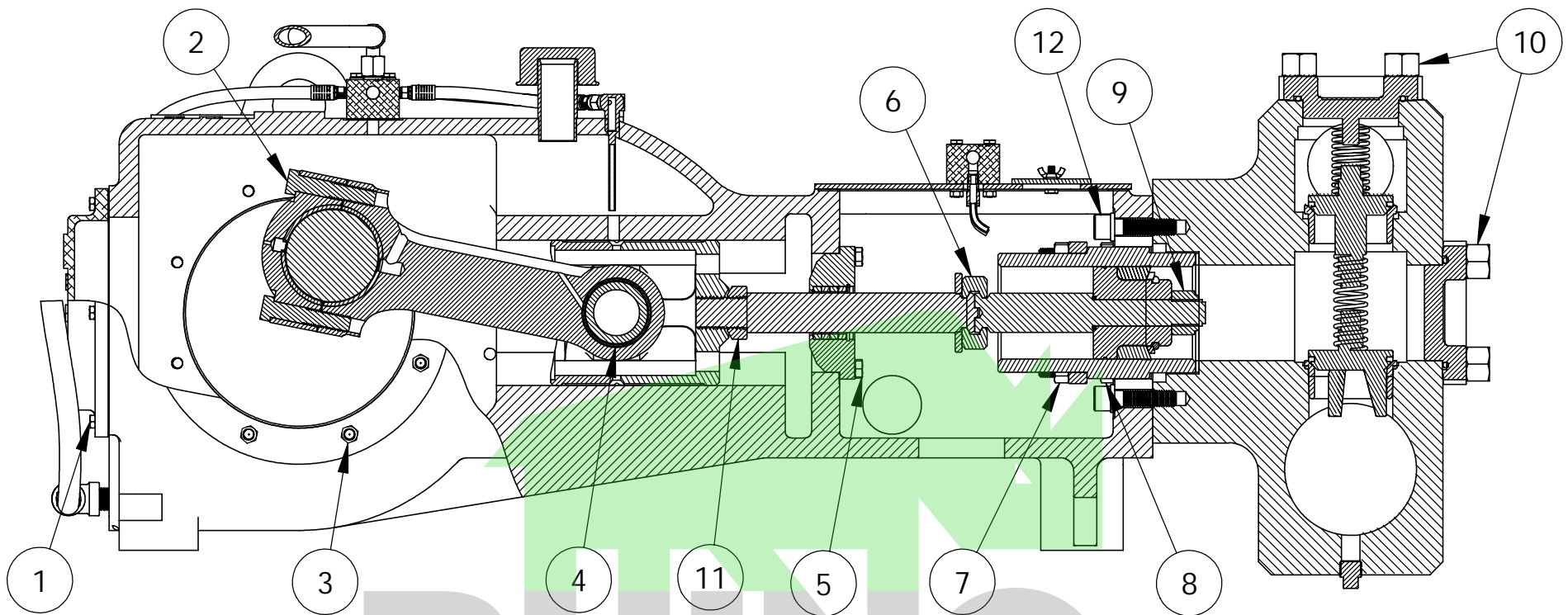

TORQUE SPECIFICATIONS

REFERENCE	DESCRIPTION	TORQUE
1	PAN COVER CAPSCREW	21 ft-lb (28 Nm)
2	CONNECTING ROD CAPSCREW	160 ft-lb (217 Nm)
3	BEARING HOUSING CAPSCREW	75 ft-lb (102 Nm)
4	WRIST PIN SET SCREW AND JAM NUT	30 ft-lb (41 Nm)
5	PONY ROD PACKING GLAND CAPSCREW	50 ft-lb (68 Nm)
6	CLAMP SOCKET HEAD CAPSCREW	20 ft-lb (27 Nm)
7	PISTON LINER RETAINER STUD NUT	110 ft-lb (149 Nm)
8	FLUID END STUD NUT	130 ft-lb (176 Nm)
9	PISTON EXTENSION ROD SELF-LOCKING NUT	500 ft-lb (678 Nm)
10	COVER CAP STUD NUT	200 ft-lb (271 Nm)
11	PONY ROD	1000 ft-lb (1356 Nm)
12	CAPSCREW FLUID END/CASE	200 ft-lb (271 Nm)

NOTE: WHEN USING LUBRICANTS, REDUCE TORQUE AS FOLLOWS:

LUBRICANT	PERCENTAGE OF TORQUE REDUCTION REQUIRED
WHITE LEAD	REDUCE TORQUE 25%
GRAPHITE	REDUCE TORQUE 30%
OIL	REDUCE TORQUE 40%
GREASE	REDUCE TORQUE 40%
ANTI - SEIZE COMPOUND	REDUCE TORQUE 45%

WHEN ADJUSTING THE ENDPLAY OF THE TAPERED ROLLER BEARINGS USED ON THE CRANKSHAFT, DIAL INDICATORS AND SHIMS MUST BE PROPERLY USED. INCORRECT BEARING ADJUSTMENT MAY RESULT IN EXCESSIVE NOISE, TEMPERATURE, AND REDUCED BEARING LIFE. Kerr Pumps RECOMMENDS BETWEEN .000" - .005" OF INTERNAL AXIAL CLEARANCE (END PLAY) WHEN ASSEMBLED. FINAL ADJUSTMENT MUST BE MADE USING A DIAL INDICATOR.

INSURE THE CONNECTING RODS ARE DISCONNECTED TO ALLOW FREE CRANKSHAFT MOTION.

KA-3500PT SPECIFICATIONS

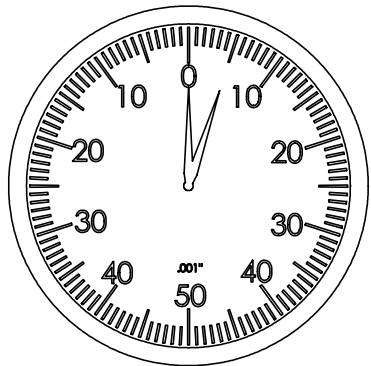

.000" - .005"
SHAFT END PLAY

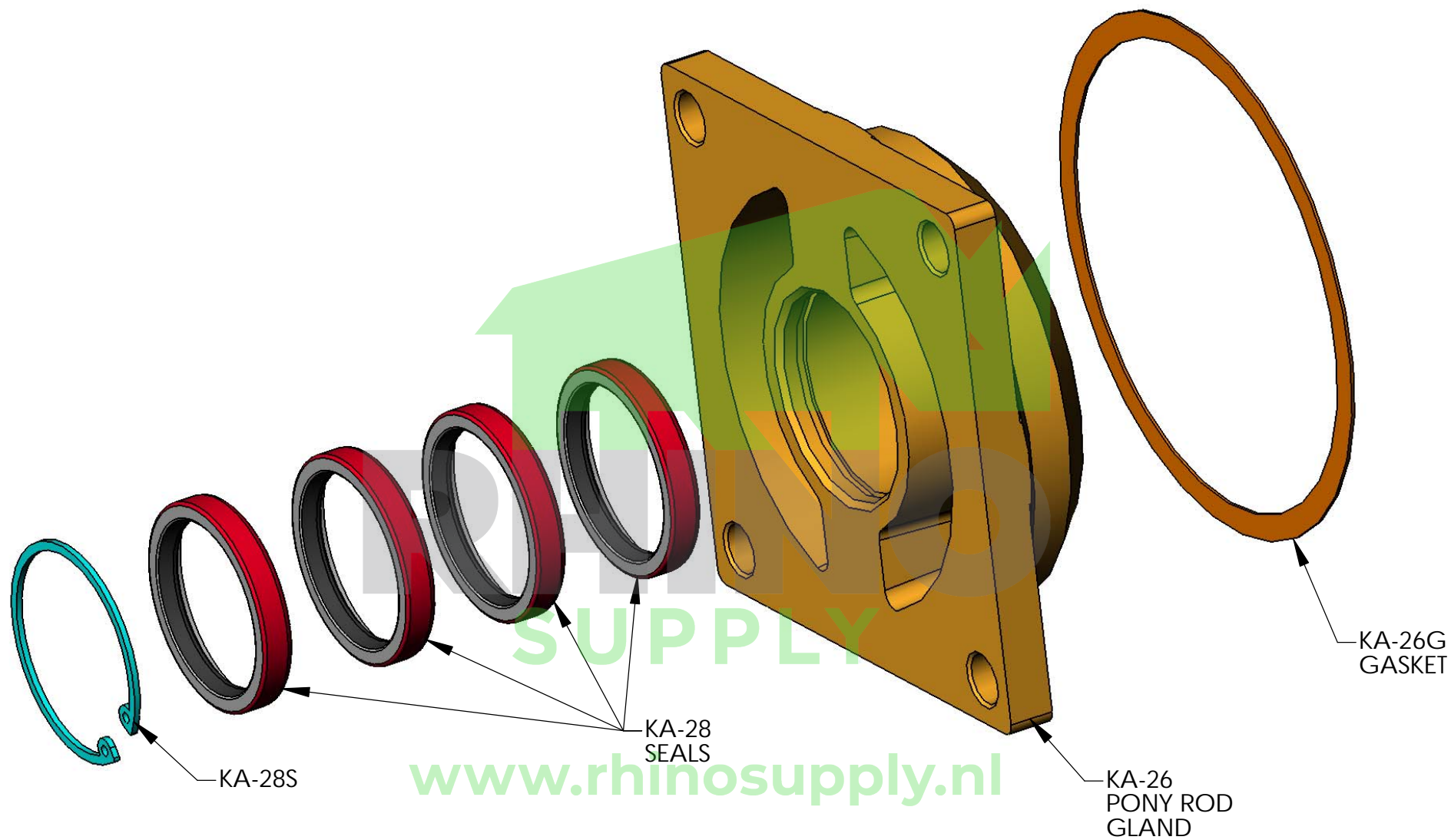

**KA-26-A
PONY ROD
PACKING GLAND
ASSEMBLY**

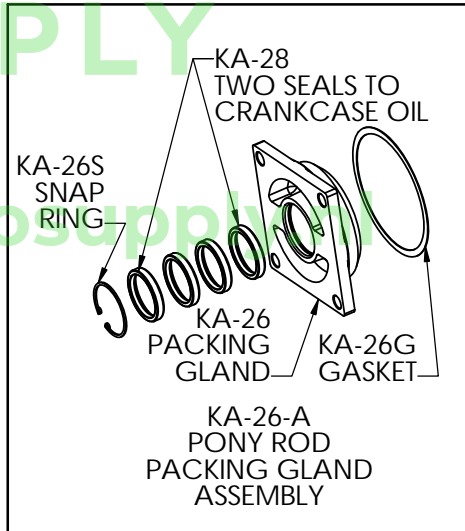
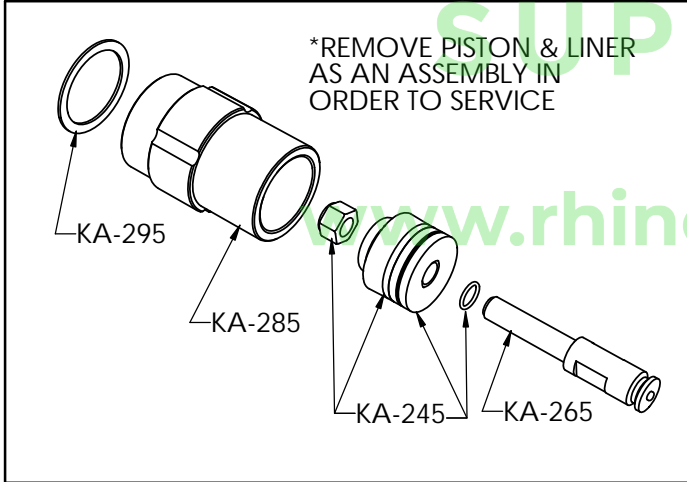
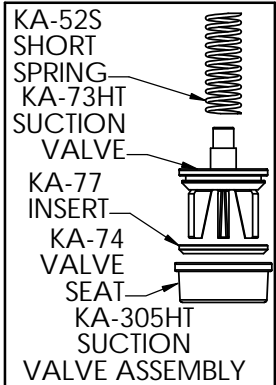
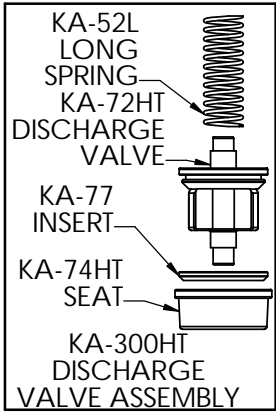
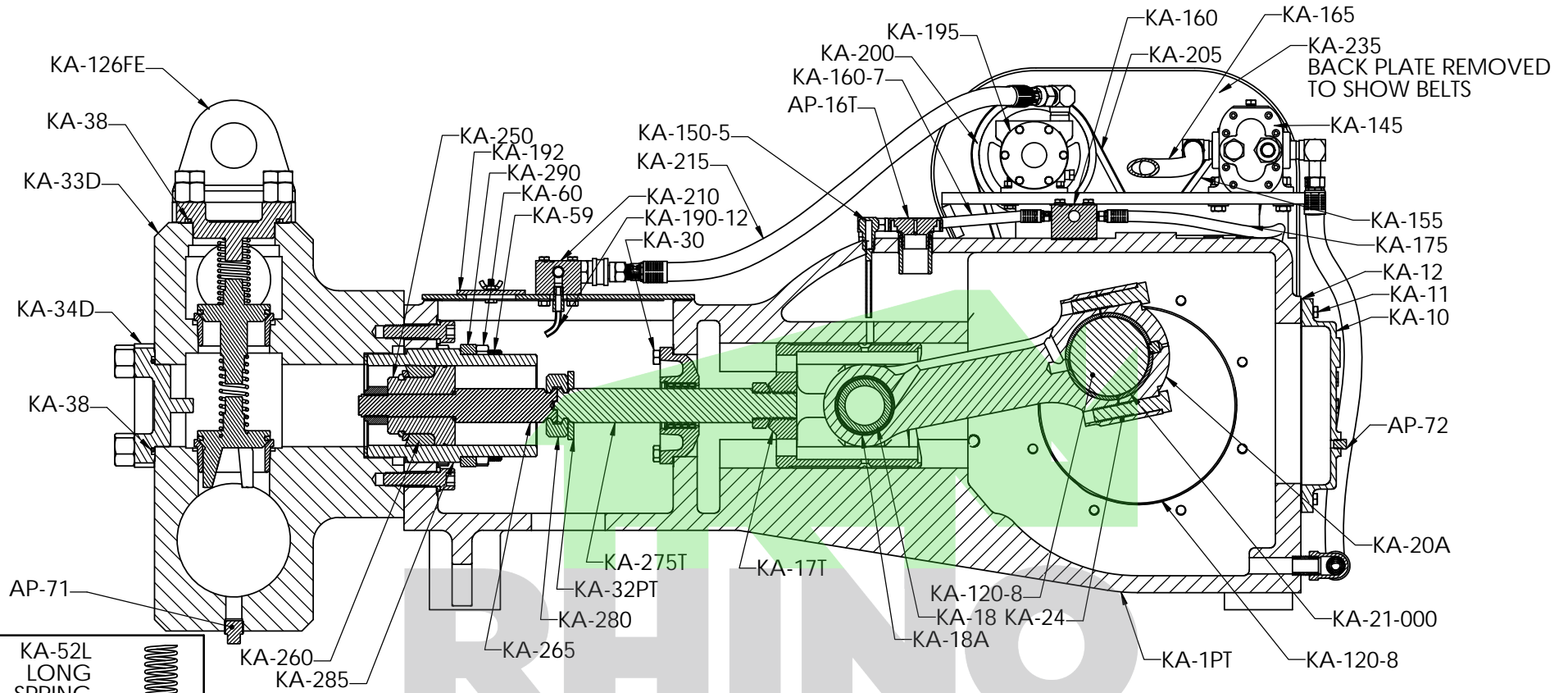

TROUBLESHOOTING GUIDE
for Kerr Pump

- 1) CHECK FOR LEAKING PISTONS
- REPLACE IF NECESSARY
- 2) CHECK FOR PROPER FLUID FLOW
TO PUMP
- MINIMUM REQUIREMENTS 3"
SUCTION HOSE NO MORE THAN 50'
LONG WITH 30 PSI OF CONTINUOUS
PRESSURE FEEDING PUMP
- 3) REMOVE VALVE COVER CAPS AND
INSPECT VALVES & VALVE SEATS
FOR FOREIGN OBJECTS AND WEAR
- REPLACE IF NECESSARY

KA-3500PT

Kerr KA-3500PT Piston Type Pump

Part Number	Description	# Req
KA-1PT	Pump Case	1
KA-3	Crankshaft Oil Seal	1
KA-6	Bearing Housing Capscrews	9
KA-6B	Bearing Housing Capscrews 2	3
KA-7	Bearing Housing Gaskets	2
KA-8-015	Main Bearing Adjusting Shims .015	
KA-8-010	Main Bearing Adjusting Shims .010	
KA-8-005	Main Bearing Adjusting Shims .005	
KA-9	Main Bearings	2
KA-10	Pan Cover	1
KA-11	Pan Cover Capscrews	14
KA-12	Pan Cover Gasket	1
AP-16T	Breather Cap (Oil Filler) Threaded Style	1
AP-16	Breather Cap (Oil Filler)	1
KA-17T	Crosshead Tapered	3
KA-18	Wrist Pin	3
KA-18A	Wrist Pin Bushing	3
KA-19	Wrist Pin Set Screws & Nut	3
KA-20A	Connecting Rod (Inserted Both Ends)	3
KA-20	Connecting Rod Only (No Inserts - Requires inserts both ends)	3
KA-21-000HRL	Connecting Rod Insert Bushing (Std)	3
KA-21-030	Connecting Rod Insert Bushing (.030)	3
KA-21-015	Connecting Rod Insert Bushing (.015)	3
KA-21-000	Connecting Rod Insert Bushing (Std)	3
KA-22	Connecting Rod Capscrew	6
KA-24	Connecting Rod Shims (Laminated)	6
KA-26M-A	Pony Rod Gland Assembly (Pony Rod Gland, Snap Ring, 2 Seals, & 1 Wiper)	3
KA-26M	Pony Rod Gland Snap Ring Type for KA-29 Seal Kit	3
KA-26S	Pony Rod Gland Snap Ring	3
KA-26G	Pony Rod Gland Gasket	3
KA-26A	Pony Rod Gland Assembly (Pony Rod Gland, Snap Ring, Seals)	3
KA-26	Pony Rod Seal Gland Snap Ring Type	3
KA-28	Pony Rod Seal (4 Seals per Set)	3 sets
KA-29	Pony Rod Seal Kit (2 Seals & 1 Wiper per Set)	3
KA-30	Pony Rod Gland Capscrews	12
KA-32PT	Pony Rod Splash Guard	3
KA-33-2500	3 to 2 1/2 Bushing	1
KA-33-500	3 to 1/2 Bushing	1
KA-33-2000	3 to 2 Bushing	1

Part Number	Description	# Req
KA-33DM	Fluid End Vessel Only (Ductile)	1
KA-34D	Top Cover Cap (Ductile)	3
KA-35D	End Cover Cap (Ductile)	3
KA-36B	Cover Cap Bracket Stud	2
KA-36	Cover Cap Stud	22
KA-37	Cover Cap Stud Nut	24
KA-38N	Cover Cap O' Ring (Nitrile)	6
KA-38A	Cover Cap O' Ring (Aflas)	6
KA-42-3	Valve Spring	10
KA-52S	Valve Spring (Suction) (Short)	3
KA-52CW	Valve Spring	6
KA-52L	Valve Spring (Discharge) (Long)	3
KA-59T	Fluid End / Liner Retainer Lineup Studs	2
KA-59CS	Fluid End Capscrews	6
KA-59	Fluid End / Liner Retainer Studs	10
KA-60	Fluid End / Liner Retainer Stud Nuts	24
KA-68MH	Valve Puller Wing Type (Hydraulic)	1
KA-68M-5	O-Ring, Puller	1
KA-68M-5	Nut, Puller	1
KA-68M-4	Spacer Washer, Puller	1
KA-68M-3	Head, Puller	1
KA-68M-2	Pin Set, Puller	3
KA-68M-1	Rod, Puller	1
KA-68M	Valve Puller Wing Guide Pin Type	1
KA-68	Valve Puller Wing Type	1
AP-71	Drain Plug	1
AP-72	Oil Level Plug	3
KA-072HT	Discharge Valve, Heat Treated, A/R with Insert	3
KA-073HT	Suction Valve, Heat Treated, A/R with Insert	3
KA-074HT	Valve Seat, Heat Treated, A/R	6
AP-77T	Valve Insert Tool	1
KA-77HT	Abrasive Resistant Valve Insert (High Temperature)	6
KA-77	Abrasive Resistant Valve Insert	6
KP-85	Insert, Caged A/R (Abrasive Resistant) Valve	10
KA-113PT	KA-3500PT Rebuild Gasket Kit Complete Includes the Following Parts:(1) KA-3, (2) KA-7, (1) KA-12, (3) KA-26G, (3) KA-28, (3) KA-32PT, (6) KA-38, (2) KA-127, (1) KA-161, (1) KA-191, (3) KA-295, (1) AP-331	1
KA-120-8TP-2	Crankshaft, Splined Hydraulic Drive TP-2	1
KA-120-8	Crankshaft, Splined Hydraulic Drive 21 Tooth Spline #8 & #9	1
KA-120-6	Crankshaft, Splined Hydraulic Drive 40 Tooth Spline	1
KA-125-8	Bearing Housing, Hydraulic Drive # 8	1
KA-125-6	Bearing Housing, Hydraulic Drive # 6	1

Part Number	Description	# Req
KA-126FE	Fluid End Lifting Eye	1
KA-126BH	Bearing Cap Lifting Eye	1
KA-127	#8 & #9 Auburn Housing Gasket	1
KA-130TP	Bearing Housing, Oil Pump Lubrication System	1
KA-130	Bearing Housing, Extension Shaft Side	1
AP-132	Extension Shaft	1
KA-133-1	O'Ring, Adapter Sleeve	1
KA-133TP	Adapter Sleeve, Oil Pump Lubrication System	1
KA-134-3	Socket Head Capscrews, Pump Oil Lubrication System	4
KA-134-2	O'Ring, Pump Oil Lubrication System	1
KA-134-1	Bushing 1/2 NPT to 1-1/2 NPT Steel	2
KA-134	Pump, Oil Lubrication System	1
AP-135	Oil Seal, Bearing Housing Extension Shaft	1
KA-140RH	Bracket, Oil and Water Pumps (Right-Hand)	1
KA-140LH	Bracket, Oil and Water Pumps (Left-Hand)	1
AP-145	Oil Pump, 1/2 Cast Iron	1
AP-150	Sheave, Oil Pump	1
KA-155	Belt, Oil Pump	1
AP-160-6	Fitting, Female Swivel (Supplied with hose)	3
AP-160-5	Fitting, Crosshead Oil Injector	3
AP-160-4	Oil Manifold Plug	1
AP-160-3	Male Pipe Rigid 1/4 X 1/8 (Supplied with hose)	5
AP-160-2	90 Degree Tube Fitting 1/2 (Supplied with hose)	1
KA-160	Oil Manifold	1
AP-160-1	Oil Manifold 90 Degree Elbow	1
KA-161	Oil Manifold Gasket	1
KA-165TP	Oil Line, Pump Manifold	1
KA-165	Oil Line, Pump Manifold	1
KA-170TP	Oil Line, Pump to Oil Sump	1
KA-170	Oil Line, Pump to Oil Sump	1
KA-175	Oil Line, Manifold to Bearing Housing	2
KA-180	Oil Line, Manifold to Crosshead	3
AP-190-14	1/4-20 UNC Nut	4
AP-190-13	1/4 Lock Washer	4
AP-190-12	Fitting, Water Jet	3
AP-190-11	Piston Chamber Cover Setscrew	2
AP-190-10	Piston Chamber Cover Wing Nut	2
AP-190-9	Piston Chamber Cover Inspection Glass Capscrew	2
AP-190-8	Piston Chamber Cover Inspection Glass Wing Nut	2
AP-190-5	Water Manifold Quick Coupling	1

Part Number	Description	# Req
AP-190-4	Water Manifold 90 Degree Fitting	1
AP-190-3	Water Manifold / Oil Manifold Bolt	4
AP-190-2	Water Manifold Plug	1
KA-190	Piston Chamber Cover	1
KA-190A	Piston Chamber Cover Spray Unit Complete	1
KA-191	Piston Chamber Cover Gasket	1
KA-192	Piston Chamber Cover Inspection Glass	1
AP-195	Water Pump, Bronze	1
AP-197	Water Pump Repair Kit (Nitrile)	1
AP-200-175	Sheave, Water Pump (KA use belt KA-205-037)	1
AP-200-260	Sheave, Water Pump (KA use belt KA-205-038)	1
AP-200-520	Sheave, Water Pump (KA use belt KA-205-039)	1
AP-205-037	Belt, Water Pump (KA use sheave KA-200-175)	1
AP-205-038	Belt, Water Pump (KA use sheave KA-200-260)	1
AP-205-039	Belt, Water Pump (KA use sheave KA-200-520)	1
KA-210	Water Manifold	1
KA-215	Line, Water Pump to Manifold	1
AP-216	3/8 Quick Connect	1
KA-220	Line, Water Pump to Supply Tank	1
KA-225	Line, Water Manifold to Piston Cover	3
KA-230-16	Lock Washer, Pump Oil Lubrication System	4
AP-230-9	Sheave Bushing	1
AP-230	Sheave, Crankshaft Drive to Pumps	1
AP-235-50	Rotation Label	1
AP-235-32	90 Degree Tube Fitting 1/4 (Supplied with hose)	1
AP-235-31	SAE JIC Male Connector 1/4 x 1/8	2
AP-235-27	3/8-16 UNC x 3/8 Setscrew	2
AP-235-24	3/8-16 UNC Hex Head Nut	2
AP-235-23	3/8 Lock Washer	2
AP-235-22	3/8 Flat Washer	2
AP-235-21	3/8-16 UNC x 1 1/4	2
AP-235-19	1/4 Flat Washer	2
AP-235-17	1/4-20 UNC x 1 1/4 Capscrew	2
KA-235RH	Belt Guard, Pump Drive (Right-Hand)	1
KA-235LH	Belt Guard, Pump Drive (Left-Hand)	1
KA-245-400	Piston Complete 4	3
KA-245-350MU	Piston Complete 3 1/2 (Molded Urethane)	3
KA-245-300	Piston Complete 3	3
KA-245-350	Piston Complete 3 1/2	3
KA-246	Piston O' Ring	3

Part Number	Description	# Req
KA-248	Piston Snap Ring Installation Tool	1
KA-250-400	Piston, Body Only 4	3
KA-250-350	Piston, Body Only 3 1/2	3
KA-250-300	Piston, Body Only 3	3
KA-260-400	Piston Cup Kit 4.0(cup, retainer plate, snap ring)	3
KA-260-350	Piston Cup Kit 3.5 (cup, retainer plate, snap ring)	3
KA-260-300	Piston Cup Kit 3 (cup, retainer plate, snap ring)	3
KA-265	Piston Extension Rod	3
KA-270	Piston Extension Rod Lock Nut	3
KA-275	Pony Rod Piston Pump Type	3
KA-276	Installation Tool for Pony Rod Seal	1
KA-277	Pony Rod Installation Wrench	1
KA-280	Clamp, Pony Rod to Piston Rod	3
KA-285-400KER-A	Liner Assembly 4 (Piston complete, rod, locknut, liner kerramic, gasket)	3
KA-285-400CH-A	Liner Assembly 4 (Piston complete, rod, locknut, liner chrome, gasket)	3
KA-285-350KER-A	Liner Assembly 3 1/2 (Piston complete, rod, locknut, liner kerramic, gasket)	3
KA-285-350CH-A	Liner Assembly 3 1/2 (Piston complete, rod, locknut, liner chrome, gasket)	3
KA-285-350CER-A	Liner Assembly 3 1/2 (Piston complete, rod, locknut, liner ceramic, gasket)	3
KA-285-300CH-A	Liner Assembly 3 (Piston complete, rod, locknut, liner chrome, gasket)	3
KA-285-300CER-A	Liner Assembly 3 (Piston complete, rod, locknut, liner, gasket)	3
KA-285-400KER	Liner, 4 Kerramic	3
KA-285-400CH	Liner, 4 Chrome	3
KA-285-350KER	Liner, 3 1/2 Kerramic	3
KA-285-350CH	Liner, 3 1/2 Chrome	3
KA-285-350CER	Liner, 3 1/2 Ceramic	3
KA-285-300CER	Liner, 3 Ceramic	3
KA-285-300CH	Liner, 3 Chrome	3
KA-290	Liner Retainer	3
KA-295	Liner Gasket	3
KA-300	Abrasive Resistant Discharge Valve Complete (72HT, 74HT & 52L)	3
KA-305	Abrasive Resistant Suction Valve Complete (73HT, 74HT & 52S)	3
AP-306	Valve Seat Seating Tool	1
AP-320	Flow Meter	1
AP-324-9	# 9 Planetary Gear Assembly	1
AP-324-8	# 8 Planetary Gear Assembly	1
KA-325	Planetary Adapter Kit 6 to 8	1
KA-326	Spline Adapter (21-40)	1
KA-327	Spline Adapter Spacer	1
AP-330-2	Snap Ring, SAE C 4 Bolt Drive Assembly 1-1/2 Male Input Shaft	1
AP-330-1	Oil Seal, SAE C 4 Bolt Drive Assembly 1-1/2 Male Input Shaft	1