

KA-3500PT 172 BHP Triplex Piston Pump

Intermittent Duty

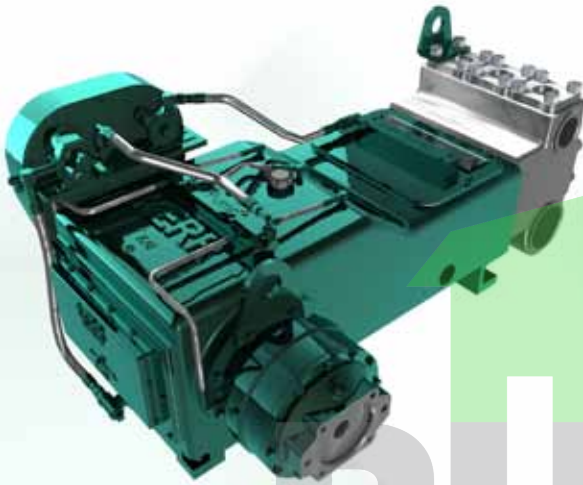

SPECIFICATIONS

Configuration	Horizontal Triplex Piston
Number of Plungers	3
Stroke Length	5" / 127 mm
Frame Load Rating	10,603 lbs
Fluid Cylinder Pressure Rating	2,160 PSI
Pump Weight (Avg.)	1,900 lbs / 864 kilos
Kerr Max Speed	385 RPM
Minimum Speed	100 RPM
Mechanical Efficiency (Bare Shaft)	90%
Lube System (Standard)	Splash - Gravity Feed
Lube System (Optional)	Force Feed
Lube Oil Capacity	24 quarts / 22.75 liters
Lube Oil Type	Pertroleum per AGMA 5EP (ISO 220) or Synthetic per SAE 75W-90 (ISO 100)
Connection Sizes	5" NPT Suction 3" NPT Discharge

RHINO
SUPPLY

FLUID END

Cast Ductile Iron
Other materials available on request

www.rhinosupply.nl

VALVES

WING GUIDED	
17-4 HT / AR Urethane Inserted	

PISTONS / LINERS

Rubber / Ceramic Sleeved
Rubber / Chrome Plated-Sleeved
Rubber / Kerramic (Ceramic) Coat

* Consult Factory for Authorized Drawings for Dimensions

1) Displacement is based on 100% Volumetric Efficiency (VE)

2) Consult factory for operating speeds above maximum shown

KA-3500PT 172 BHP Triplex Piston Pump

Intermittent Duty

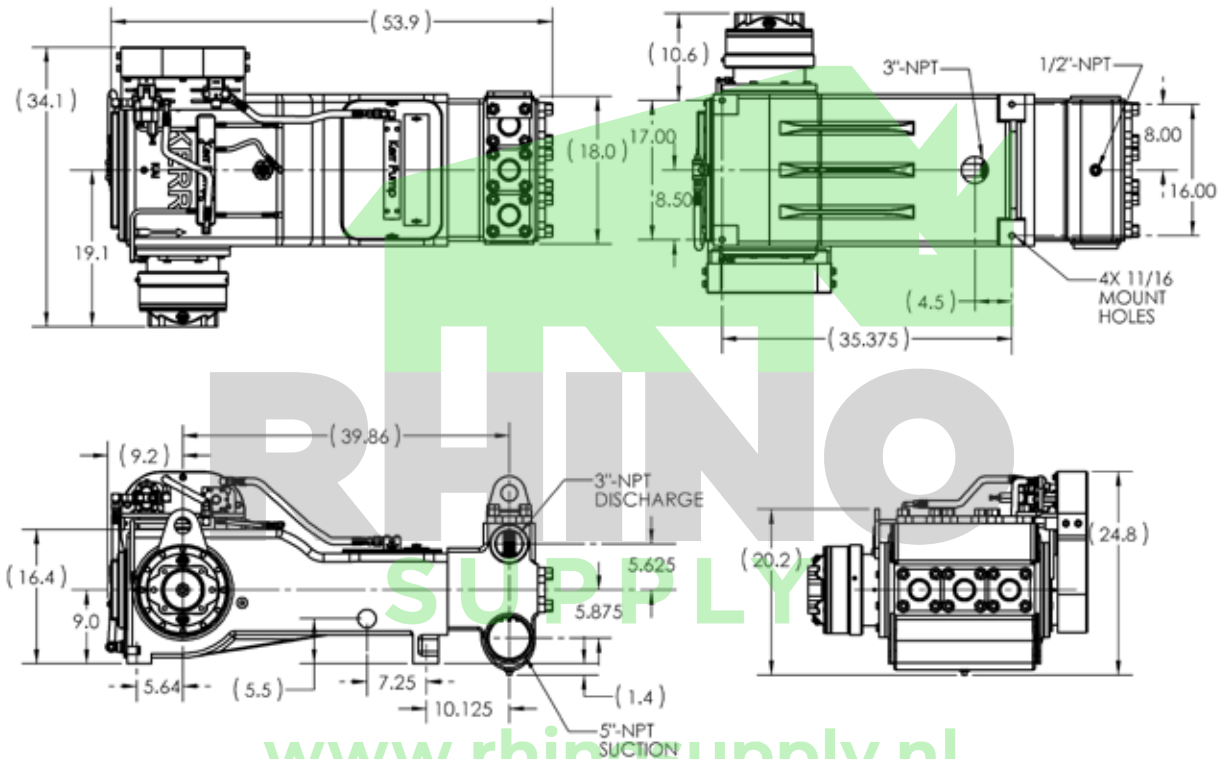
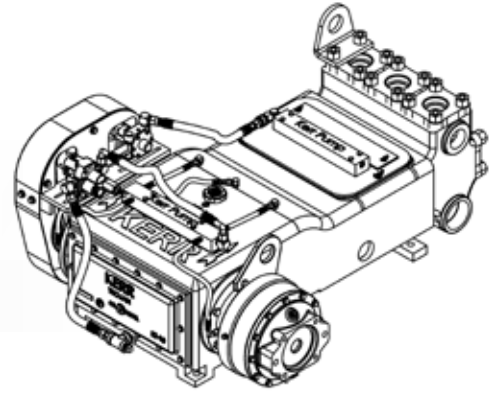

www.rhinosupply.nl

PIST DIA. INCHES	MAX PRESS PSI	DISP GAL PER REV	DISPLACEMENT																	
			100 RPM		140 RPM		175 RPM		210 RPM		245 RPM		280 RPM		315 RPM		350 RPM		385 RPM	
			GPM	BPD	GPM	BPD	GPM	BPD	GPM	BPD	GPM	BPD	GPM	BPD	GPM	BPD	GPM	BPD	GPM	BPD
3.000	1500	0.4590	45.9	1574	64.3	2204	80.3	2755	96.4	3306	112	3857	129	4408	145	4959	161	5510	177	6061
3.500	1102	0.6247	62.5	2143	87.5	3000	109.3	3750	131.2	4500	153	5250	175	6000	197	6750	219	7500	N/A	N/A
4.000	844	0.8160	81.6	2799	114	3918	142.8	4898	171.4	5878	200	6857	228	7837	N/A	N/A	N/A	N/A	N/A	N/A

* Consult Factory for Authorized Drawings for Dimensions

1) Displacement is based on 100% Volumetric Efficiency (VE)

2) Consult factory for operating speeds above maximum shown