

KP-3300PT 78 BHP Triplex Piston Pump

Intermittent Duty

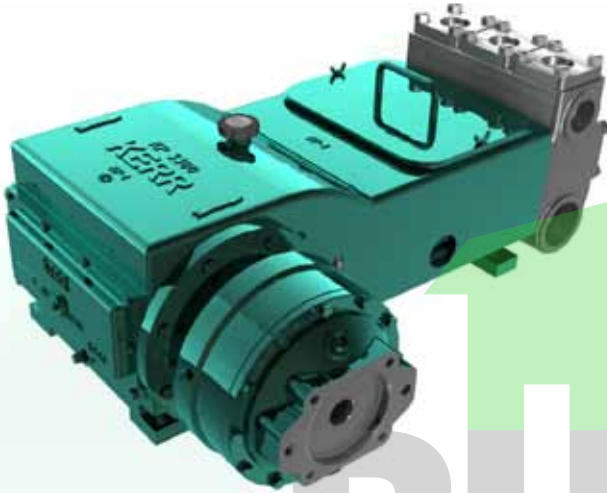

SPECIFICATIONS

Configuration	Horizontal Triplex Piston
Number of Plungers	3
Stroke Length	2.5" / 63.5 mm
Frame Load Rating	7,210 lbs
Fluid Cylinder Pressure Rating	3,600 PSI
Pump Weight (Avg.)	1,000 lbs / 455 kilos
Kerr Max Speed	470 RPM
Minimum Speed	100 RPM
Mechanical Efficiency (Bare Shaft)	90%
Lube System (Standard)	Splash - Gravity Feed
Lube System (Optional)	Force Feed
Lube Oil Capacity	12 quarts / 11.36 liters
Lube Oil Type	Petroleum per AGMA 5EP (ISO 220) or Synthetic per SAE 75W-90 (ISO 100)
Connection Sizes	3" NPT Suction 2" NPT Discharge

RHINO
SUPPLY

FLUID END

Cast Ductile Iron
Other materials available on request

www.rhinosupply.nl

VALVES

WING GUIDED	
17-4 HT / AR Urethane Inserted	

PISTONS / LINERS

Rubber / Ceramic Sleeved
Rubber / Chrome Plated-Sleeved
Rubber / Kerramic (Ceramic) Coat

* Consult Factory for Authorized Drawings for Dimensions

1) Displacement is based on 100% Volumetric Efficiency (VE)

2) Consult factory for operating speeds above maximum shown

KP-3300PT 78 BHP Triplex Piston Pump

Intermittent Duty

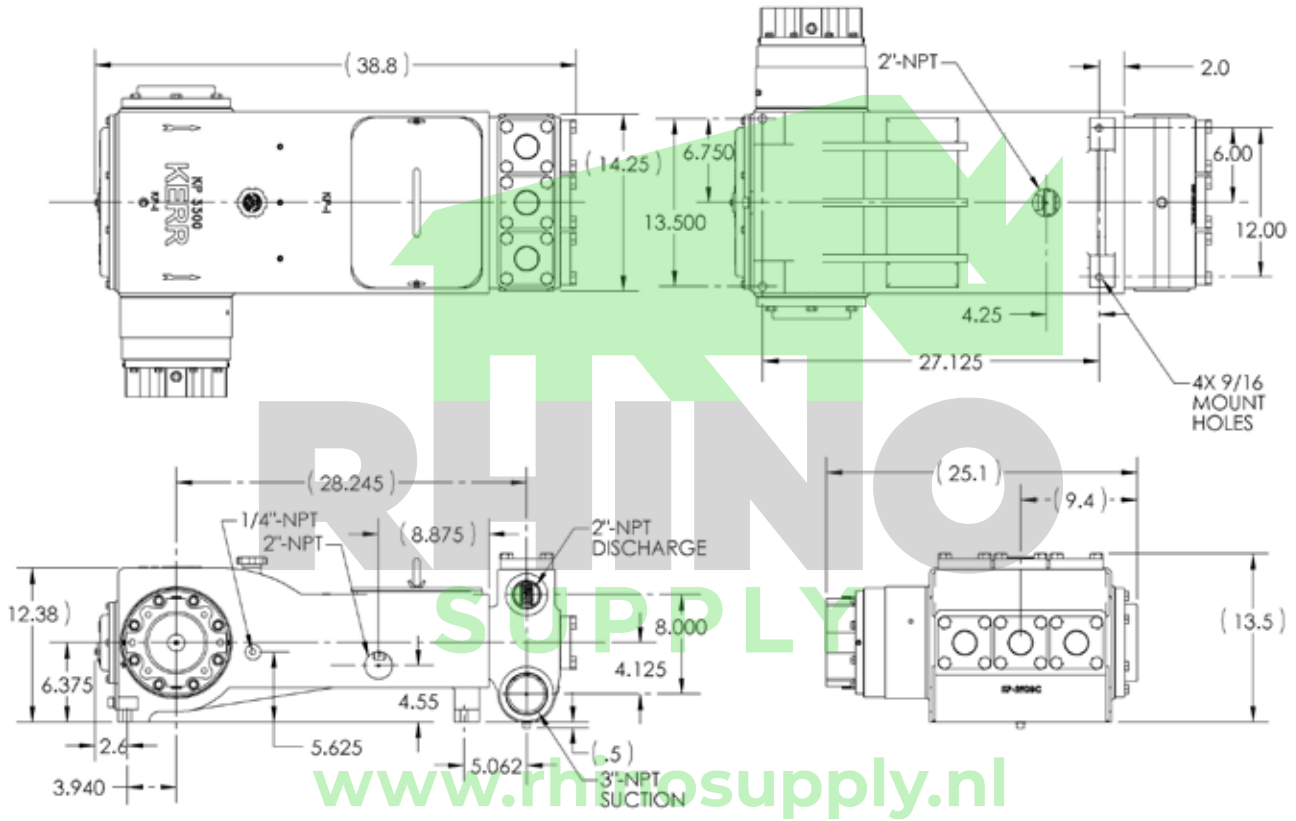
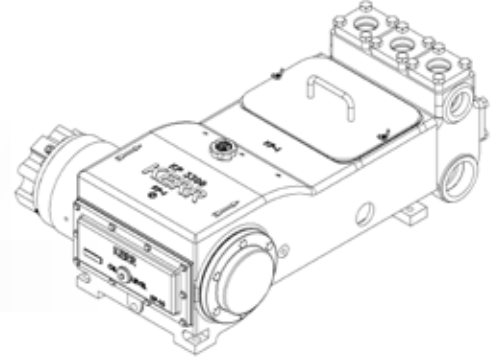

PIST DIA. INCHES	MAX PRESS PSI	DISP GAL PER REV	DISPLACEMENT																	
			100 RPM		155 RPM		200 RPM		245 RPM		290 RPM		335 RPM		380 RPM		425 RPM		470 RPM	
			GPM	BPD	GPM	BPD	GPM	BPD	GPM	BPD	GPM	BPD	GPM	BPD	GPM	BPD	GPM	BPD	GPM	BPD
2.500	1469	0.1594	15.9	547	24.7	847	31.9	1093	39.0	1339	46.2	1585	53.4	1831	60.6	2077	67.7	2323	74.9	2569
2.750	1214	0.1928	19.3	661	29.9	1025	38.6	1323	47.2	1621	55.9	1918	64.6	2216	73.3	2514	82.0	2811	90.6	3109
3.000	1020	0.2295	22.9	787	35.6	1220	45.9	1574	56.2	1929	66.6	2283	76.9	2637	87.2	2991	97.5	3346	107.9	3700

* Consult Factory for Authorized Drawings for Dimensions

1) Displacement is based on 100% Volumetric Efficiency (VE)

2) Consult factory for operating speeds above maximum shown