



MCM

CENTRIFUGAL PUMPS

Houston, Texas

Since 1943

ISO 9001:2015 CERTIFIED



.... *Leading the way*

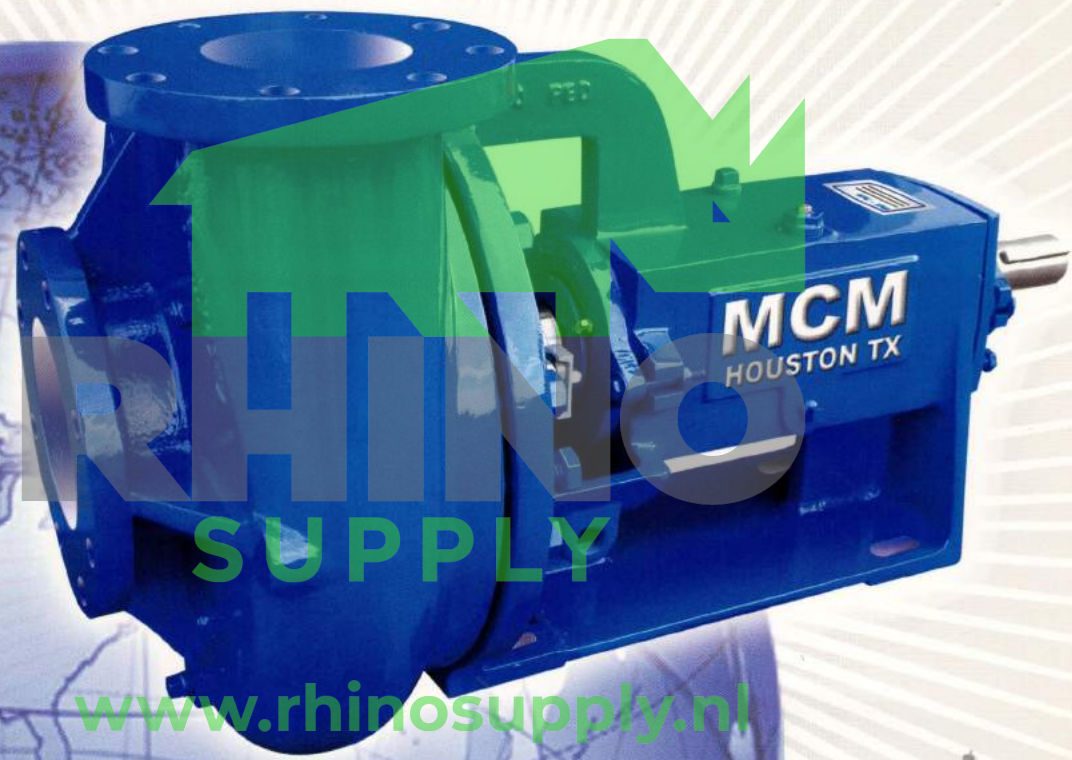

Series

- 118
- 178
- 250
- Mud Master
- Cyclone Pump
- Skid Packages

www.rhinosupply.nl

MANUFACTURING • SALES • SERVICE



O'DRILL • MCM INDUSTRY LEADER!

MCM 250 Series Pump

Toughest...

The "Extra Heavy" duty MCM 250 series pump has been designed for the toughest jobs in drilling, production, well servicing and other industrial applications.



250 Series Pumps feature a 2 1/2" shaft, replaceable shaft sleeve and stuffing box and a thicker concentric housing. This series is available in eight sizes (2x3x13, 3x4x13, 4x5x14, 5x6x11, 5x6x14, 6x8x11, 6x8x14 and 8x10x14).

MCM Mud Master

The MCM Mud Master is a compact version of our MCM 250 Series pump. It's designed to be a **space saver**. Applications include frac trucks, blending and pump charging services. The MCM Mud Masters variable hydraulic drive make it a good choice for water well drilling services.



Direct Applications

- Cement & Blender
- Water well drilling

MCM 178 Series Pump

Tougher...

178 Series Pumps have a 1 1/8" shaft and a two piece concentric housing which can be reversed for either right or left hand rotation. This series is available in five sizes (2x3, 3 x 4, 4x5, 5x6 and 6x8).



Direct Applications

- Pulp and Paper
- Chemical Process Industry
- Sewage Treatment

MCM Cyclone Pump (vortex type)

The main frame of the MCM Cyclone Pump is the same as MCM 250 however the housing is extended by a special concentric tube to accommodate its special straight vane impeller. The MCM straight vane impeller produces a certain dynamic vacuum which causes a certain whirl-wind effect allowing the fluids and slurries to circulate in the housing without actually passing through the impeller. Fibers such as pulp and solid pass through the discharge without getting clogged.

ISO
9001:2015
CERTIFIED

MCM 118 Series Pump

Tough...

118 Series Pumps feature a 1 1/8" shaft and a one piece concentric housing. It is available in four sizes for right or left hand rotation. (1x1 1/2, 1 1/2 x 2, 2x3, and 3x4).



MCM Skid Packages

Vertical or Horizontal



...a pump for every application.

www.rhinosupply.nl

Table of Contents

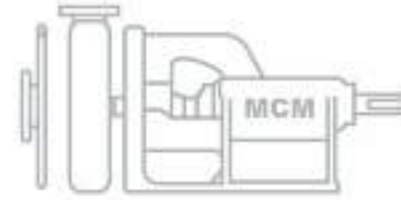

APPLICATIONS	4
PROPER PUMP SELECTION	5
PUMP PERFORMANCE COMPUTATIONS	6
INSTALLATION AND OPERATION SUGGESTIONS	7
START-UP & OPERATION / MATERIAL CODES	8
118 SERIES	
PARTS DIAGRAM	9
PUMP PARTS AND SIZES	10
PARTS OPTIONS	11
FEATURES	12
PUMP DIMENSIONAL OUTLINE	13
PERFORMANCE CURVES	15-21
178 SERIES	
FEATURES	22
PARTS DIAGRAM	23
PUMP PARTS AND SIZES	24
PARTS OPTIONS	25
PUMP DIMENSIONAL OUTLINE	27
PERFORMANCE CURVES	28-36
250 SERIES	
PARTS DIAGRAM	37
PUMP PARTS AND SIZES	38
PARTS OPTIONS	39
FEATURES	40
PUMP DIMENSIONAL OUTLINE	41
PERFORMANCE CURVES	42-55
DIMENSIONAL DATA (Frame Sizes & Fabricated Bases)	56
CONVERSION DATA	57
ENGINEERING DATA	58
ENGINEERING TABLES	59-60
PUMP TROUBLES AND REMEDIES	62

Look & compare... MCM Pump is your Best Choice!

Applications



- **MEDIUM AND HEAVY DUTY WASHDOWN**

Pump sizes are available with capacities of up to 400 GPM at pressures up to 125 PSI.

- **MEDIUM AND HEAVY DUTY SUPERCHARGING**

Pump sizes are available to supercharge slush pumps at volumes up to 1200 GPM at 30 PSI. This is usually sufficient pressure to overcome pump entrance losses and to accelerate the fluid in the suction line.

- **DESANDING AND DESILTING**

Pump sizes are available for feeding desanders and desilters with capacities up to 1200 GPM at 35 to 45 PSI. This is ideal for proper cone performance.

- **MUD PROCESSING**

Pump sizes are available with capacities up to 1600 GPM and pressures to 35 PSI. This pressure provides adequate shearing action for blending of water and mud to form smooth, even slurries. The high volume makes for a fast and efficient operation.

- **SALTWATER DISPOSAL AND WATER FLOODING**

MCM pumps for handling salt water are corrosion resistant, durable, and maintenance free. They can be specially designed and sized to meet the requirements of each application. Pumps can be furnished with fluid end-parts made of cast iron, aluminum-bronze, or stainless steel, with capacities up to 1600 GPM and pressures up to 150 PSI.

- **WATER WELL DRILLING**

MCM Centrifugal Pumps with their high volume, low pressure performance offer an excellent alternative to reciprocating, positive displacement pumps for water well drilling. The large volume of fluid is needed to keep the hole clean. However, the drilling unit must be designed to take advantage of the high volume, low pressure system. This is accomplished by using oversize water passages through the drill bit, large swivel passages, and large diameter drill pipe. With a properly designed system, the MCM Centrifugal Pump can be used to depths of 1000 feet, with well bores up to 20 inches.

- **INDUSTRIAL TRANSFER PUMPING**

MCM pumps are available for pumping slurries and sludge containing solids from 13 / 16" to 1 3/8" maximum diameter, with volumes to 3,000 GPM and pressures to 150 PSI.



OTHER APPLICATIONS

- Supercharging Plunger Pumps
- Drilling Rig Brake Cooling
- Food Processing
- Chemical Processing
- Irrigation Transfer
- Pumping All Types of Slurries
- Refinery Transfer Pumps
- Construction and Industrial Pumps
- Mining and Related Industry
- All Types of High Volume Low Pressure Fluid Pumping

NEW!

MCM's Offers Special Coating for Increased Hardness & Corrosion Resistance

MCM has the perfect and economical solution with its **space age** surface enhancement coating which protects most metals against wear, corrosion, sticking and galling. This coating will increase your impeller or housing life by 2 to 3 times.

FEATURES:

- Dramatically increases surface hardness beyond 65 Rockwell, better than hard chrome materials, there is no degradation of fatigue strength.
- Resists corrosion, chemicals and acids.
- Prevents abrasive wear & galling. This coating is superior in corrosion resistance to chromium or standard electrolytic Nickel plated coatings.
- Self lubricating for extended wear life.
- Meets specs mil -C-26074 class 1,2,3 & 4.
- Replaces coatings for salts and chemicals
- Replaces heat treating for hardness.

Allow MCM an opportunity to dramatically improve on your coated and high abrasive requirements, you will see amazing results with great savings!

MCM also does carbide coated impellers at an economical cost. Call us today!



Careful selection and installation of the correct **MCM** Centrifugal Pump will result in a unit that will provide long-lasting and dependable service. Selecting a pump with excessive pressure capability means extra horsepower expense. Centrifugal pumps have much different horsepower input characteristics than positive displacement pumps. However, if the pressure requirements on the discharge side are indefinite, or if for some other reason the discharge pressure is much lower than expected, the pump will handle considerably more fluid and require more horsepower than originally selected to drive the pump. A valve or flow restriction will then be required to increase the discharge pressure and reduce the horsepower needed to drive the pump.

To assure proper pump selection, the following information is required:

1. Suction conditions:

- A. Size of suction piping
- B. Length of suction line
- C. Flooded suction (positive)
- D. Suction lift (negative)

2. Total discharge head required.

3. Rate of flow desired.

4. Type of driver desired and RPM (electric motor or engine)

5. Specific gravity or weight of fluid to be pumped.

6. Temperature of fluid.

7. Any information available as to the corrosiveness or abrasiveness of the fluid to be handled.

Once this information is obtained it is used to calculate:

GPM = Rate of flow desired **HD. FT.** = Total dynamic head **SP. GR.** = Specific gravity of fluid

PUMP SIZE AND HORSEPOWER SELECTION FROM PERFORMANCE CURVES

Using the desired GPM and head feet, find the pump size and speed by looking at the performance curves. Mark the desired operating point on the performance curve. This operating point may appear on more than one curve because of different speeds and impeller sizes available. Use the variable speed curves for gasoline or diesel engines. If an electric motor is to be used, remember the lower the RPM, the longer the service-life of the pump. Now, decide on the curve that best suits the application of desired GPM, head feet, and RPM. This curve will designate the proper pump size. Refer to the desired operating point and take an impeller size reading

1. Select the impeller size:

- A. For speeds of 1750 RPM and below read to the nearest 1/4 inch above the operating point.
- B. For speeds above 1750 RPM, read to the nearest 1/8 inch above the operating point.

2. Calculate the required horsepower:

- A. Read horsepower from curve at operating point on impeller (selected as accurately as possible) then:

$$\text{Brake Horsepower Required} = \text{Curve HP} \times \text{Sp. Gr. of Fluid}$$

- B. Alternate Method: Read Efficiency at the operating point.

$$\text{Brake Horsepower} = \frac{(\text{GPM}) (\text{Hd. Ft.}) (\text{Sp. Gr.})}{(3960) (\text{Efficiency})}$$

3. Calculate your systems NPSH available in feet:

$$\text{NPSH available} = P^{\wedge} - \text{Friction loss} + \text{Elevation} - \text{Vapor Pressure}$$

P^{\wedge} = Absolute pressure above liquid in feet of fluid
 Absolute Pressure = Gauge Pressure + Atmospheric Pressure
 Elevation = Distance from Surface of liquid on suction side to center line of pump in feet (above +: Below -).

Vapor Pressure = Vapor Pressure fluid at pumping temperature in feet of fluid.

4. Read NPSH required from curve.
- A. NPSH available must be equal to or greater than NPSH required or the pump will cavitate.
 - B. If NPSH required, is greater than NPSH available, consider:
 - (1) Using larger suction pipe to lower losses
 - (2) Raising the fluid level
 - (3) Oversizing the pump
 - (4) Lowering pump Speed and increasing impeller diameter to meet the same operating point.

PUMP PERFORMANCE COMPUTATIONS:

To compute pump performance of variations from pump curves use the following formulas: (Approximate)

CHANGE OF SPEED (RPM)

$$V_2 = V_1 (R_2 / R_1)$$

$$H_2 = H_1 (R_2 / R_1)^2$$

$$P_2 = P_1 (R_2 / R_1)^3$$

CHANGE OF IMPELLER DIAMETER

$$V_2 = V_1 (D_2 / D_1)$$

$$H_2 = H_1 (D_2 / D_1)^2$$

$$P_2 = P_1 (D_2 / D_1)^3$$

CHANGE OF SPEED AND IMPELLER DIAMETER

$$V_2 = V_1 (R_2 / R_1) (D_2 / D_1)$$

$$H_2 = H_1 (R_2 / R_1)^2 (D_2 / D_1)^2$$

$$P_2 = P_1 (R_2 / R_1)^3 (D_2 / D_1)^3$$

VAPOR PRESSURE OF WATER FOR ESTIMATING	
TEMPERATURE	VAPOR PRESSURE IN FEET OF HEAD
80°	1.2
120°	3.9
140°	6.8
160°	11.2
180°	17.8

www.rhinosupply.nl

V ₁	= Old Volume
V ₂	= New Volume
H ₁	= Old Head Feet
H ₂	= New Head Feet
P ₁	= Old Horsepower
P ₂	= New Horsepower
R ₁	= Old Speed (RPM)
R ₂	= New Speed (RPM)
D ₁	= Old Impeller Diameter
D ₂	= New Impeller Diameter



Cut Away View

Installation and Operation Suggestions

The right kind of installation can make considerable difference to the service obtained from a centrifugal pump. A poor design of the suction will cause reduced capacity, and may result in cavitation in the fluid end of the pump. Cavitation can reduce the pump's service life considerably. For pumps handling salt water, a positive suction head is particularly desired, to prevent corrosive gases from coming out of the fluid at the impeller eye.

LOCATION:

Locate the pump as close to the liquid supply as practical so that the suction lift will be low and as short and direct as possible. The pump should be accessible for inspection and maintenance.

BASE:

The base of the pumping unit must be adequately supported on a flat surface in order to maintain proper alignment of pump and motor and to guard against shifting support which could cause line strains.

SUCTION PIPING:

The suction piping should never be less than the size of the suction flange. It is recommended that the suction piping be at least one inch larger than the suction flange whenever possible. The suction line should have a straight run going into the pump of a minimum length of two times its diameter. Air pockets in the suction piping should be eliminated by sloping the line downwards to the source of supply and using an eccentric reducer at the suction flange. Bends or elbows should have long radius to minimize friction lost. A flooded suction will require a butterfly valve installed in the line to permit closing of the line for inspection and maintenance. A lift suction will require a foot valve for priming where a vacuum pump is not used. All piping should be independently supported and accurately aligned and, preferably, connected to the pump by non-collapsing flexible piping to eliminate line strains.

DISCHARGE PIPING:

A pressure gauge and butterfly valve should be installed in the discharge line. The butterfly valve is required for regulating the flow capacity and discharge pressure and to isolate the pump from the discharge fluid for inspection and maintenance. All piping should be independently supported to eliminate line strain and misalignment.

COUPLING ALIGNMENT:

Good service life of the pump, driver, and drive coupling depends upon good alignment through the flexible drive coupling. Poor alignment may cause failure of the pump and motor bearings or of either shaft. After the piping has been connected, the pump unit must be rechecked for proper alignment of the pump shaft and motor shaft through the coupling. The recommended procedure for coupling alignment is by the use of a dial indicator. Information regarding the tolerance in alignment for couplings is usually supplied by the coupling manufacturer.

ROTATION:

The direction of rotation of pump and driver should be checked. They should rotate in the same direction.

NOTE: Never adjust the pump's capacity by throttling the suction line.

Start-up and Operation



BEARING LUBRICATION:

See that the oil chamber is filled to the correct oil level as indicated by the oil dip stick. Use any good brand SAE 30 wt. non-detergent automotive type oil. **DO NOT OVERFILL.**

STUFFING BOX PACKING:

At start-up with new packing in the stuffing box, the gland bolts should be only finger tight. After fifteen to twenty minutes of operation, tighten the gland bolts slowly until the stuffing box drips about six to ten drops per minute. The packing should be greased about every four hours.

PRIMING:

Vent air from suction line and pump housing to allow them to fill completely with fluid while priming. For pumps with a flooded suction, slightly open the discharge valve and fully open the suction valve. This will allow the pump and suction line to fill completely.

START-UP:

Start the pump with the discharge valve about one third open. After the discharge pressure stabilizes, gradually open the discharge valve to the required position.

• **118 Series** - Pumps with **1 1/8" Shaft & Pedestal**

• **178 Series** - Pumps with **1 7/8" Shaft & Pedestal**

• **250 Series** - Pumps with **2 1/2" Shaft & Pedestal**

MATERIAL CODES

- C - Cast Iron
- D - Ductile Iron
- A - Aluminum Bronze
- S - Stainless Steel

ROTATION

- R Right Hand
 - L Left Hand
- (as viewed from shaft end).

IMPELLER SIZE CODE (THREE DIGITS)

1st & 2nd Digits Gives the diameter of impeller in whole inches,

3rd Digit Gives fractions of an inch in /8ths.

Example: 084 = 8½ inches, 130 = 13", 106 = 10^{3/4"}

PUMP SIZE DESIGNATION:

118	1½"	x	2"	C	R	084
SERIES	DISCHARGE		SUCTION	FLUID END CONSTRUCTION	ROTATION	IMPELLER SIZE

STANDARD MATERIALS FOR STANDARD PUMPS

PEDESTAL	Cast Iron	Cast Iron	Cast Iron	Cast Iron	Cast Iron
HOUSING	Cast Iron	Ductile Iron	Aluminum Bronze	Cast Iron	316-SS
IMPELLER	Cast Iron	Ductile Iron	Aluminum Bronze	Aluminum Bronze	316-SS
WEAR PLATE	Cast Iron	Ductile Iron	Aluminum Bronze	Aluminum Bronze	316-SS
SHAFT	416-SS (ceramic)	416-SS (ceramic)	316-SS	316-SS	316-SS

118 SERIES *Parts Diagram*

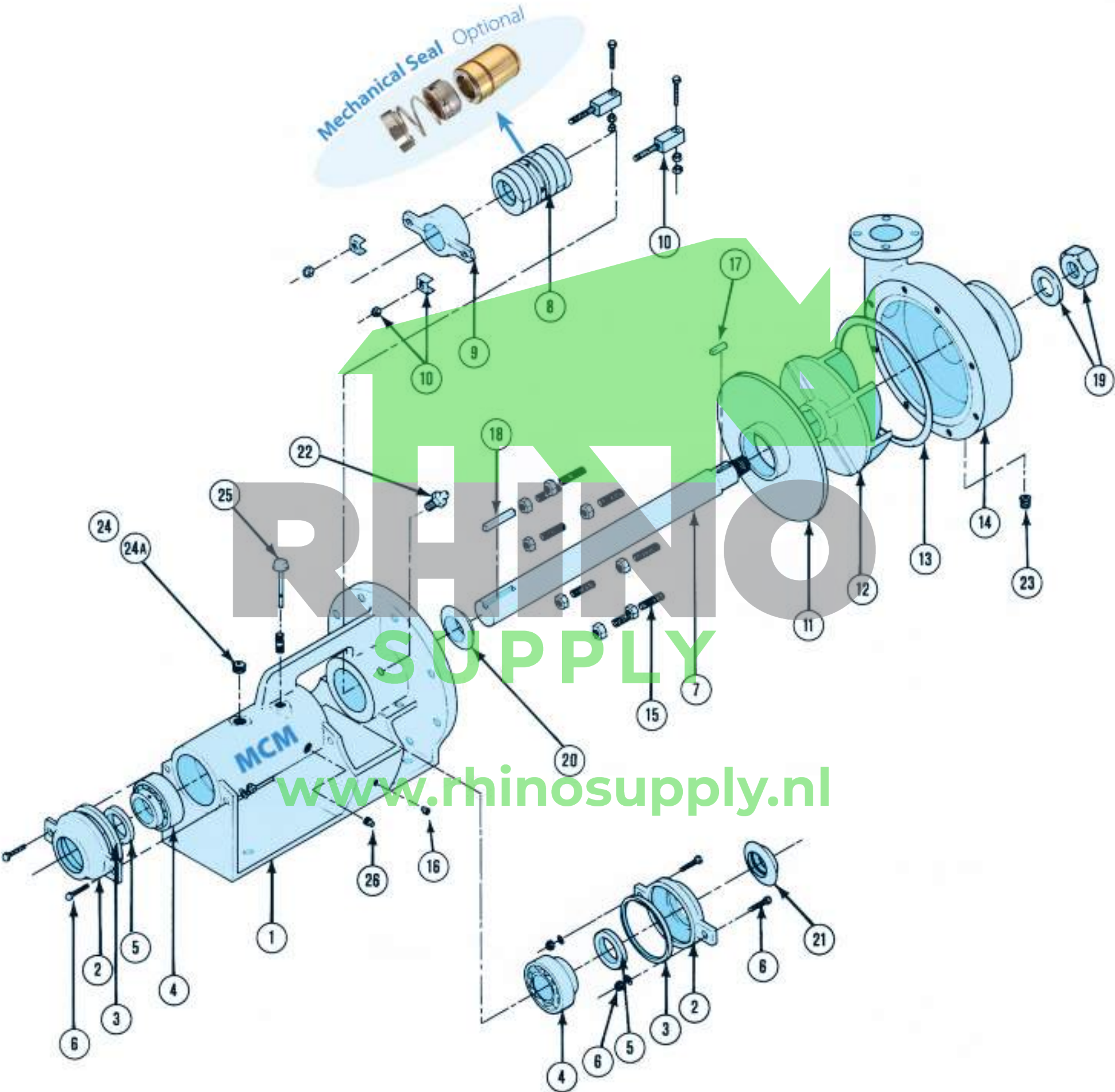

MCM Pumps... an Industry Leader!

118 PUMP SIZES

PUMP SIZE & ROTATION	MAX IMPELLER	MODEL NUMBER		
		CAST IRON	ALUMINUM BRONZE	ALUMINUM BRONZE FITTED
1x1½R	8½"	CP1811CRXXX	CP1811ARXXX	CP1811AFRXXX
1x1½L	8½"	CP1811CLXXX	CP1811ALXXX	CP1811AFLXXX
1½x2R	8½"	CP1812CRXXX	CP1812ARXXX	CP1812AFRXXX
1½x2L	8½"	CP1812CLXXX	CP1812ALXXX	CP1812AFLXXX
2x3R	8½"	CP1823CRXXX	CP1823ARXXX	CP1823AFRXXX
2x3L	8½"	CP1823CLXXX	CP1823ALXXX	CP1823AFLXXX
3x4R	8½"	CP1834CRXXX	CP1834ARXXX	CP1834AFRXXX

NOTE: 118 Series Pumps available in stainless steel on request.
Add /MS for pumps with Mechanical Seals.

118 PUMP PARTS LIST

Item No.	Part No.	Description	Qty. Req'd.	Approx. Wt.
1	P18PED	118 Pedestal	1	87.00
2	P18BC	118 Bearing Cap	2	2.50
3	P18BCG	118 Bearing Cap Gasket	2	.05
4	P18BA	118 Bearing Assembly	2	1.50
5	P18OGS	118 Oil & Grease Seal	2	.15
6	P18BCBA	118 Bearing Cap Bolt Assembly	4	.15
7	*	118 Shaft Assembly	1	6.00
8	*	118 Packing Assembly / Mechanical Seal	1	.50
9	P18PG	118 Packing Gland	1	1.50
10	P18GABA	118 Gland Adjustment Bolt Assembly	2	.50
11	*	118 Wear Plate	1	6.50
12	*	118 Impeller	1	*
13	P18HG	118 Housing Gasket	1	.10
14	*	118 Housing Assembly	1	*
15	P18HSN	118 Housing Stud W/ Nut	8	.25
16	P18DBDP	118 Drip Bowl Drain Plug	1	.25
17	P18IK3S	118 Impeller Key	1	.10
18	P18CK4S	118 Coupling Key	1	.25
19	P18LNA	118 Shaft Lock Nut Assembly	1	.25
20	P18SRO	118 Slinger Ring - Oil	1	.25
21	P18SRW	118 Slinger Ring - Water	1	.25
22	P18ZGF	118 Zert Grease Fitting	1	.10
23	P18HDP	118 Housing Drain Plug	1	.10
24	P18FBC	118 Filler Breather Cap	1	.25
24A	P18OVV	118 Oil Vent Valve	1	.05
25	P18DS	118 Dip Stick	1	.50
26	P18ODP	118 Oil Drain Plug	1	.05

*See Options

118 SERIES

Cast Iron or Aluminum Bronze PARTS OPTIONS

Item No.	Part No.	Description	Approx. Wt.
*7	P18SH316SS	118 Plain 316-SS Shaft Assembly	6.00
	P18SH416SS	118 Plain 416-SS Shaft Assembly	6.00
	P18SH416SC	118 416-SS Ceramic Coated Shaft Assembly	6.00
*8	P18PMSG	118 Graphite Packing Assembly	.50
	P18PMSK	118 King Packing Assembly	.50
	P18PMST	118 Teflon Packing Assembly	.50
	P18MSXX	118 Mechanical Seal	2.00
*11	P18WPC	118 Cast Iron Wear Plate	6.50
	P18WPA	118 Aluminum Bronze Wear Plate	6.50
*12	P18C11MRXXX	118 1x1½ Cast Iron Right Hand Impeller	7.50
	P18C11MLXXX	118 1 x 1½ Cast Iron Left Hand Impeller	7.50
	P18C12MRXXX	118 1½ x 2 Cast Iron Right Hand Impeller	8.00
	P18C12MLXXX	118 1½ x 2 Cast Iron Left Hand Impeller	8.00
	P18A12MRXXX	118 1½ x 2 Aluminum Bronze Right Hand Impeller	8.00
	P18A12MLXXX	118 1½ x 2 Aluminum Bronze Left Hand Impeller	8.00
	P18C23MRXXX	118 2 x 3 Cast Iron Right Hand Impeller	8.50
	P18C23MLXXX	118 2 x 3 Cast Iron Left Hand Impeller	8.50
	P18A23MRXXX	118 2 x 3 Aluminum Bronze Right Hand Impeller	8.50
	P18A23MLXXX	118 2 x 3 Aluminum Bronze Left Hand Impeller	8.50
	P18C34MRXXX	118 3 x 4 Cast Iron Right Hand Impeller	10.00
	P18A34MRXXX	118 3 x 4 Aluminum Bronze Right Hand Impeller	10.00
*14	P18C11HR	118 1 x 1½ Cast Iron Right Hand Housing Assembly	42.00
	P18C11HL	118 1 x 1½ Cast Iron Left Hand Housing Assembly	42.00
	P18C12HR	118 1½ x 2 Cast Iron Right Hand Housing Assembly	44.00
	P18C12HL	118 1½ x 2 Cast Iron Left Hand Housing Assembly	44.00
	P18A12HR	118 1½ x 2 Aluminum Bronze Right Hand Housing Assembly	44.00
	P18A12HL	118 1½ x 2 Aluminum Bronze Left Hand Housing Assembly	44.00
	P18C23HR	118 2 x 3 Cast Iron Right Hand Housing Assembly	54.00
	P18C23HL	118 2 x 3 Cast Iron Left Hand Housing Assembly	54.00
	P18A23HR	118 2 x 3 Aluminum Bronze Right Hand Housing Assembly	56.00
	P18A23HL	118 2 x 3 Aluminum Bronze Left Hand Housing Assembly	56.00
	P18C34HR	118 3 x 4 Cast Iron Right Hand Housing Assembly	72.00
	P18A34HR	118 3 x 4 Aluminum Bronze Right Hand Housing Assembly	72.00

*See Impeller Size Code On Page 8

Look and Compare...

We are your best Choice !!!

MCM Pedestal

MCM's Beefed-Up frame design is stronger and more rigid in all wear areas. It gives a larger work area to facilitate packing the pump, which cuts repacking time.

It also has a large pollution bowl for holding any fluid leakage and making a cleaner, safer operation.



MCM Bearings

MCM's *Heavy-Duty* bearings are well protected by spring type oil seals and a water slinger designed to keep fluid and dirt out of the bearing cavity. Eccentric locks are used so the shaft can be easily removed without special tools. This makes for easy adjustment of im-peller clearance.



MCM Housing

MCM's concentric housing design is available in right hand or left hand operation. It reduces turbulence within the pump to minimize cavitation, shaft deflection, and excessive wear. This results in a smoother operating and a longer running pump.



MCM Mechanical Seal (Optional)

MCM takes pride in carrying one of the finest mechanical seals on the market.



MCM Impeller

MCM's semi open impeller is designed to handle water or heavy slurries with equal efficiency. The pronounced back vanes of the impeller are designed to reduce the pressure on the stuffing box, thus, increasing the life of the packing and decreasing the wear on the shaft.



MCM Graphite Packing

MCM Graphite consists of five graphite rings and one lantern ring.



MCM Shaft

The MCM 118 shaft is manufactured from the highest quality 416 stainless steel. Designed to transmit maximum torque with minimum shaft deflection.



MCM Wear Plate

MCM's replaceable wear plate protects the pedestal from wear and corrosion caused by fluids being pumped, therefore, extending the life of the pump.



**ISO
9001:2000
CERTIFIED**

118 SERIES

Dimensional Outline

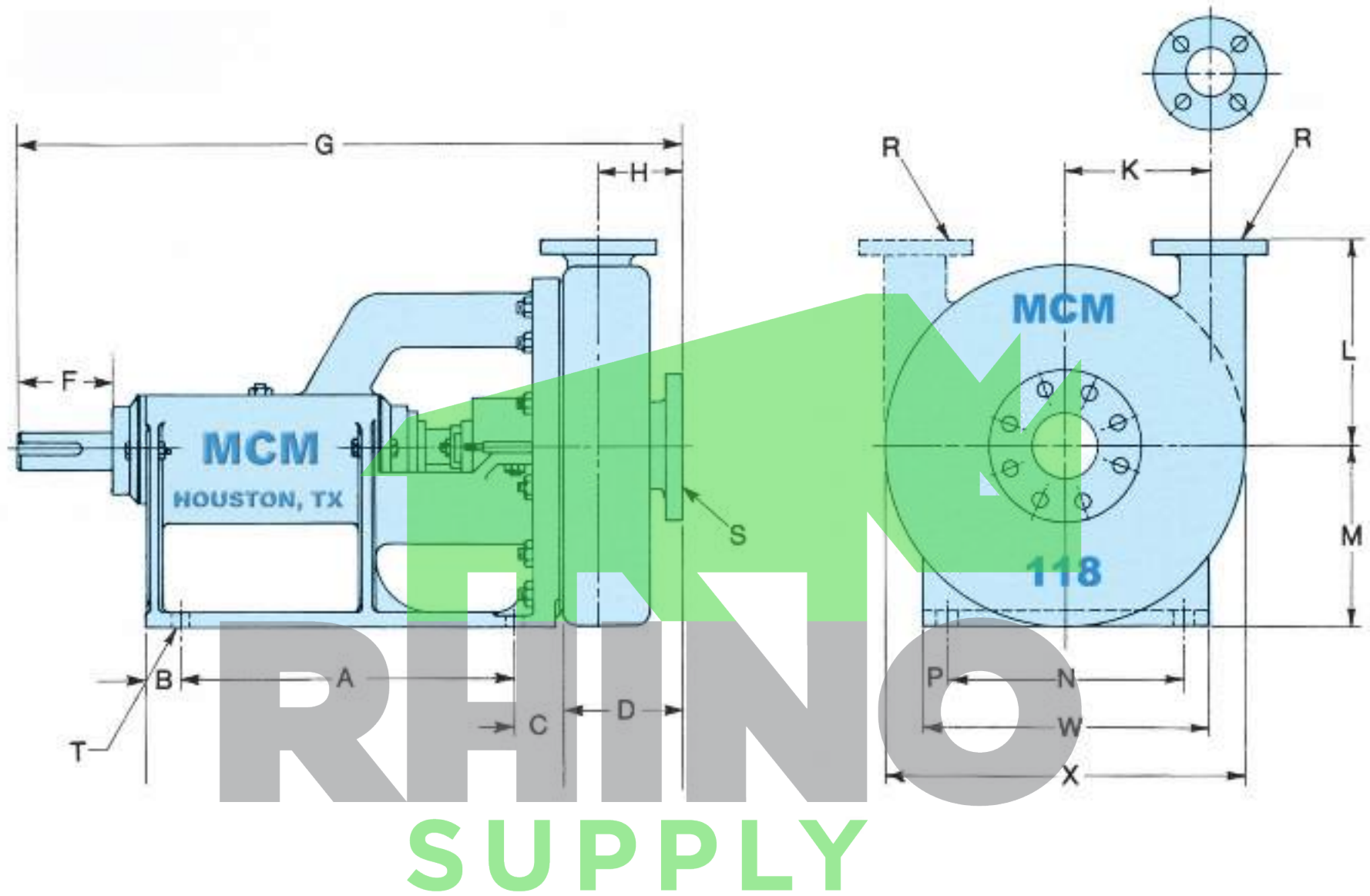

PEDESTAL, HOUSING, & INSTALLATION DIMENSIONS

PUMP SIZE	A	B	C	D	F	G	H	K	L	M	N	P	R	S	T	W	X
1x1½ R & L	13	1 ⁷ / ₁₆	2 ³ / ₈	4 ¹ / ₄	3 ⁵ / ₁₆	26 ¹ / ₄	3 ¹ / ₈	4 ⁷ / ₈	7 ¹ / ₂	7	4 ¹ / ₄	7 ⁷ / ₈	1	1 ¹ / ₂	(4)-1 ¹ / ₁₆	6	12
1½x2 R & L	13	1 ⁷ / ₁₆	2 ³ / ₈	5	3 ⁵ / ₁₆	26 ³ / ₄	3 ¹ / ₂	4 ⁵ / ₈	7 ¹¹ / ₁₆	7	4 ¹ / ₄	7 ⁷ / ₈	1 ¹ / ₂	2	(4)-1 ¹ / ₁₆	6	12
2x3 R & L	13	1 ⁷ / ₁₆	2 ³ / ₈	5 ¹ / ₂	3 ⁵ / ₁₆	27	3 ³ / ₄	5 ¹ / ₂	7 ³ / ₄	7	4 ¹ / ₄	7 ⁷ / ₈	2	3	(4)-1 ¹ / ₁₆	6	12
3x4 R	13	1 ⁷ / ₁₆	2 ³ / ₈	6 ⁵ / ₈	3 ⁵ / ₁₆	28 ¹ / ₂	4 ¹ / ₄	5	8	7	4 ¹ / ₄	7 ⁷ / ₈	3	4	(4)-1 ¹ / ₁₆	6	12 ³ / ₄

FLANGE SIZES

Pump Size	Pump Type (Shaft Dia.)	Discharge Pipe		Suction Pipe	
		Size	Drilling	Size	Drilling
1 x 1½	1 ¹ / ₈	1	4 Holes 5/8 Dia. 3 3/8 B.C.	1½	4 Holes 5/8 Dia. 3 7/8 B.C.
1½ x 2	1 ¹ / ₈	1½	4 Holes 5/8 Dia. 3 7/8 B.C.	2	4 Holes 3/4 Dia. 4 3/4 B.C.
2 x 3	1 ¹ / ₈	2	4 Holes 3/4 Dia. 4 3/4 B.C.	3	4 Holes 3/4 Dia. 6 B.C.
3 x 4	1 ¹ / ₈	3	4 Holes 3/4 Dia. 6 B.C.	4	8 Holes 3/4 Dia. 7 1/2 B.C.

118 SERIES

Performance Curves

1 x 1 1/2 1150 RPM

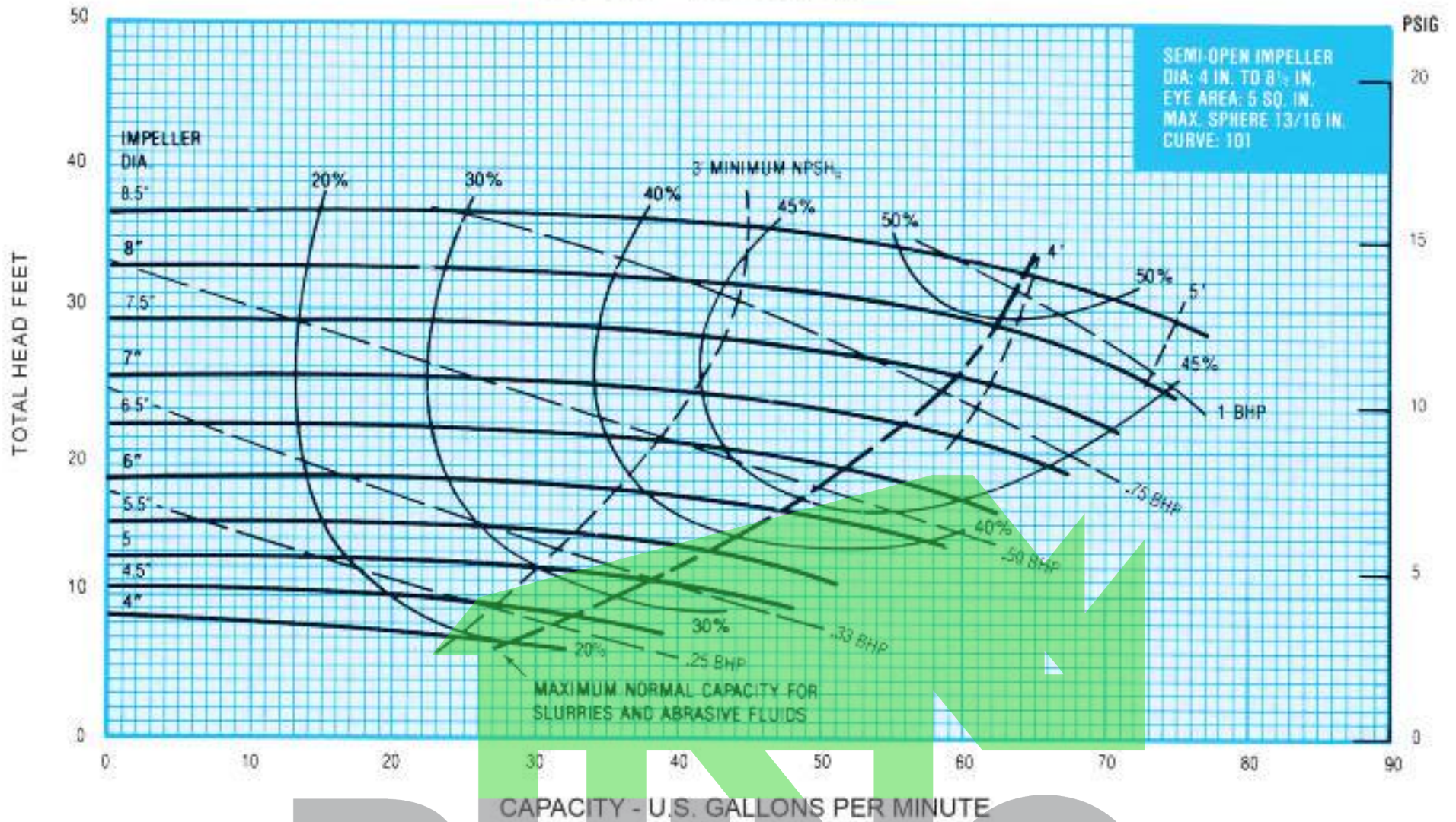

RHINO

1 x 1 1/2 1750 RPM

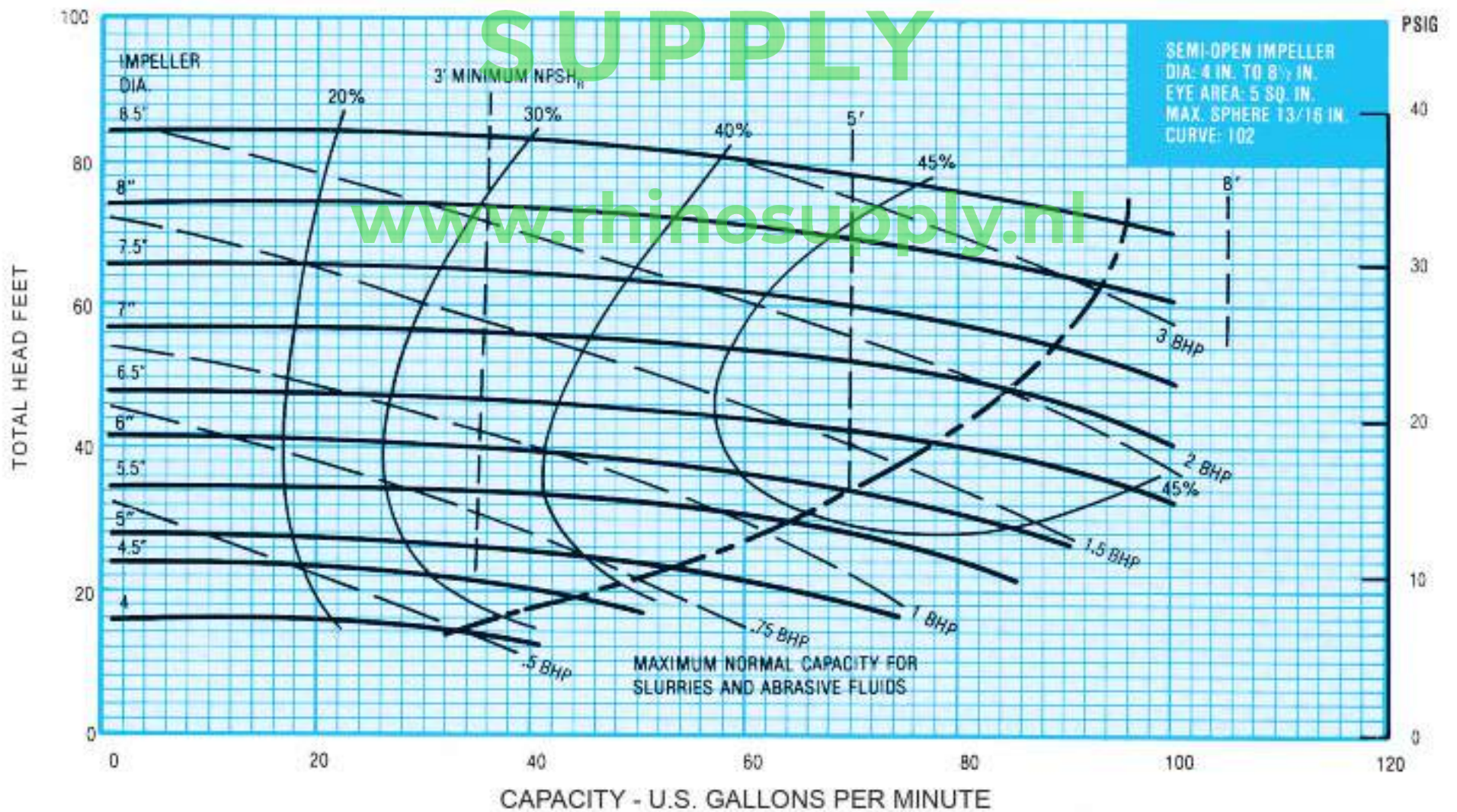

Curves show performance with clear water. If specific gravity is other than 1.0, curve HP must be corrected.

1 x 1½ 3500 RPM

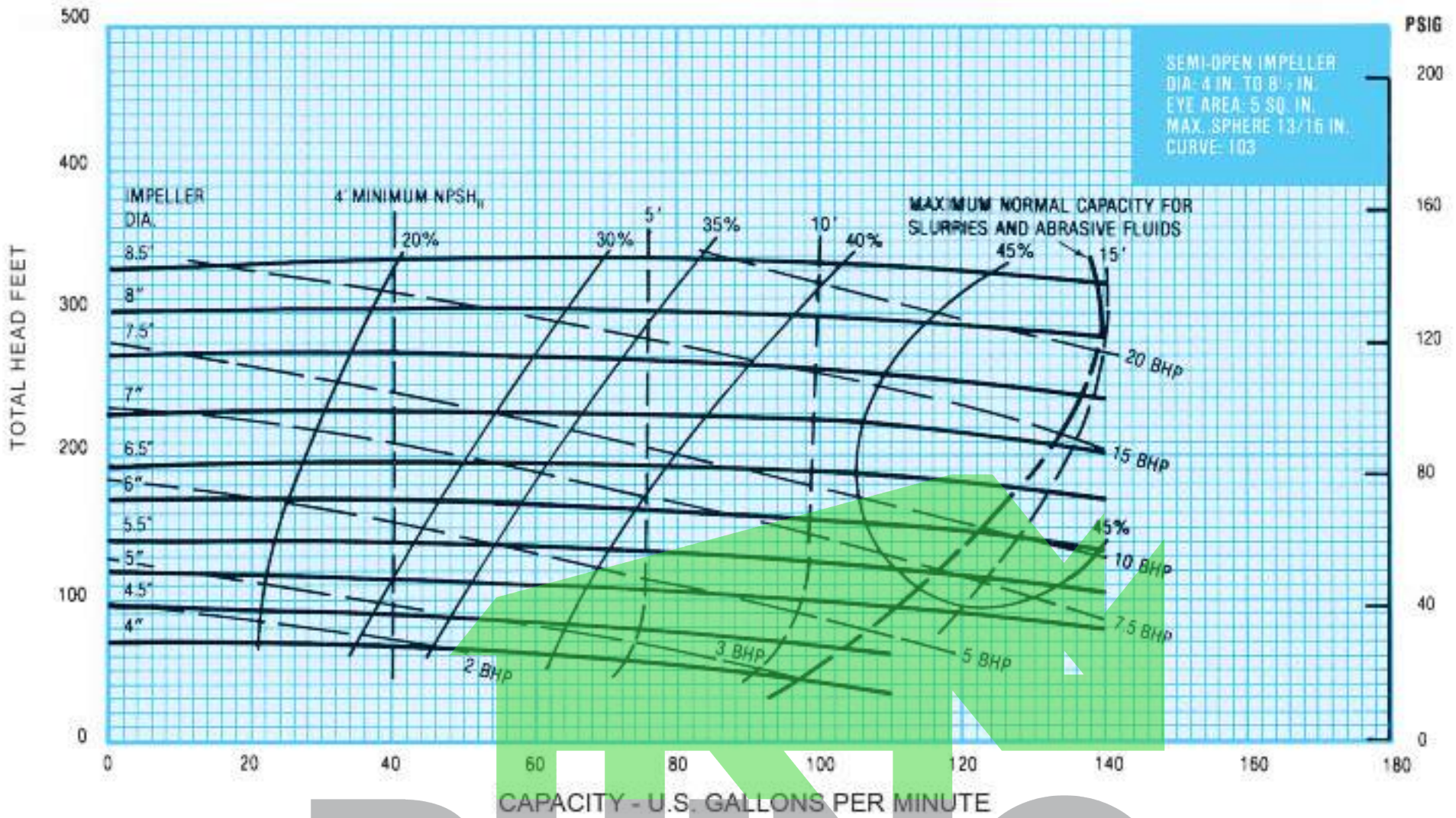

RHINO
1 x 1½ 1000-3600 RPM

SUPPLY

www.rhinosupply.nl

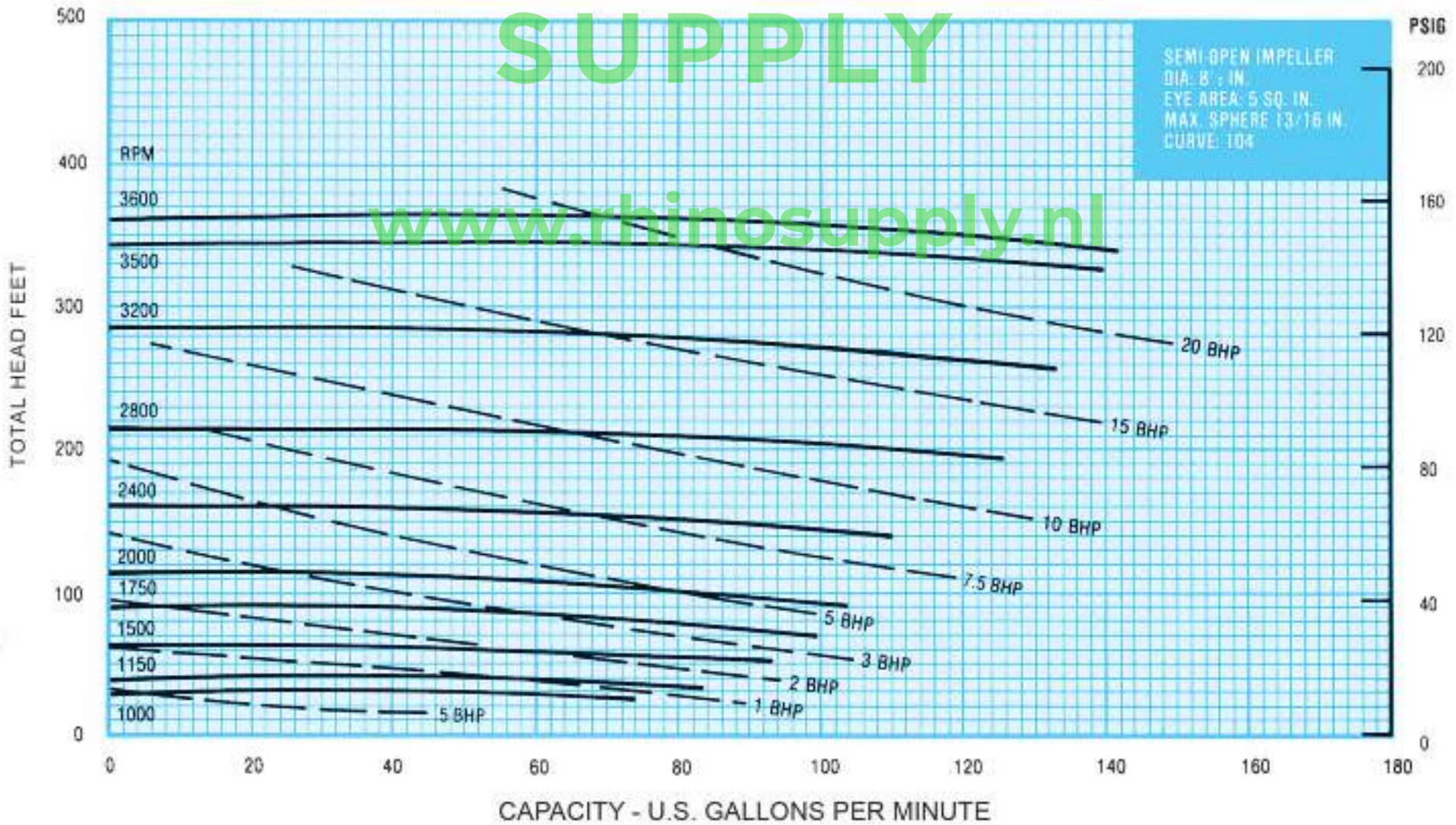

Curves show performance with clear water. If specific gravity is other than 1.0, curve HP must be corrected.

118 SERIES



1 1/2 x 2 1150 RPM

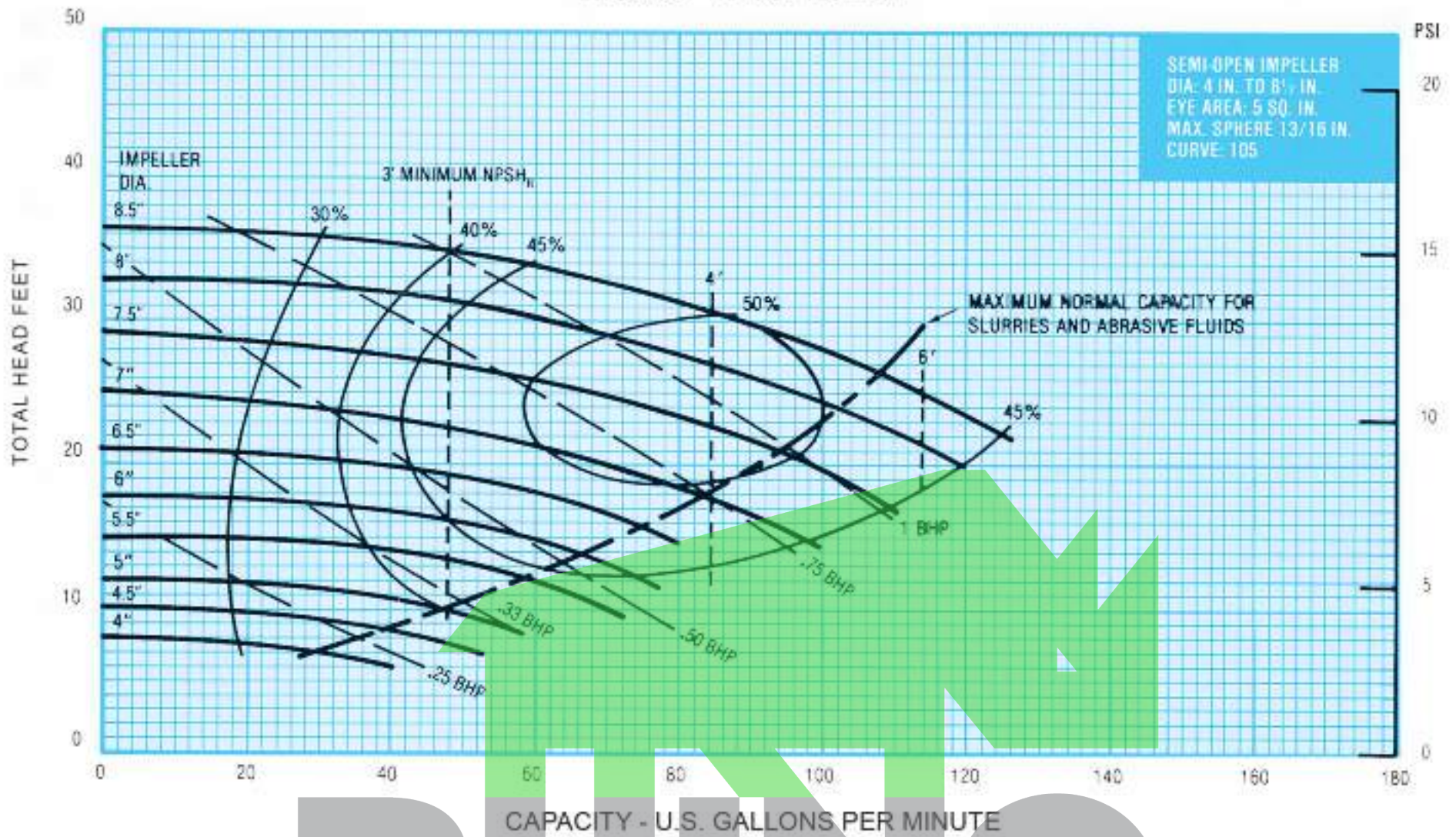

RHINO

1 1/2 x 2 1750 RPM

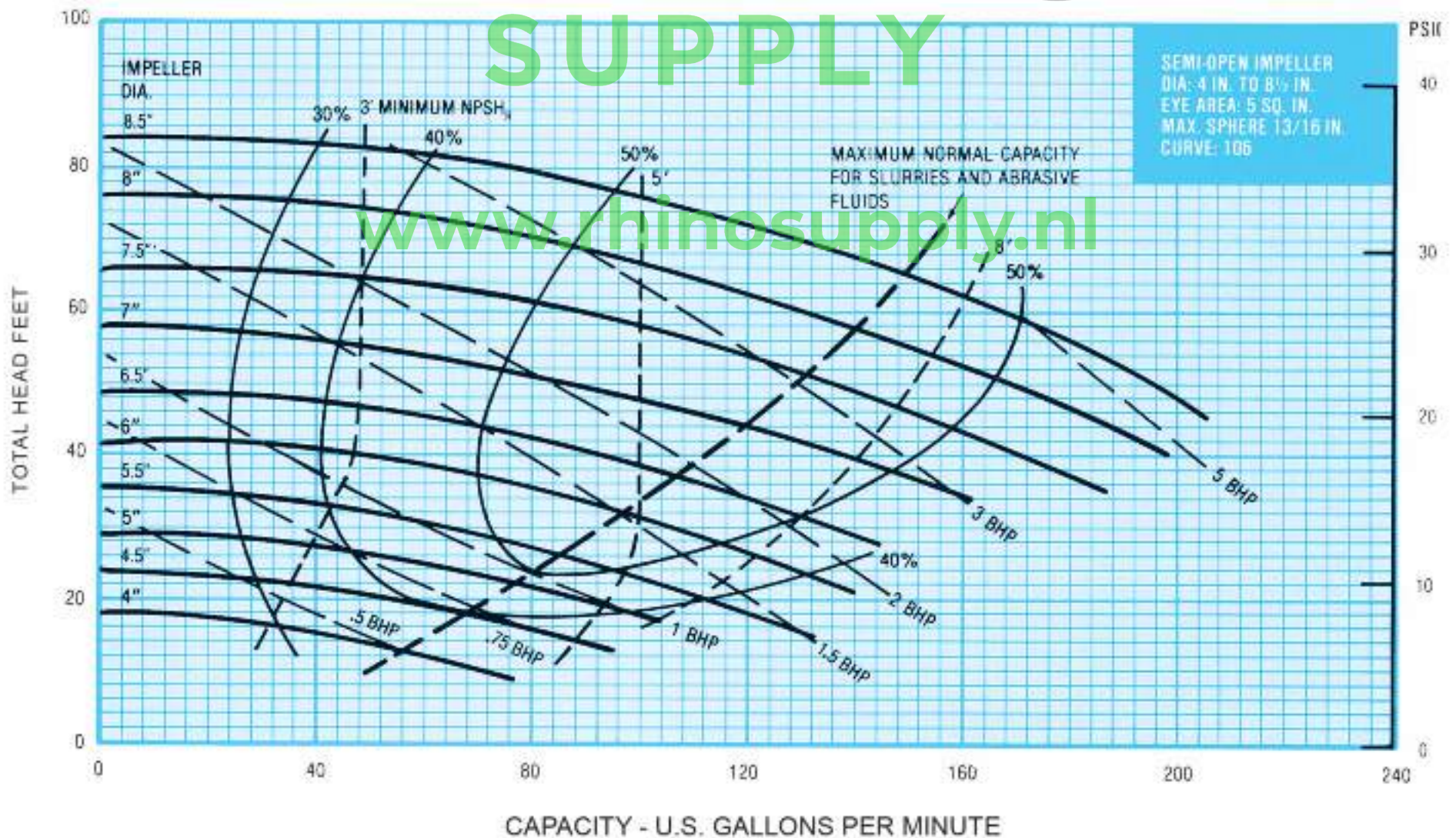

Curves show performance with clear water. If specific gravity is other than 1.0, curve HP must be corrected.

1½ x 2 3500 RPM

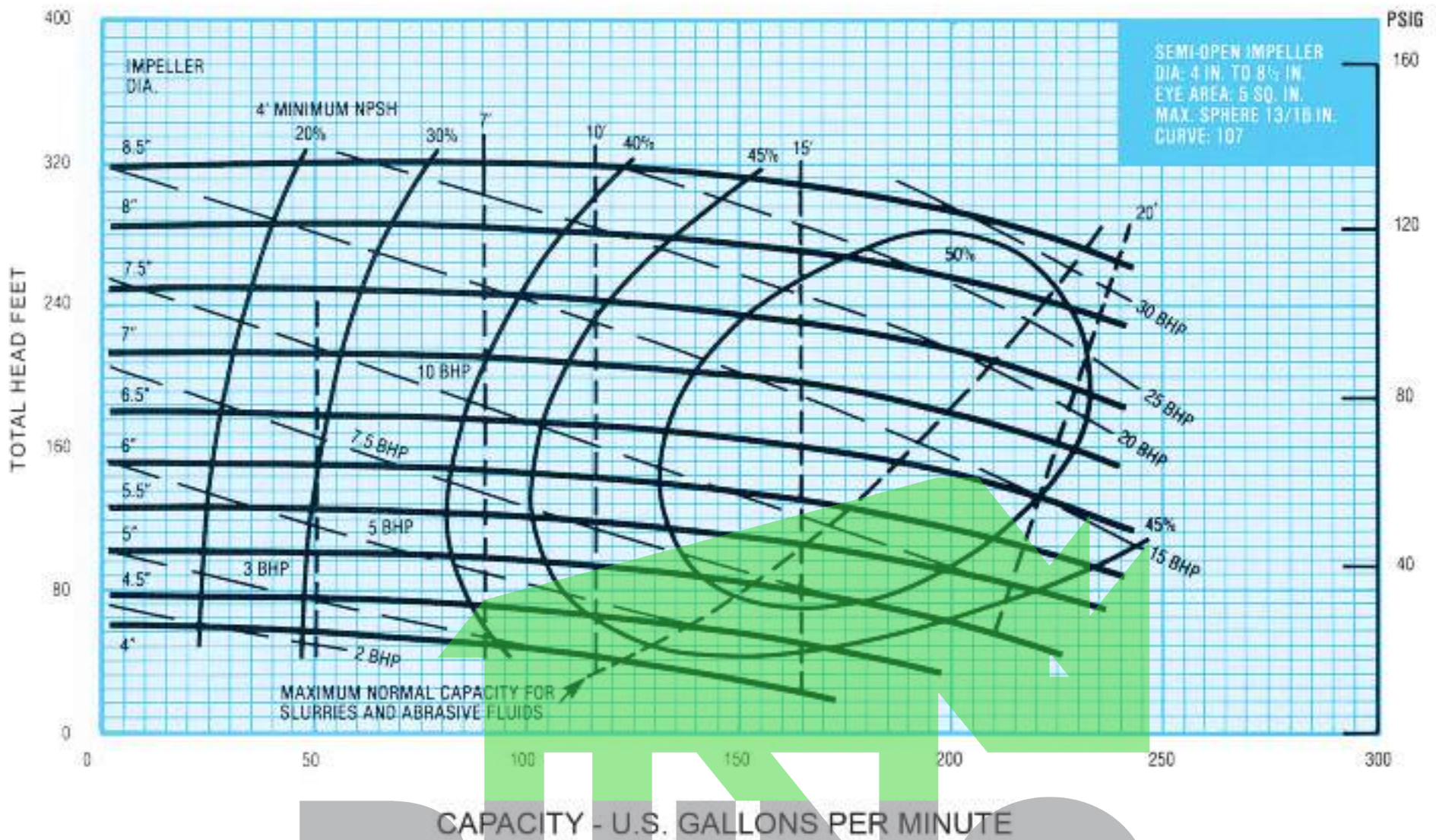

RHINO

1½ x 2 1000 TO 3600 RPM

SUPPLY

www.rhinosupply.nl



Curves show performance with clear water. If specific gravity is other than 1.0, curve HP must be corrected.

118 SERIES



2 x 3 1150 RPM

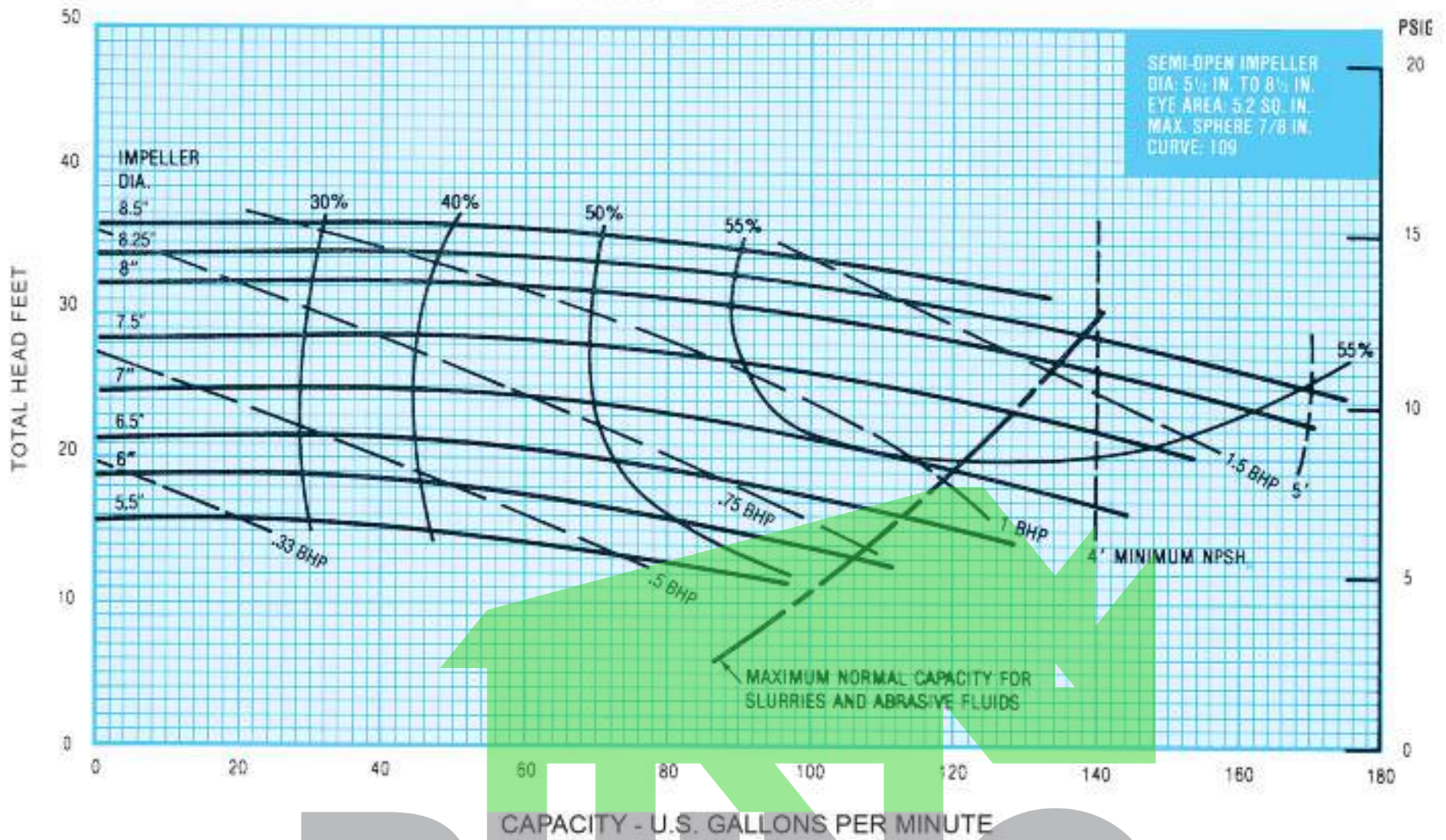

RHINO

2 x 3 1750 RPM

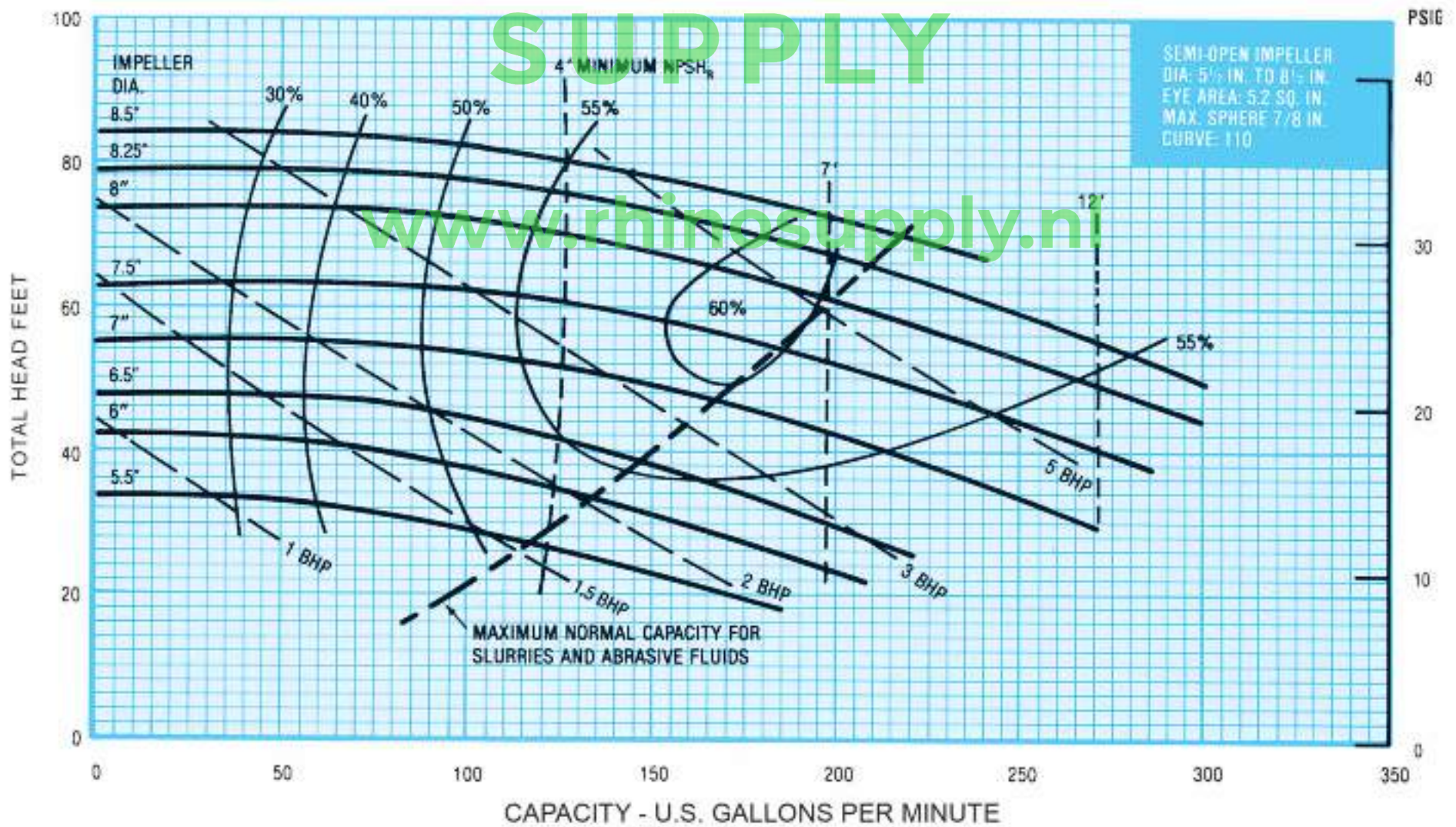

Curves show performance with clear water. If specific gravity is other than 1.0, curve HP must be corrected.

2 x 3 3500 RPM

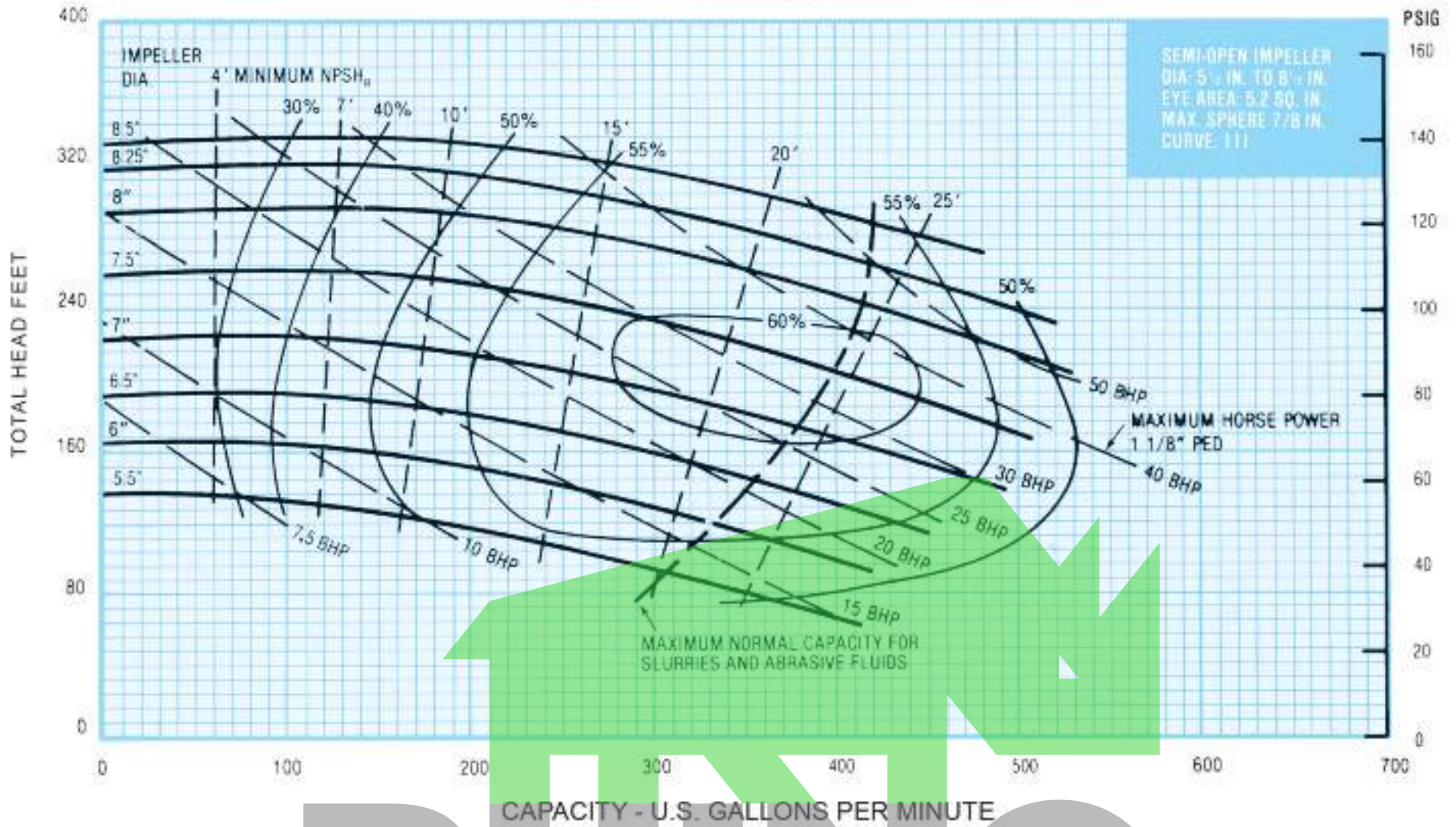

RHINO

2 x 3 1000-2800 RPM

SUPPLY

www.rhinosupply.nl

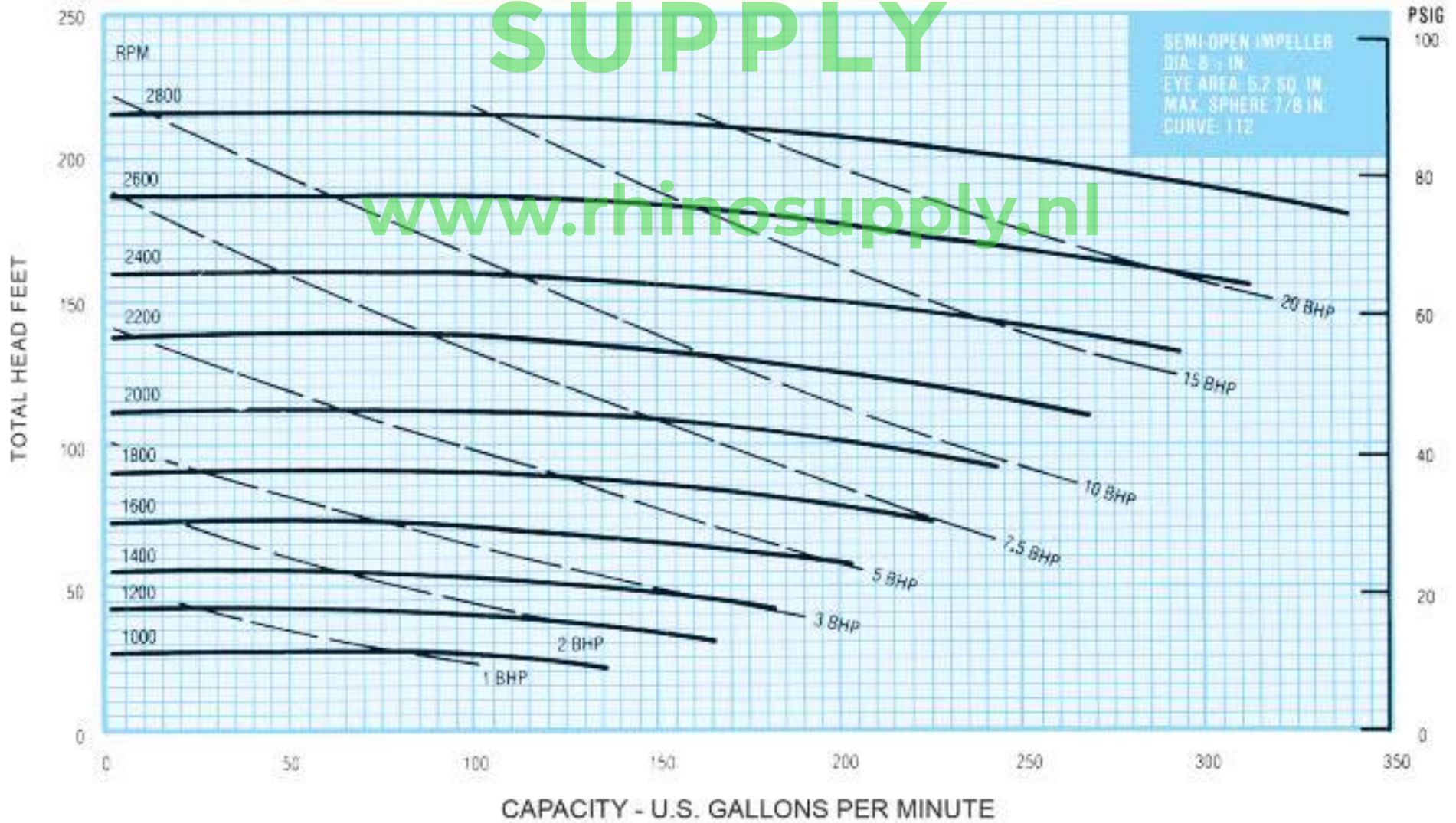

Curves show performance with clear water. If specific gravity is other than 1.0, curve HP must be corrected.

118 SERIES



3 x 4 1150 RPM

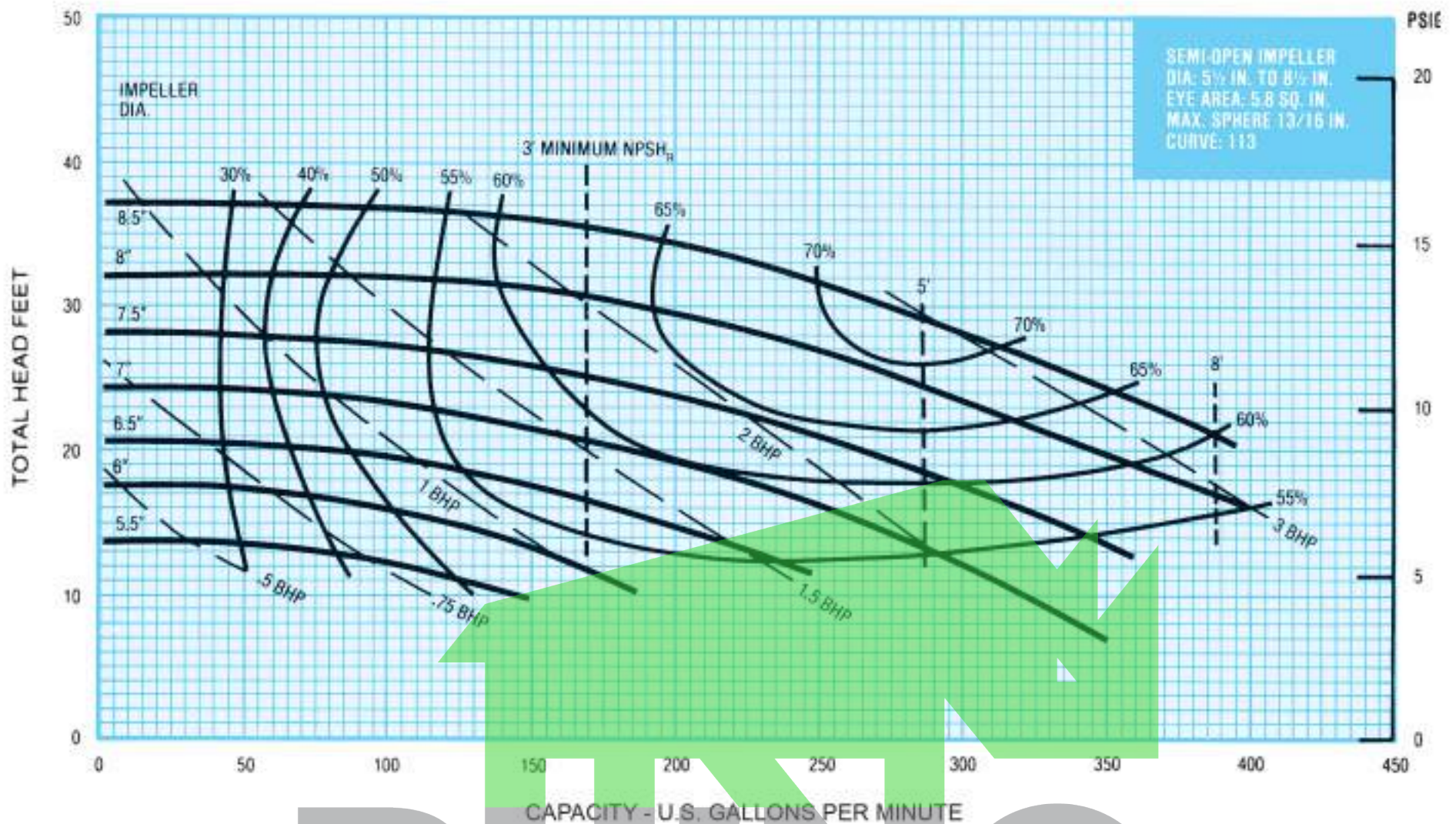

RHINO

3 x 4 1750 RPM

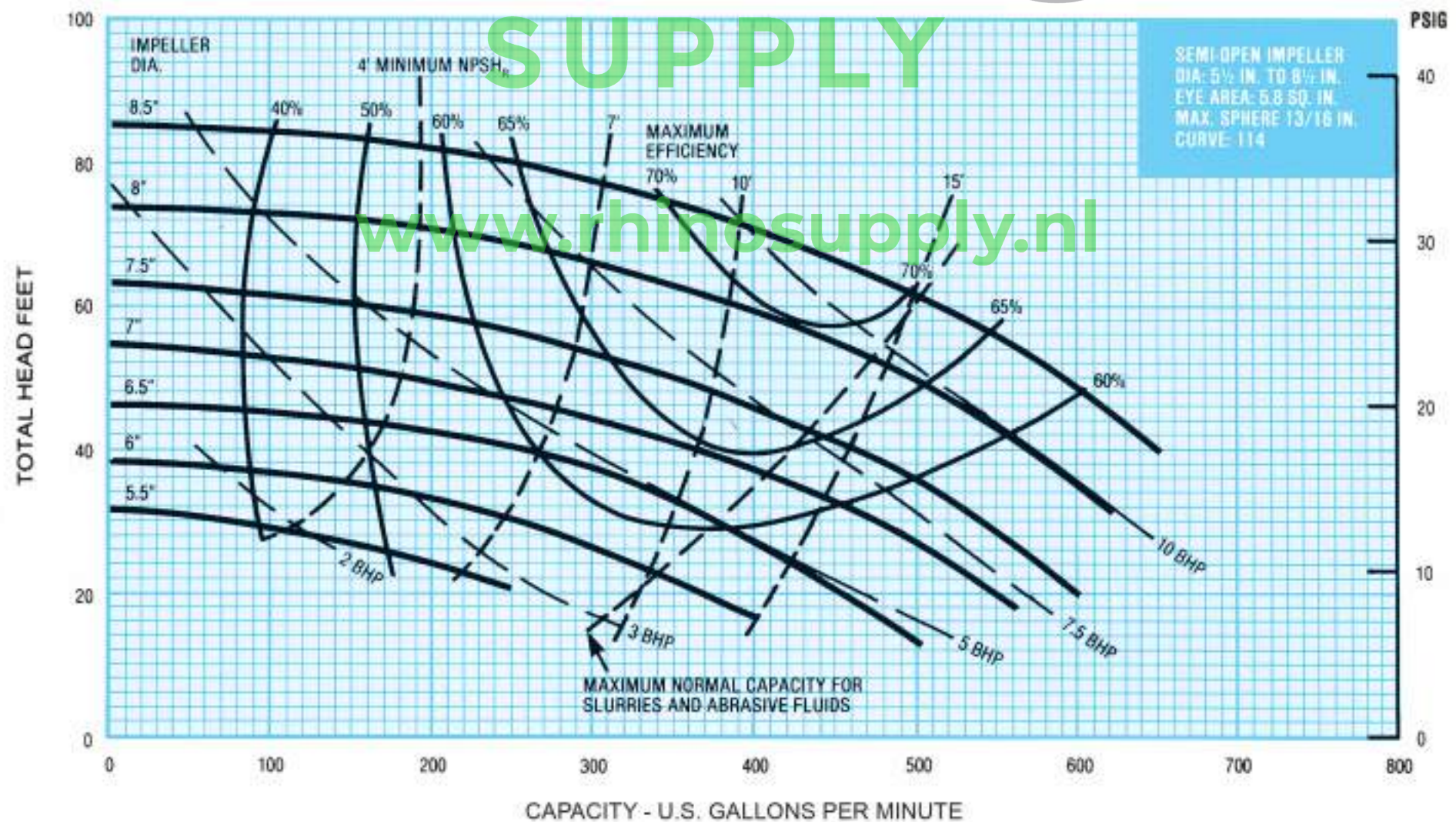

Curves show performance with clear water. If specific gravity is other than 1.0, curve HP must be corrected.

118 SERIES

3 x 4 3500 RPM

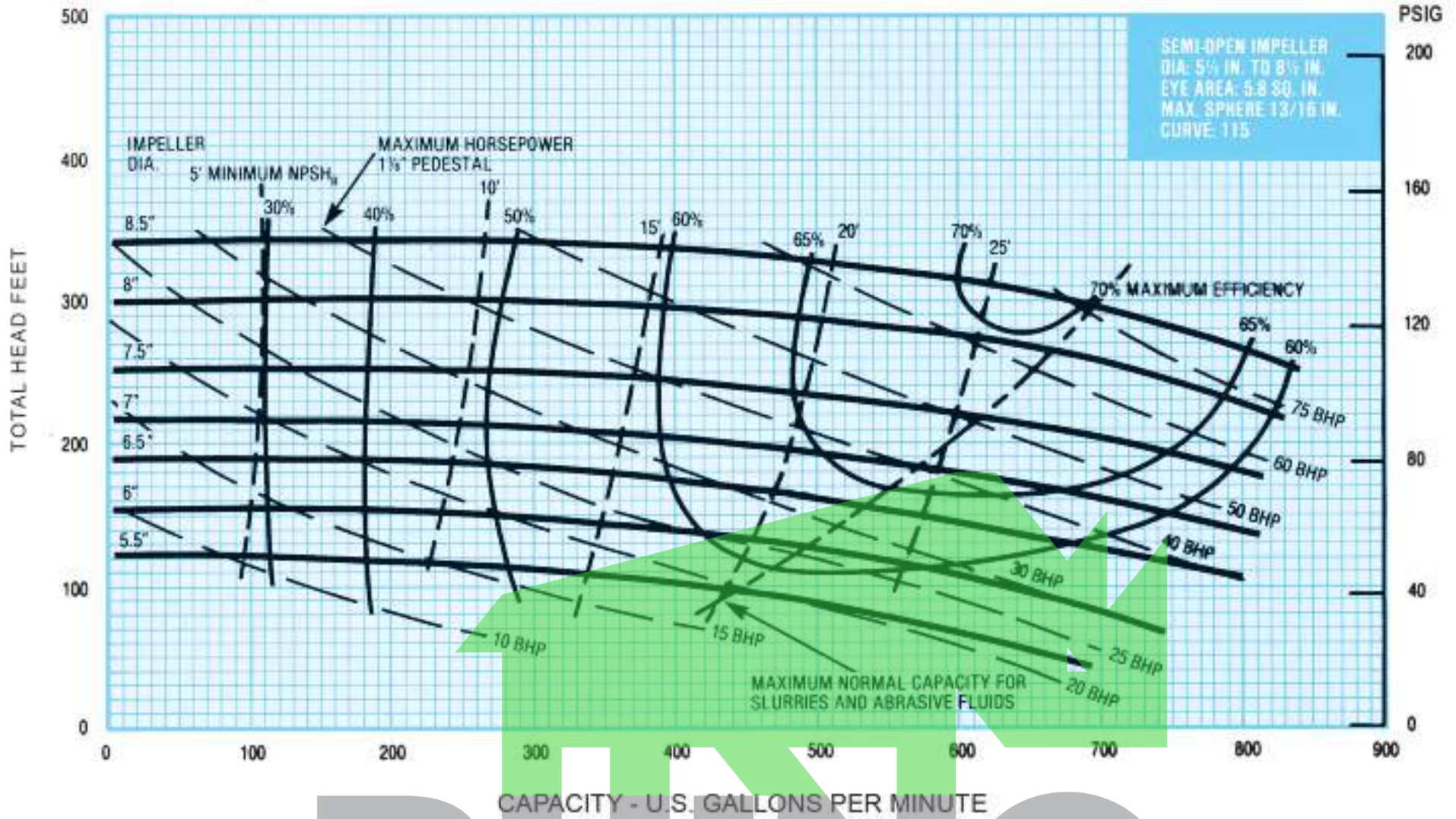

RHINO

3 x 4 800-3600 RPM

SUPPLY

www.rhinosupply.nl

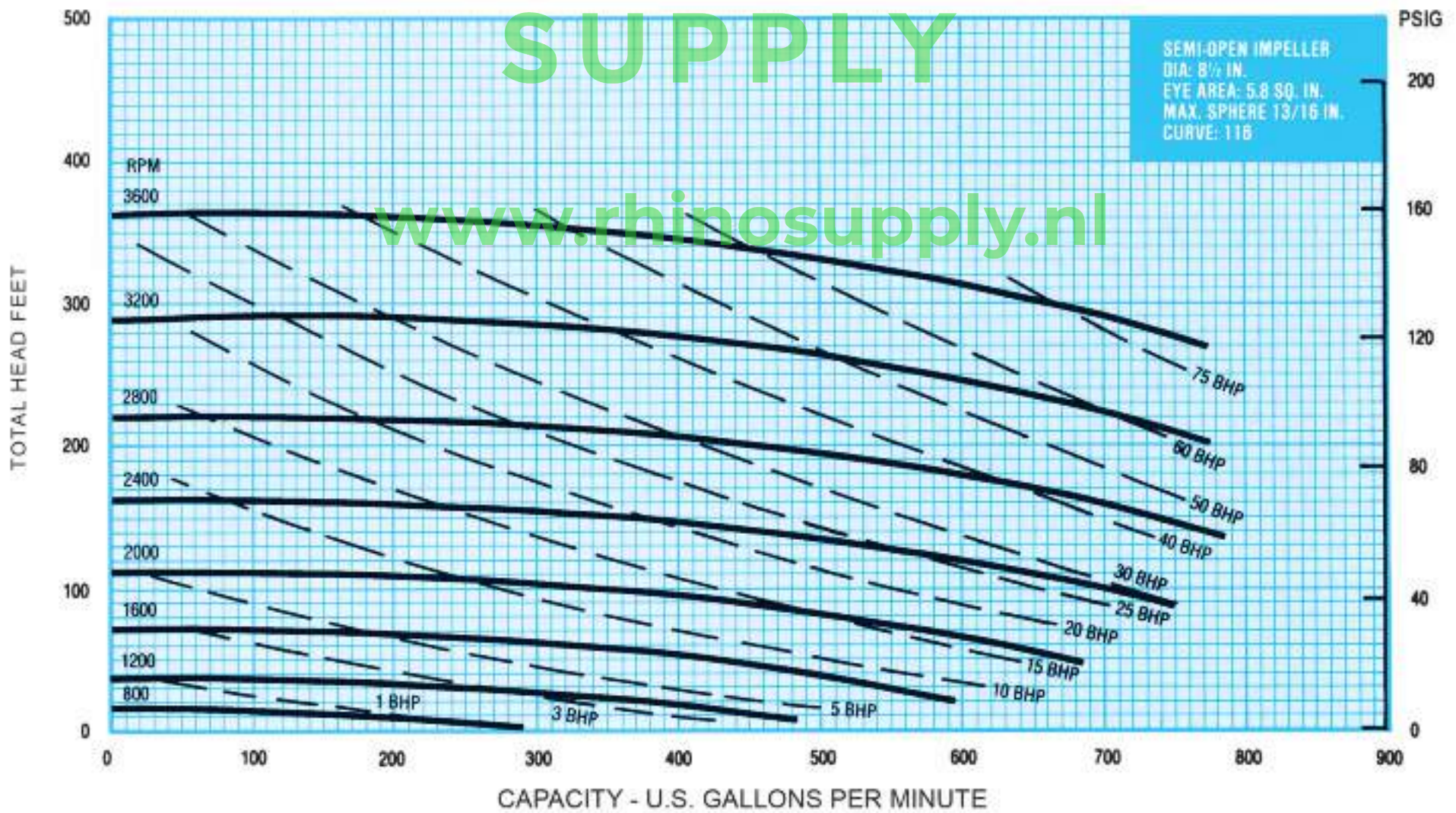

Curves show performance with clear water. If specific gravity is other than 1.0, curve HP must be corrected.

MCM Pedestal

MCM's Beefed-Up frame design is stronger and more rigid in all wear areas. It gives a larger work area to facilitate packing the pump, which cuts repacking time.

It also has a large pollution bowl for holding any fluid leakage and making a cleaner, safer operation.



MCM Bearings

MCM's *Heavy-Duty* bearings are well protected by spring type oil seals and a water slinger designed to keep fluid and dirt out of the bearing cavity. Eccentric locks are used so the shaft can be easily removed without special tools. This makes for easy adjustment of impeller clearance.



MCM Housing & Face

MCM's two piece concentric housing design gives the versatility of either right hand or left hand operation, plus easy access to the impeller. It reduces turbulence within the pump to minimize cavitation, shaft deflection, and excessive wear. This results in a smoother operating and a longer running pump.

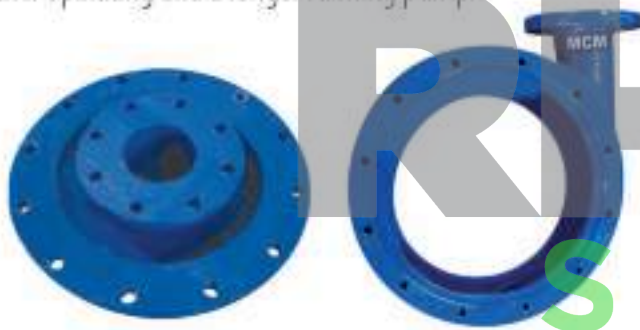

MCM Mechanical Seal (Optional)

MCM takes pride in carrying one of the finest mechanical seals on the market.



MCM Graphite Packing

MCM Graphite consists of five graphite rings and one lantern ring.



MCM Impeller

MCM's semi open impeller is designed to handle water or heavy slurries with equal efficiency. The pronounced back vanes of the impeller are designed to reduce the pressure on the stuffing box, thus, increasing the life of the packing and decreasing the wear on the shaft.



www.rhinosupply.nl

MCM Shaft

The MCM 178 shaft is manufactured from the highest quality 416 stainless steel. Designed to transmit maximum torque with minimum shaft deflection.



MCM Wear Plate

MCM's replaceable wear plate protects the pedestal from wear and corrosion caused by fluids being pumped, therefore, extending the life of the pump.



178 SERIES *Parts Diagram*

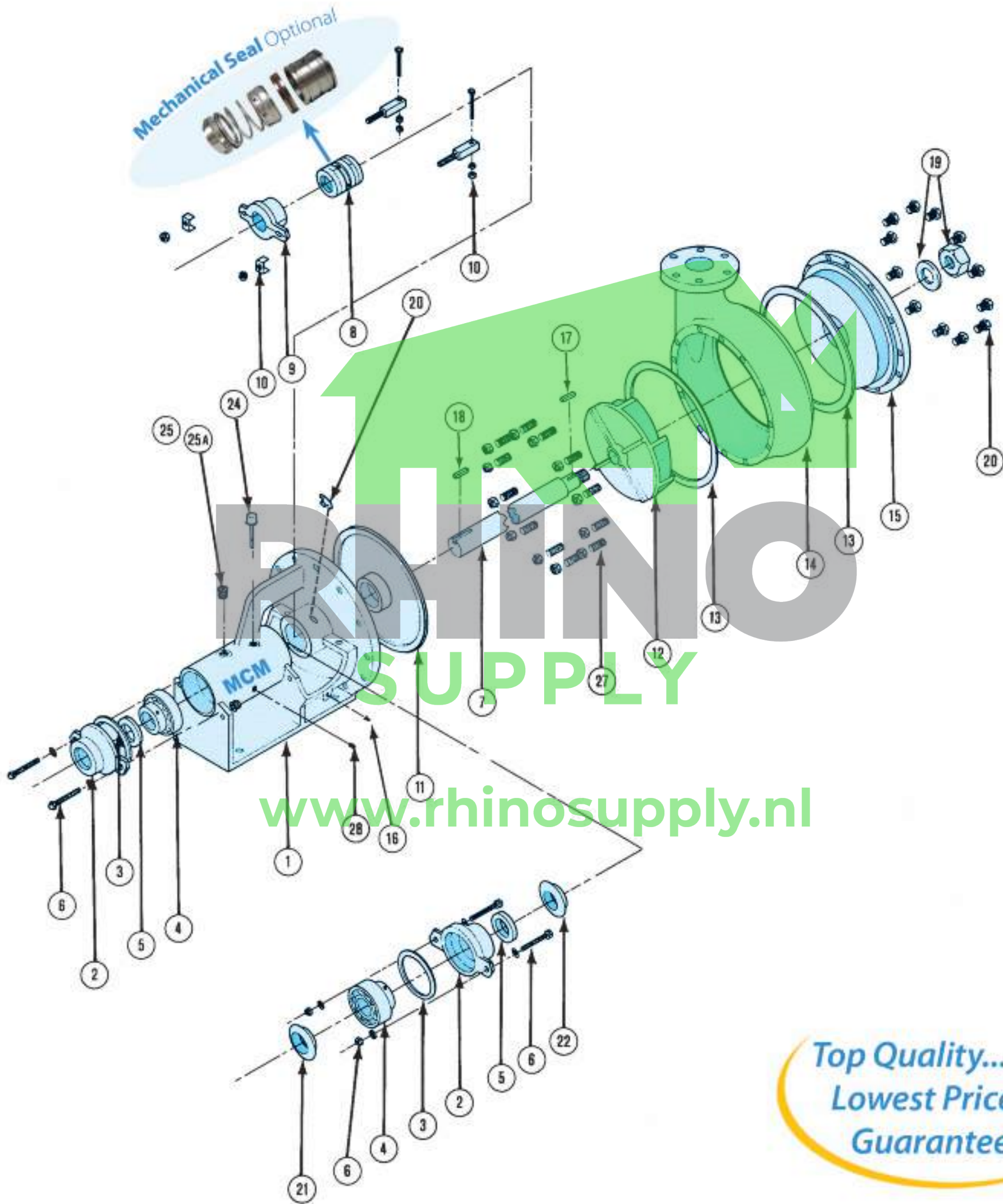

Call: (713) 541.2020 Fax: (713) 541.9090 • Toll Free: 1.800.255.6263



Leading the way

178 SERIES

178 PUMP SIZES

PUMP SIZE & ROTATION	MAX IMPELLER	MODEL NUMBER			
		316-SS	DUCTILE IRON	ALUMINUM BRONZE FITTED	ALUMINUM BRONZE
2x3R	13"	CP7823SRXXX	CP7823DRXXX	CP7823AFRXXX	CP7823ARXXX
2x3L	13"	CP7823SLXXX	CP7823DLXXX	CP7823AFLXXX	CP7823ALXXX
3x4R	13"	CP7834SRXXX	CP7834DRXXX	CP7834AFRXXX	CP7834ARXXX
3x4L	13"	CP7834SLXXX	CP7834DLXXX	CP7834AFLXXX	CP7834ALXXX
4x5R	12"	CP7845SRXXX	CP7845DRXXX	CP7845AFRXXX	CP7845ARXXX
4x5L	12"	CP7845SLXXX	CP7845DLXXX	CP7845AFLXXX	CP7845ALXXX
5x6R	12"	CP7856SRXXX	CP7856DRXXX	CP7856AFRXXX	CP7856ARXXX
5x6L	12"	CP7856SLXXX	CP7856DLXXX	CP7856AFLXXX	CP7856ALXXX
6x8R	13"	CP7868SRXXX	CP7868DRXXX	CP7868AFRXXX	CP7868ARXXX
6x8L	13"	CP7868SLXXX	CP7868DLXXX	CP7868AFLXXX	CP7868ALXXX

NOTE: 178 Series Pumps available in stainless steel on request.
Add / MS for pumps with Mechanical Seals.

178 PUMP PARTS LIST

Item No.	Part No.	Description	Qty. Req'd.	Approx. Wt.
1	P78PED	178 Pedestal	1	210.00
2	P78BC	178 Bearing Cap	2	5.00
3	P78BCG	178 Bearing Cap Gasket	2	.10
4	P78BA	178 Bearing Assembly	2	4.00
5	P78OGS	178 Oil & Grease Seal	2	.25
6	P78BCBA	178 Bearing Cap Bolt Assembly	4	.25
7	*	178 Shaft Assembly	1	25.00
8	*	178 Packing Assembly / Mechanical Seal	1	.50
9	P78PG	178 Packing Gland	1	1.75
10	P78GABA	178 Gland Adjustment Bolt Assembly	2	.75
11	*	178 Wear Plate	1	15.00
12	*	178 Impeller	1	*
13	P78HG	178 Housing Gasket	2	.10
14	*	178 Housing	1	*
15	*	178 Housing Face	1	*
16	P78DBDP	178 Drip Bowl Drain Plug	1	.25
17	P78IK-56	178 Impeller Key (2x3 thru 5x6)	1	.10
17A	P78IK-68	178 Impeller Key (6x8 only)	1	.10
18	P78CK	178 Coupling Key	1	.25
19	P78LNA	178 Lock Nut Assembly	1	.05
20	P78ZGF	178 Zert Grease Fitting	1	.10
21	P78SRO	178 Slinger Ring - Oil	1	.25
22	P78SRW	178 Slinger Ring - Water	1	.25
23	P78HDP	178 Housing Drain Plug	1	.25
24	P78DS	178 Dip Stick	1	.75
25	P78FBC	178 Filler Breather Cap	1	.50
25A	P78OVV	178 Oil Vent Valve	1	.05
26	P78HFCS	178 Housing Face Cap Screw	12	.25
27	P78HSN	178 Housing Stud W/ Nut	12	.50
28	P78ODP	178 Oil Drain Plug	1	.05

*See Options On Page 25

178 PUMP PARTS OPTIONS

Item No.	Part No.	Description	Approx. Wt.
*7	P78SH416SC56	178 416-SS Ceramic Coated Shaft F/ 2 x 3 Thru 5 x 6	25.00
	P78SH416SC68	178 416-SS Ceramic Coated Shaft F/ 6 x 8 (Only)	25.00
	P78SH316SS56	178 316-SS Shaft F/ 2 x 3 Thru 5 x 6	25.00
	P78SH316SS68	178 316-SS Shaft F/ 6 x 8 (Only)	25.00
	P78SH416SS56	178 416-SS Shaft F/ 2 x 3 Thru 5 x 6	25.00
	P78SH416SS68	178 416-SS Shaft F/ 6 x 8 (Only)	25.00
*8	P78PMSG	178 Graphite Packing Assembly	.50
	P78PMSK	178 King Packing Assembly	.50
	P78PMST	178 Teflon Packing Assembly	.50
	P78MSXX	178 Mechanical Seal	3.50
*11	P78WPS	178 316-SS Wear Plate	15.00
	P78WPD	178 Ductile Iron Wear Plate	15.00
	P78WPA	178 Aluminum Bronze Wear Plate	15.00
*12	P78S23MRXXX	178 2 x 3 316-SS Right Hand Impeller	23.00
	P78S23MLXXX	178 2 x 3 316-SS Left Hand Impeller	23.00
	P78D23MRXXX	178 2 x 3 Ductile Iron Right Hand Impeller	23.00
	P78D23MLXXX	178 2 x 3 Ductile Iron Left Hand Impeller	23.00
	P78A23MRXXX	178 2 x 3 Aluminum Bronze Right Hand Impeller	23.00
	P78A23MLXXX	178 2 x 3 Aluminum Bronze Left Hand Impeller	23.00
	P78S34MRXXX	178 3 x 4 316-SS Right Hand Impeller	25.00
	P78S34MLXXX	178 3 x 4 316-SS Left Hand Impeller	25.00
	P78D34MRXXX	178 3 x 4 Ductile Iron Right Hand Impeller	25.00
	P78D34MLXXX	178 3 x 4 Ductile Iron Left Hand Impeller	25.00
	P78A34MRXXX	178 3 x 4 Aluminum Bronze Right Hand Impeller	25.00
	P78A34MLXXX	178 3 x 4 Aluminum Bronze Left Hand Impeller	25.00
	P78S45MRXXX	178 4 x 5 316-SS Right Hand Impeller	32.00
	P78S45MLXXX	178 4 x 5 316-SS Left Hand Impeller	32.00
	P78D45MRXXX	178 4 x 5 Ductile Iron Right Hand Impeller	32.00
	P78D45MLXXX	178 4 x 5 Ductile Iron Left Hand Impeller	32.00
	P78A45MRXXX	178 4 x 5 Aluminum Bronze Right Hand Impeller	32.00
	P78A45MLXXX	178 4 x 5 Aluminum Bronze Left Hand Impeller	32.00
	P78S56MRXXX	178 5 x 6 316-SS Right Hand Impeller	35.00
	P78S56MLXXX	178 5 x 6 316-SS Left Hand Impeller	35.00
	P78D56MRXXX	178 5 x 6 Ductile Iron Right Hand Impeller	35.00
	P78D56MLXXX	178 5 x 6 Ductile Iron Left Hand Impeller	35.00
	P78A56MRXXX	178 5 x 6 Aluminum Bronze Right Hand Impeller	35.00
	P78A56MLXXX	178 5 x 6 Aluminum Bronze Left Hand Impeller	35.00
	P78S68MRXXX	178 6 x 8 316-SS Right Hand Impeller	54.00
	P78S68MLXXX	178 6 x 8 316-SS Left Hand Impeller	54.00
	P78D68MRXXX	178 6 x 8 Ductile Iron Right Hand Impeller	54.00
	P78D68MLXXX	178 6 x 8 Ductile Iron Left Hand Impeller	54.00
	P78A68MRXXX	178 6 x 8 Aluminum Bronze Right Hand Impeller	54.00
	P78A68MLXXX	178 6 x 8 Aluminum Bronze Left Hand Impeller	54.00

*See Impeller Size Code On Page 8

PARTS OPTIONS (Continued)

Item No.	Part No.	Description	Approx. Wt.
*14	P78S23H	178 2 x 3 316-SS Housing	61.00
	P78D23H	178 2 x 3 Ductile Iron Housing	62.00
	P78A23H	178 2 x 3 Aluminum Bronze Housing	62.00
	P78S34H	178 3 x 4 316-SS Housing	64.00
	P78D34H	178 3 x 4 Ductile Iron Housing	68.00
	P78A34H	178 3 x 4 Aluminum Bronze Housing	68.00
	P78S45H	178 4 x 5 316-SS Housing	87.00
	P78D45H	178 4 x 5 Ductile Iron Housing	88.00
	P78A45H	178 4 x 5 Aluminum Bronze Housing	88.00
	P78S56H	178 5 x 6 316-SS Housing	105.00
	P78D56H	178 5 x 6 Ductile Iron Housing	106.00
	P78A56H	178 5 x 6 Aluminum Bronze Housing	106.00
	P78S68H	178 6 x 8 316-SS Housing	204.00
	P78D68H	178 6 x 8 Ductile Iron Housing	206.00
	P78A68H	178 6 x 8 Aluminum Bronze Housing	206.00
*15	P78S23F	178 2 x 3 316-SS Face	60.00
	P78D23F	178 2 x 3 Ductile Iron Housing	62.00
	P78A23F	178 2 x 3 Aluminum Bronze Housing	66.00
	P78S34F	178 3 x 4 316-SS Face	65.00
	P78D34F	178 3 x 4 Ductile Iron Housing	66.00
	P78A34F	178 3 x 4 Aluminum Bronze Housing	68.00
	P78S45F	178 4 x 5 316-SS Face	66.00
	P78D45F	178 4 x 5 Ductile Iron Housing	70.00
	P78A45F	178 4 x 5 Aluminum Bronze Housing	70.00
	P78S56F	178 5 x 6 316-SS Face	82.00
	P78D56F	178 5 x 6 Ductile Iron Housing	84.00
	P78A56F	178 5 x 6 Aluminum Bronze Housing	84.00
	P78S68F	178 6 x 8 316-SS Face	83.00
	P78D68F	178 6 x 8 Ductile Iron Housing	85.00
	P78A68F	178 6 x 8 Aluminum Bronze Housing	85.00
*14/15	P78A23HFA(Z)	178 2 x 3 Aluminum Bronze Housing Assembly	132.00
	P78S23HFA(Z)	178 2 x 3 316-SS Housing Assembly	132.00
	P78D23HFA(Z)	178 2 x 3 Ductile Iron Housing Assembly	132.00
	P78A34HFA(Z)	178 3 x 4 Aluminum Bronze Housing Assembly	140.00
	P78S34HFA(Z)	178 3 x 4 316-SS Housing Assembly	140.00
	P78D34HFA(Z)	178 3 x 4 Ductile Iron Housing Assembly	140.00
	P78A45HFA(Z)	178 4 x 5 Aluminum Bronze Housing Assembly	156.00
	P78S45HFA(Z)	178 4 x 5 316-SS Housing Assembly	156.00
	P78D45HFA(Z)	178 4 x 5 Ductile Iron Housing Assembly	156.00
	P78A56HFA(Z)	178 5 x 6 Aluminum Bronze Housing Assembly	190.00
	P78S56HFA(Z)	178 5 x 6 316-SS Housing Assembly	190.00
	P78D56HFA(Z)	178 5 x 6 Ductile Iron Housing Assembly	190.00
	P78S68HFA(Z)	178 6 x 8 316-SS Housing Assembly	290.00
	P78D68HFA(Z)	178 6 x 8 Ductile Iron Housing Assembly	290.00

NOTE: (Z) refers to optional right or left hand rotation.

178 SERIES

Dimensional Outline

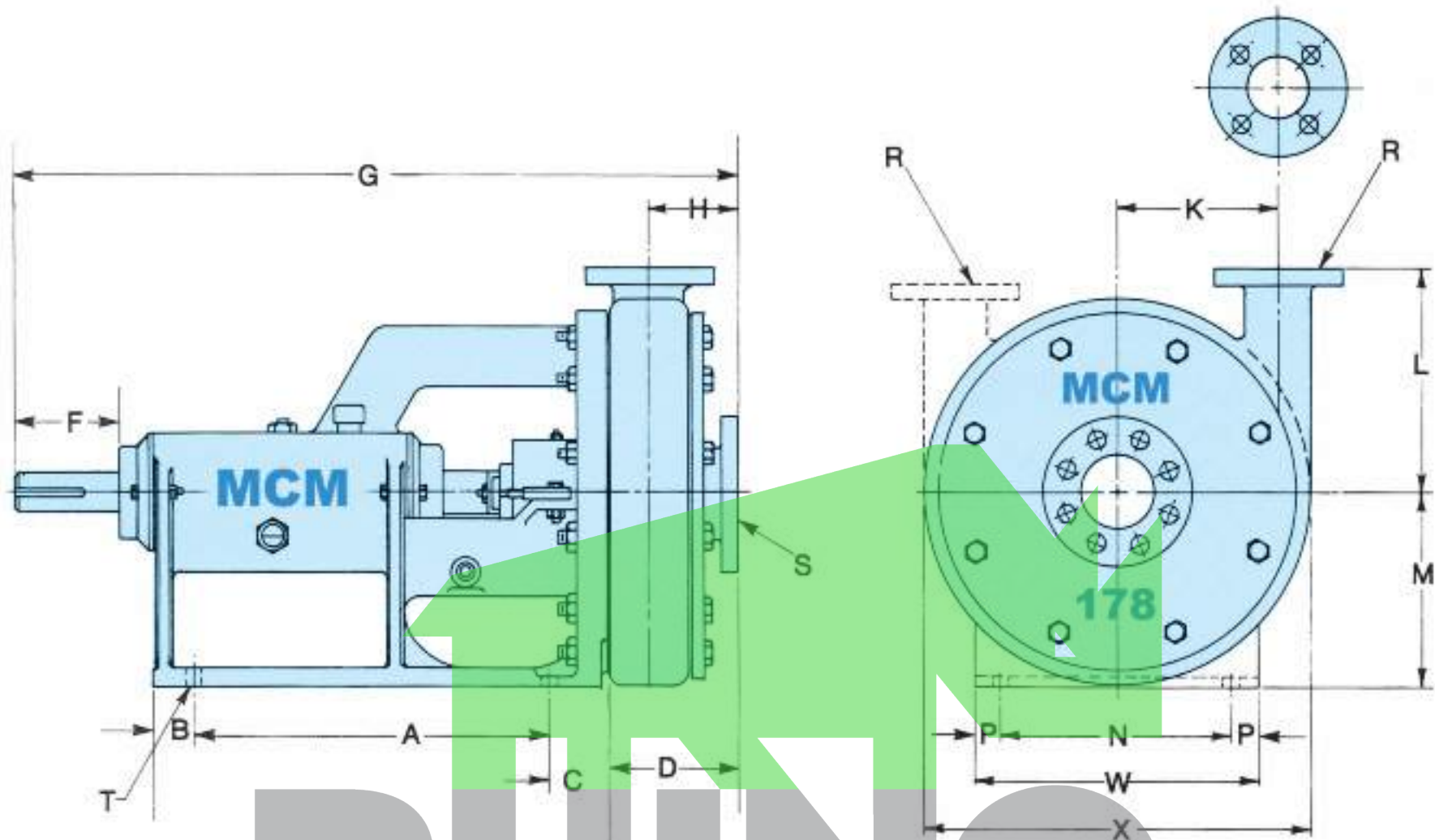

PEDESTAL, HOUSING, & INSTALLATION DIMENSIONS

PUMP SIZE	A	B	C	D	F	G	H	K	L	M	N	P	R	S	T	W	X
2x3	16½	1 ¹¹ / ₁₆	2¼	6	5	33½	4	7	10¼	9	7	1	2	3	(4)- ¹ / ₁₆	9	18
3x4	16½	1 ¹¹ / ₁₆	2¼	6 ³ / ₈	5	34½	4¼	7½	10¼	9	7	1	3	4	(4)- ¹ / ₁₆	9	18
4x5	16½	1 ¹¹ / ₁₆	2¼	6 ³ / ₈	5	35¾	5½	7	11	9	7	1	4	5	(4)- ¹ / ₁₆	9	18
5x6	16½	1 ¹¹ / ₁₆	2¼	8¾	5	36¾	5¾	6	11	9	7	1	6	8	(4)- ¹ / ₁₆	9	18
6x8	16½	1 ¹¹ / ₁₆	2¼	10 ¹ / ₈	5	37 ³ / ₈	6¼	8 ³ / ₈	14¼	9	7	1	6	8	(4)- ¹ / ₁₆	9	23

FLANGE SIZES

Pump Size	Pump Type (Shaft Dia.)	Discharge Pipe		Suction Pipe	
		Size	Drilling	Size	Drilling
2x3-R & L	1 ¹ / ₈	2	4 Holes ³ / ₄ Dia. 4¾ B.C.	3	4 Holes ³ / ₄ Dia. 6 B.C.
3x4-R & L	1 ¹ / ₈	3	8 Holes ³ / ₄ Dia. 6 B.C.	4	8 Holes ³ / ₄ Dia. 7½ B.C.
4x5-R & L	1 ¹ / ₈	4	8 Holes ³ / ₄ Dia. 7½ B.C.	5	8 Holes ⁷ / ₈ Dia. 8½ B.C.
5x6-R & L	1 ¹ / ₈	5	8 Holes ⁷ / ₈ Dia. 8½ B.C.	6	8 Holes ⁷ / ₈ Dia. 9½ B.C.
6x8-R & L	1 ¹ / ₈	6	8 Holes ⁷ / ₈ Dia. 9½ B.C.	8	8 Holes ⁷ / ₈ Dia. 11¼ B.C.

ISO 9001-2000 Certified

178 SERIES

Performance Curves

2 x 3 1150 RPM

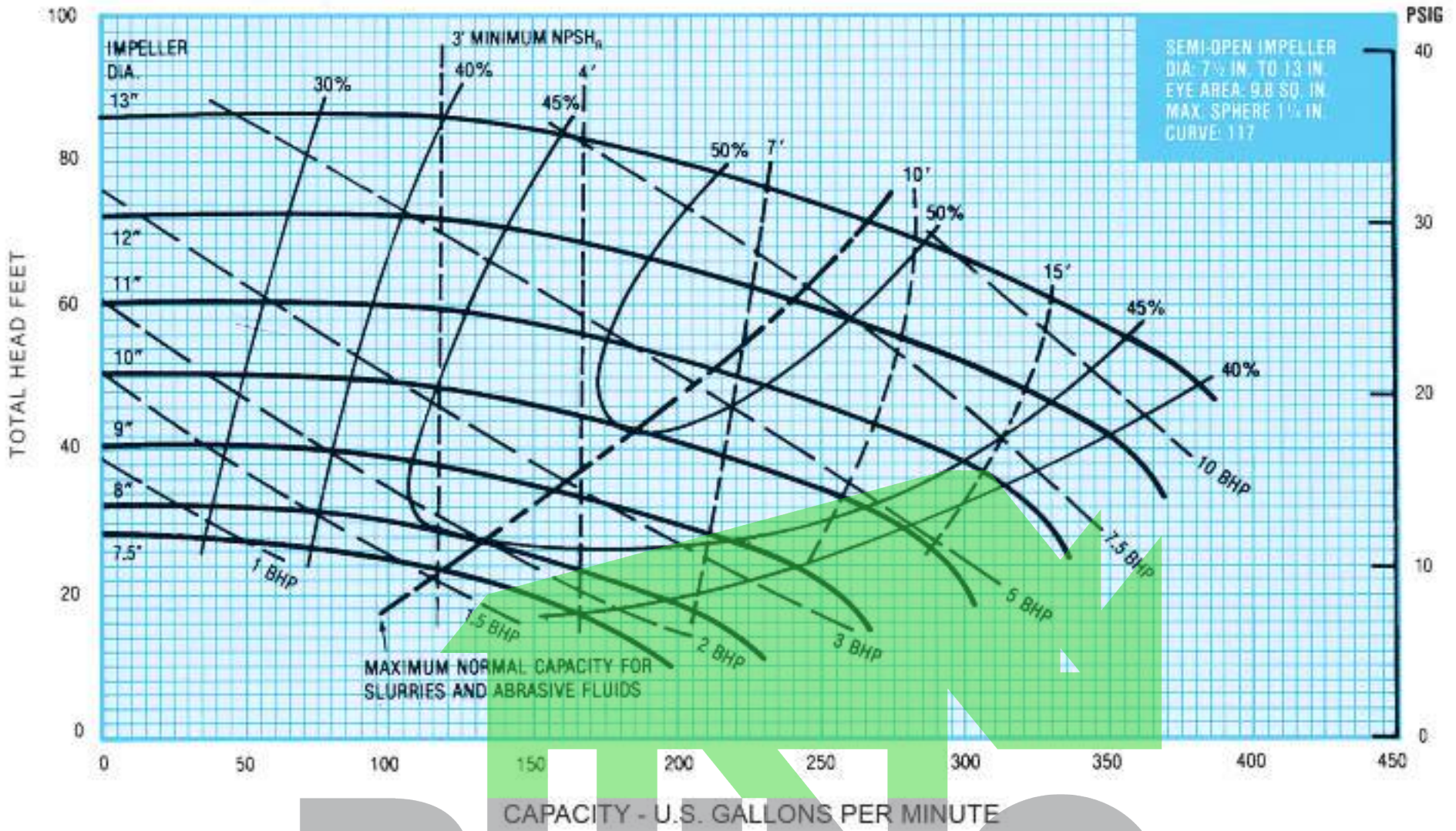

RHINO

2 x 3 1750 RPM

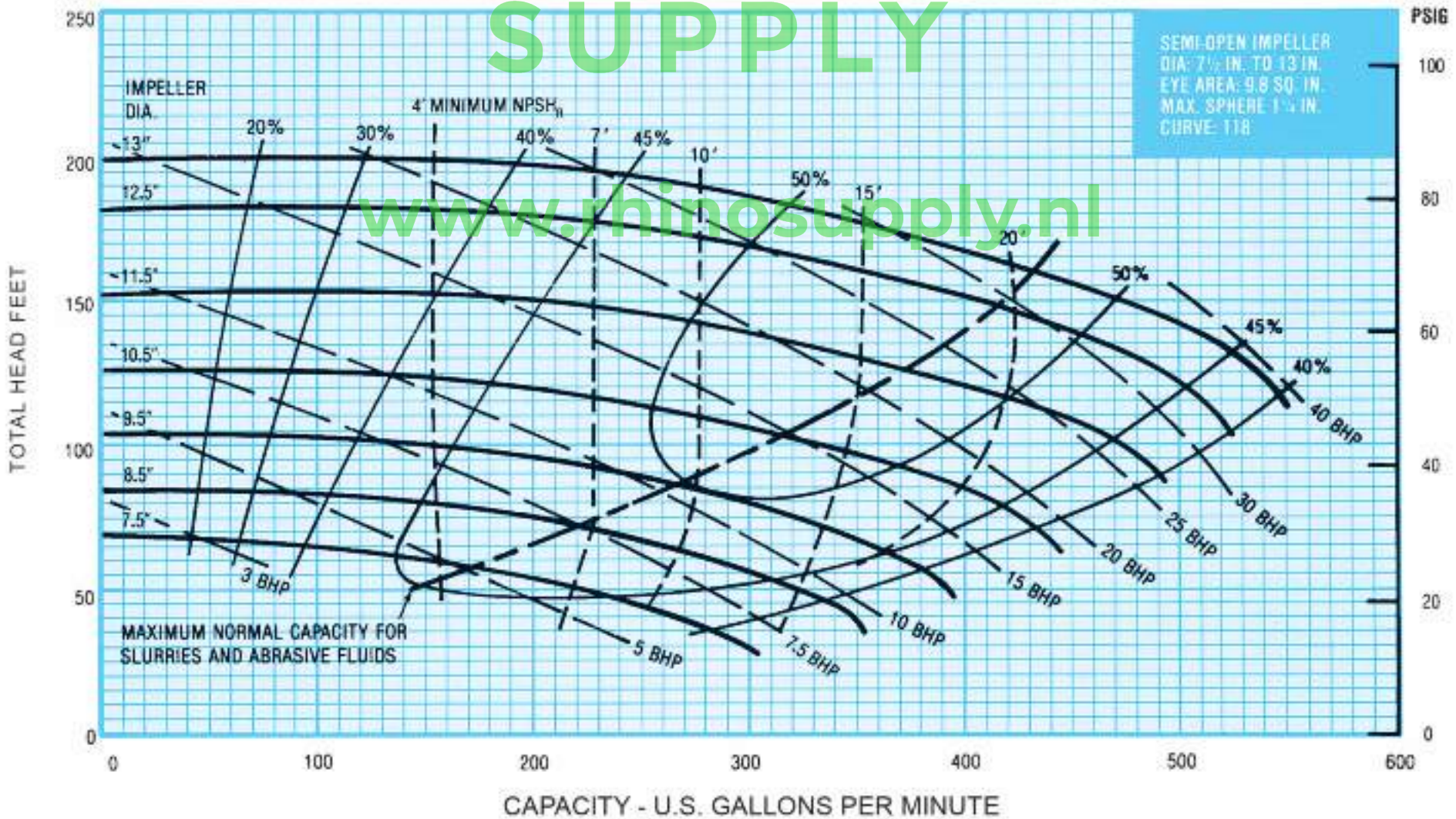

Curves show performance with clear water. If specific gravity is other than 1.0, curve HP must be corrected.

2 x 3 3500 RPM

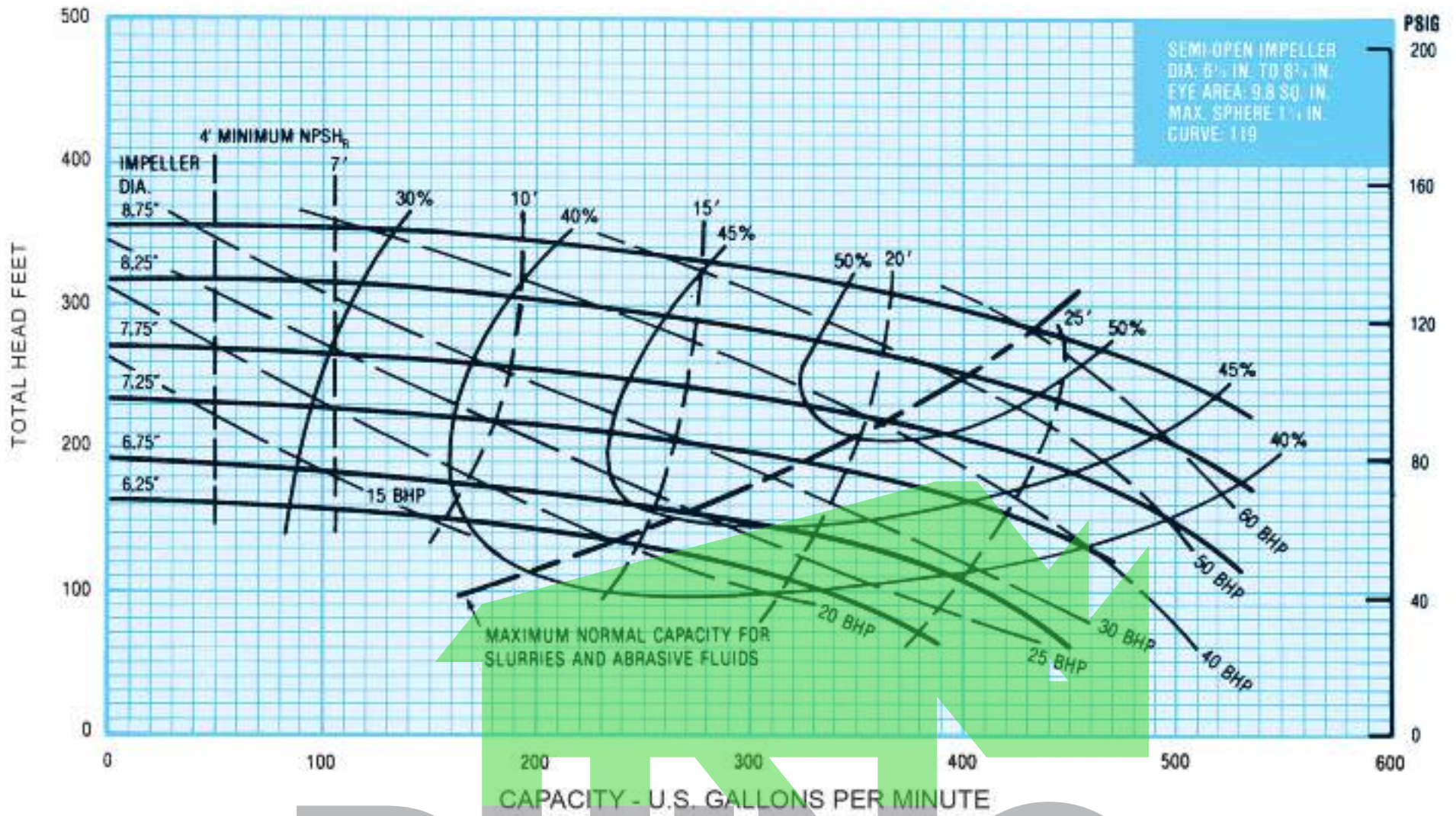

RHINO

2 x 3 700-2500 RPM

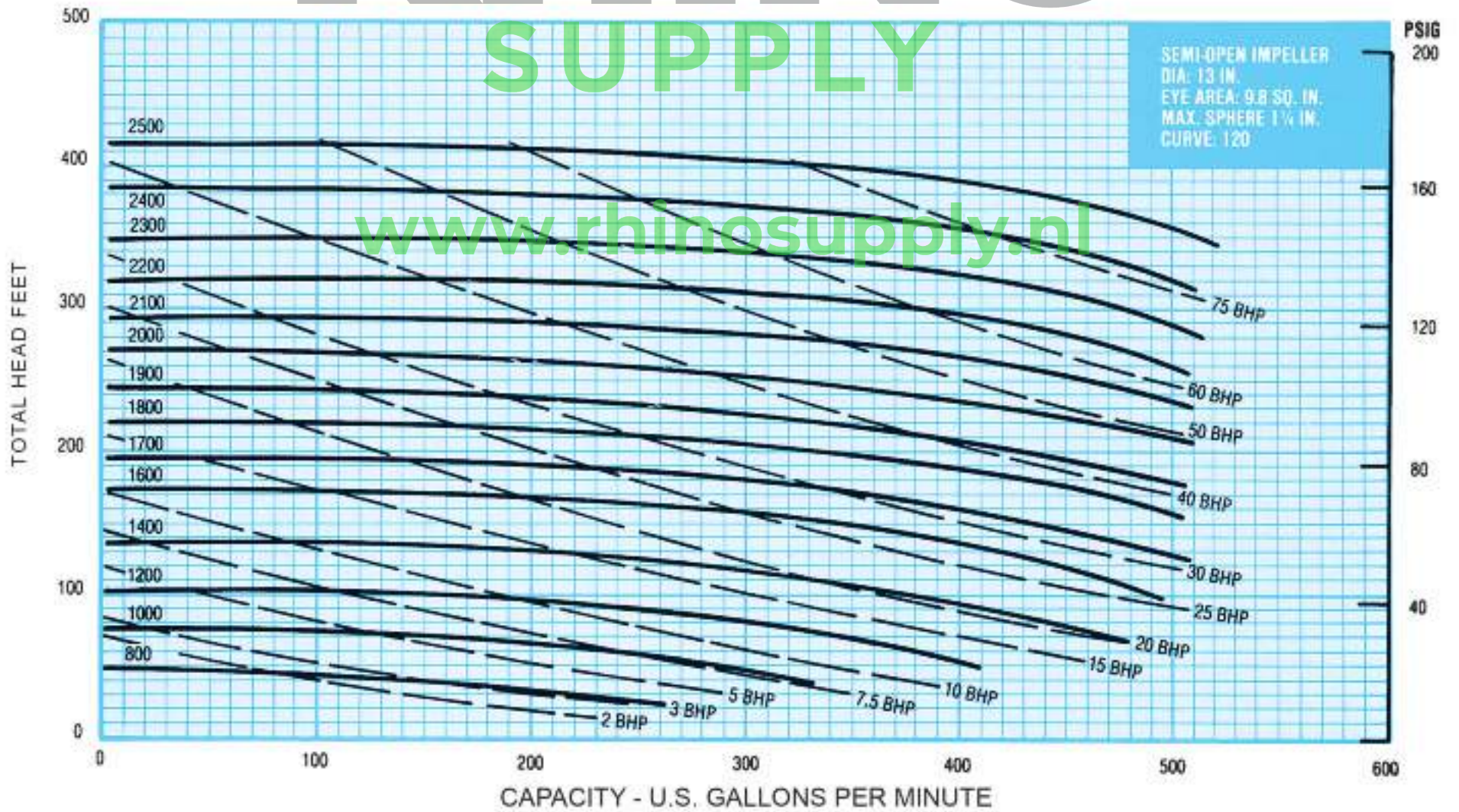

www.rhinosupply.nl

Curves show performance with clear water. If specific gravity is other than 1.0, curve HP must be corrected.

178 SERIES



3 x 4 1150 RPM

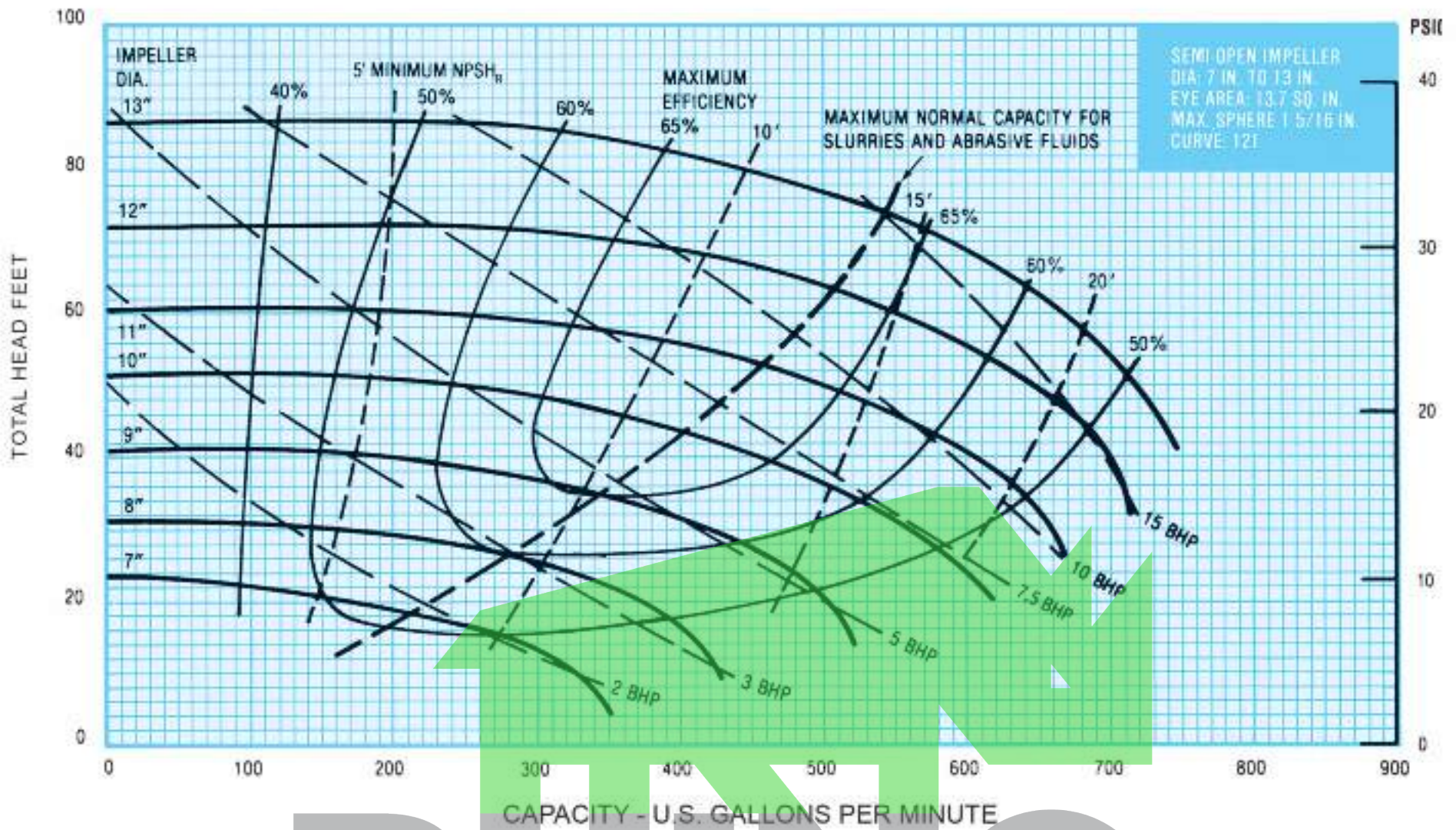

RHINO

3 x 4 1750 RPM

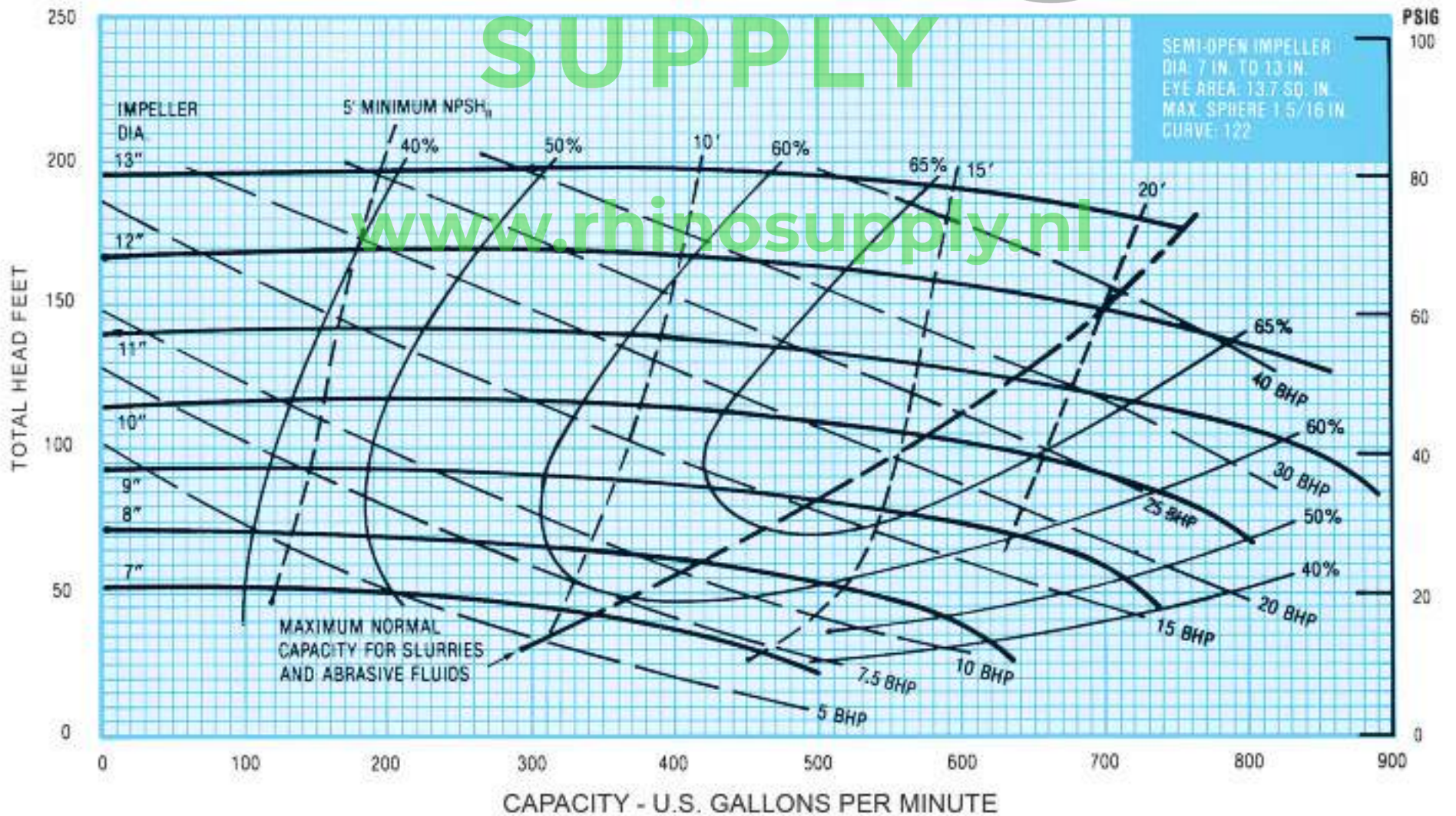

Curves show performance with clear water. If specific gravity is other than 1.0, curve HP must be corrected.

3 x 4 3500 RPM

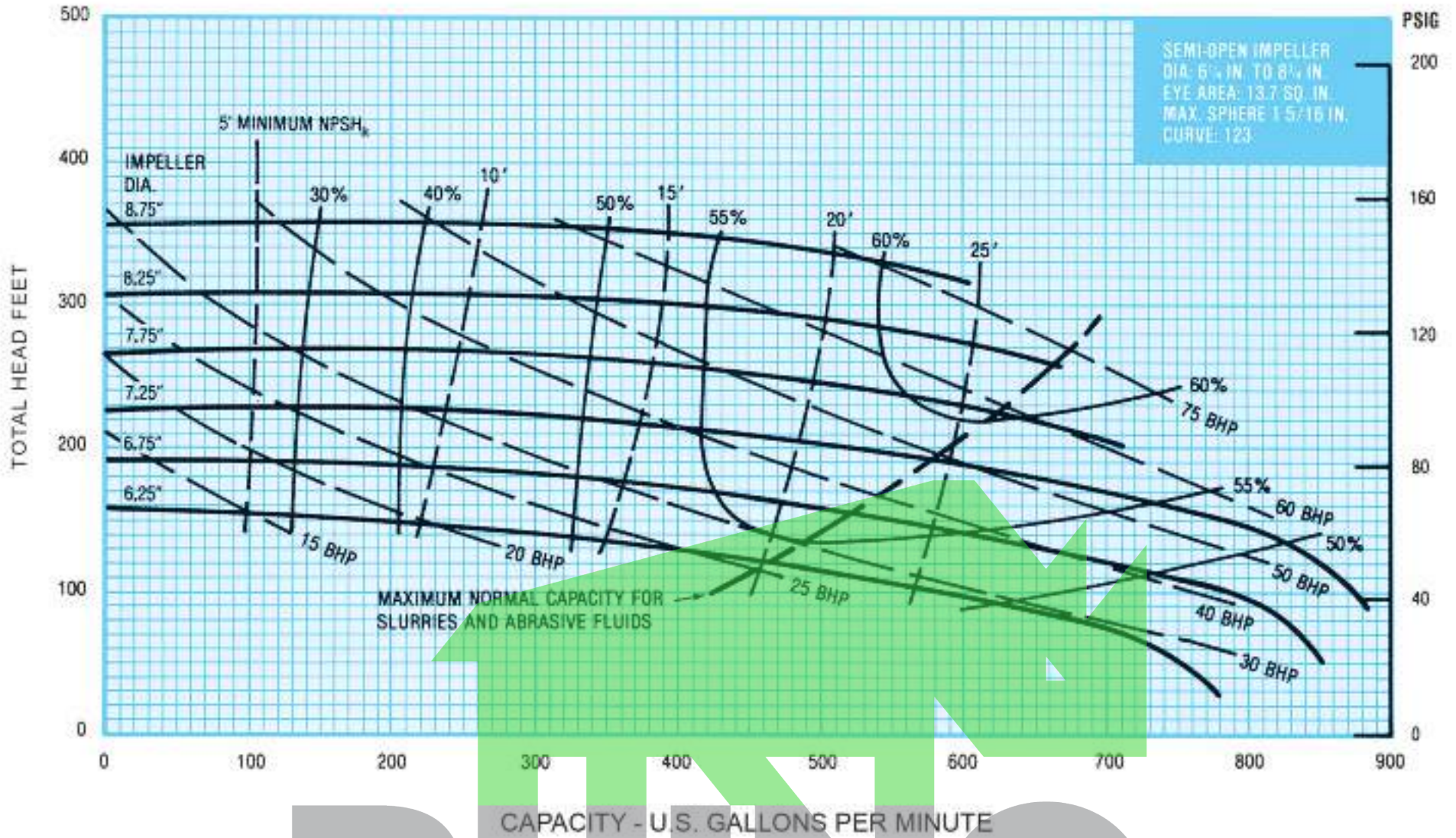

RHINO
SUPPLY

3 x 4 1000-2400 RPM

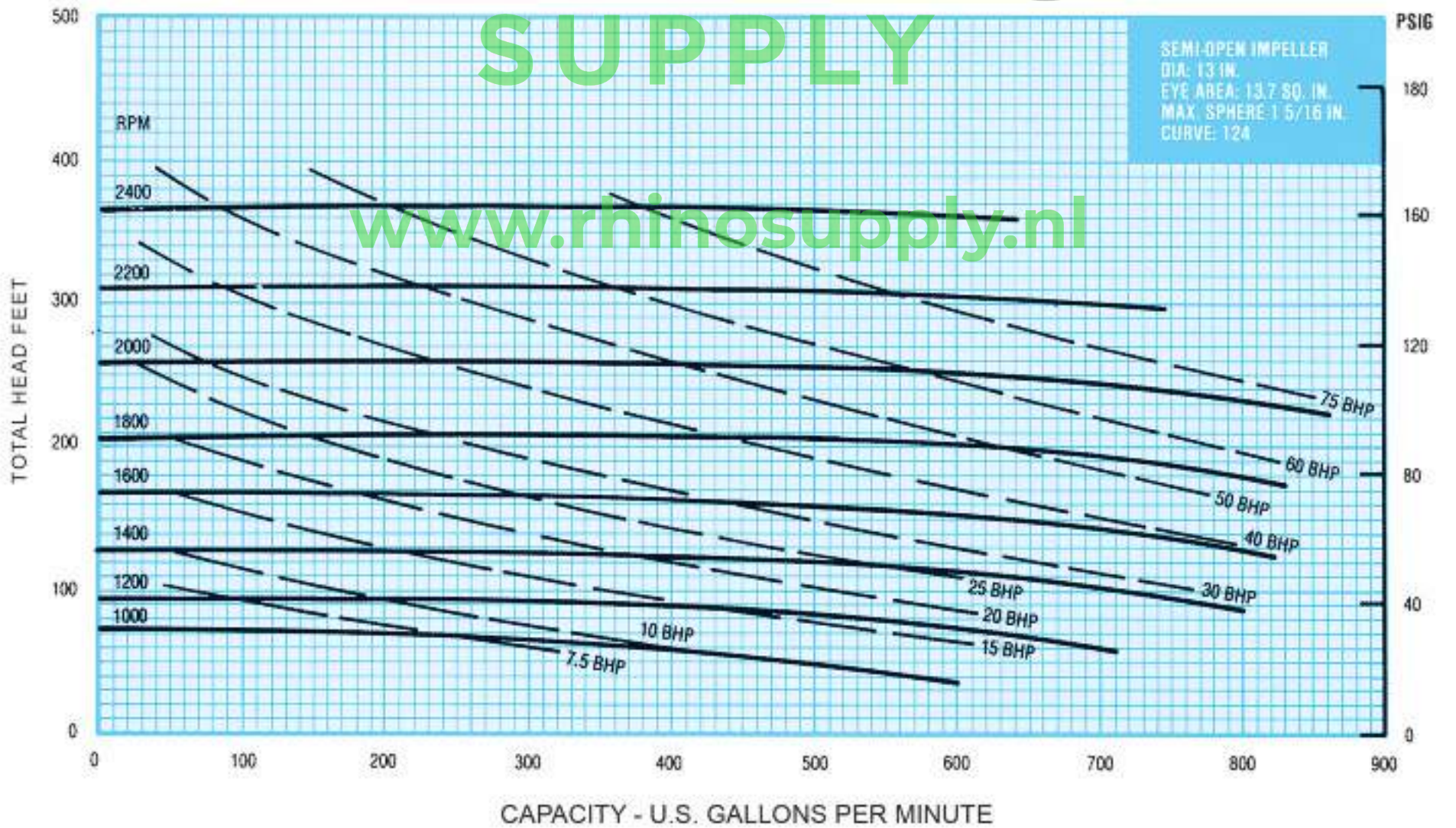

Curves show performance with clear water. If specific gravity is other than 1.0, curve HP must be corrected.

4 x 5 1150 RPM

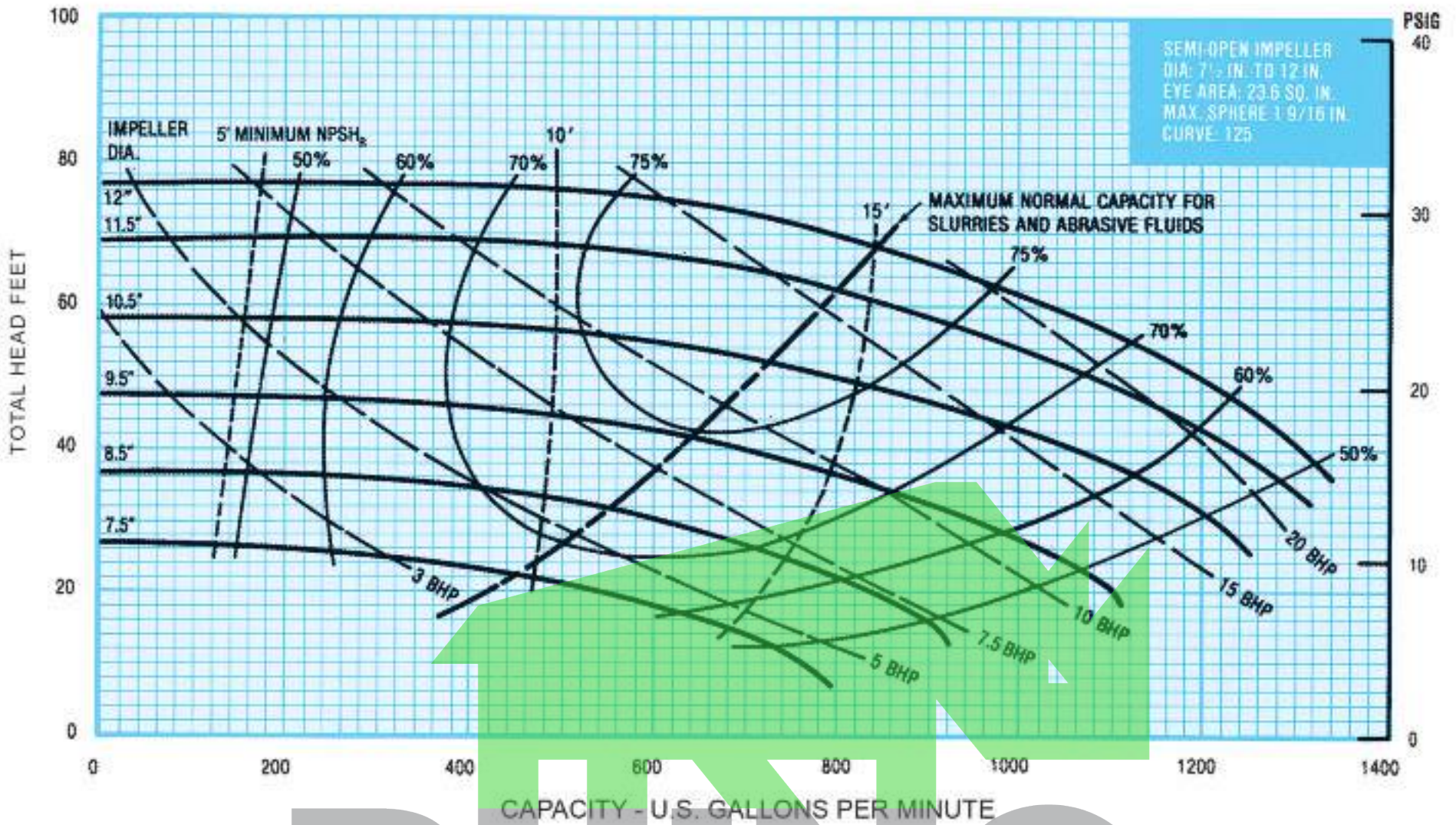

RHINO

SUPPLY

www.rhinosupply.com

4 x 5 1750 RPM

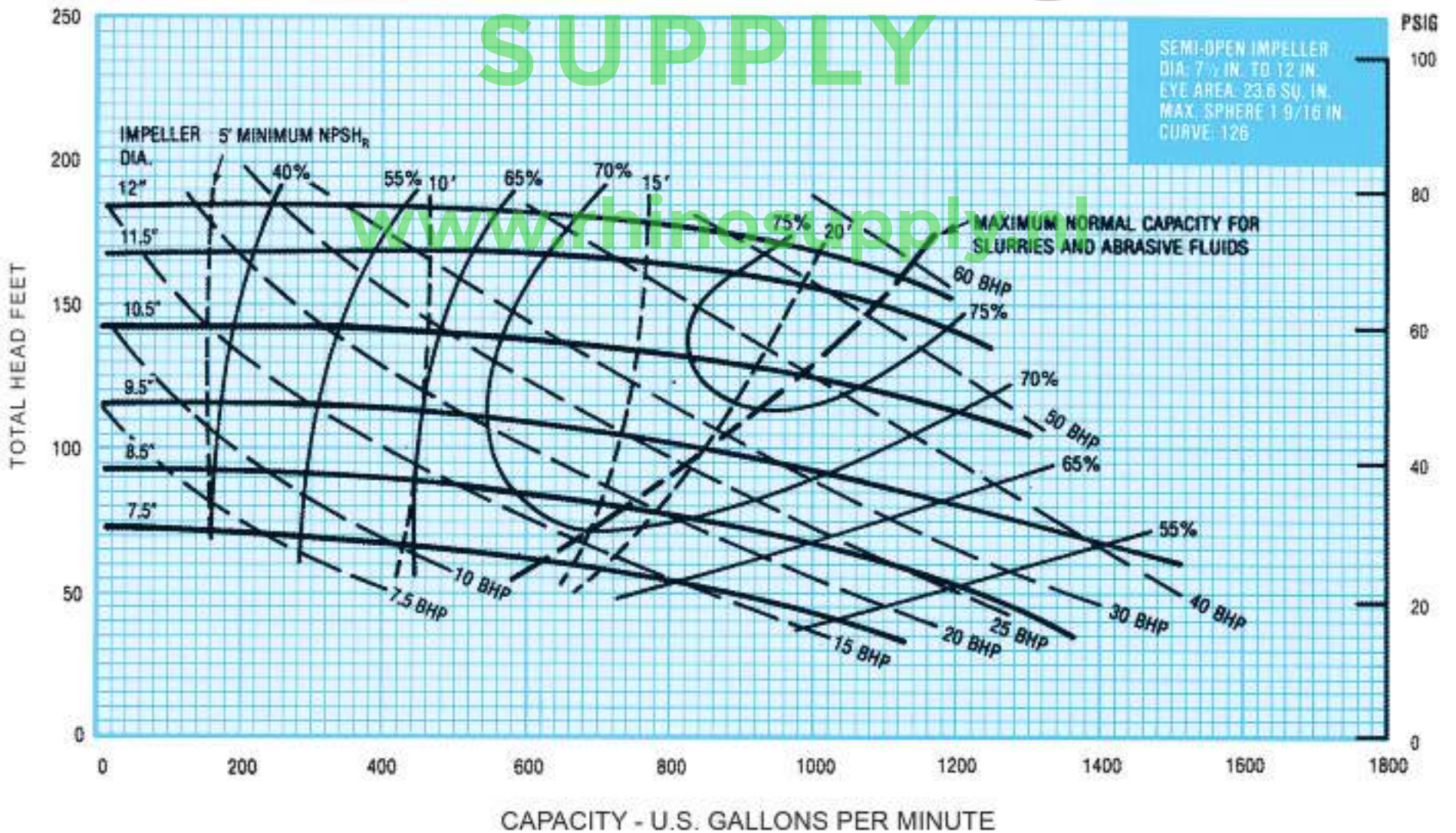

Curves show performance with clear water. If specific gravity is other than 1.0, curve HP must be corrected.

4 x 5 800-2000 RPM

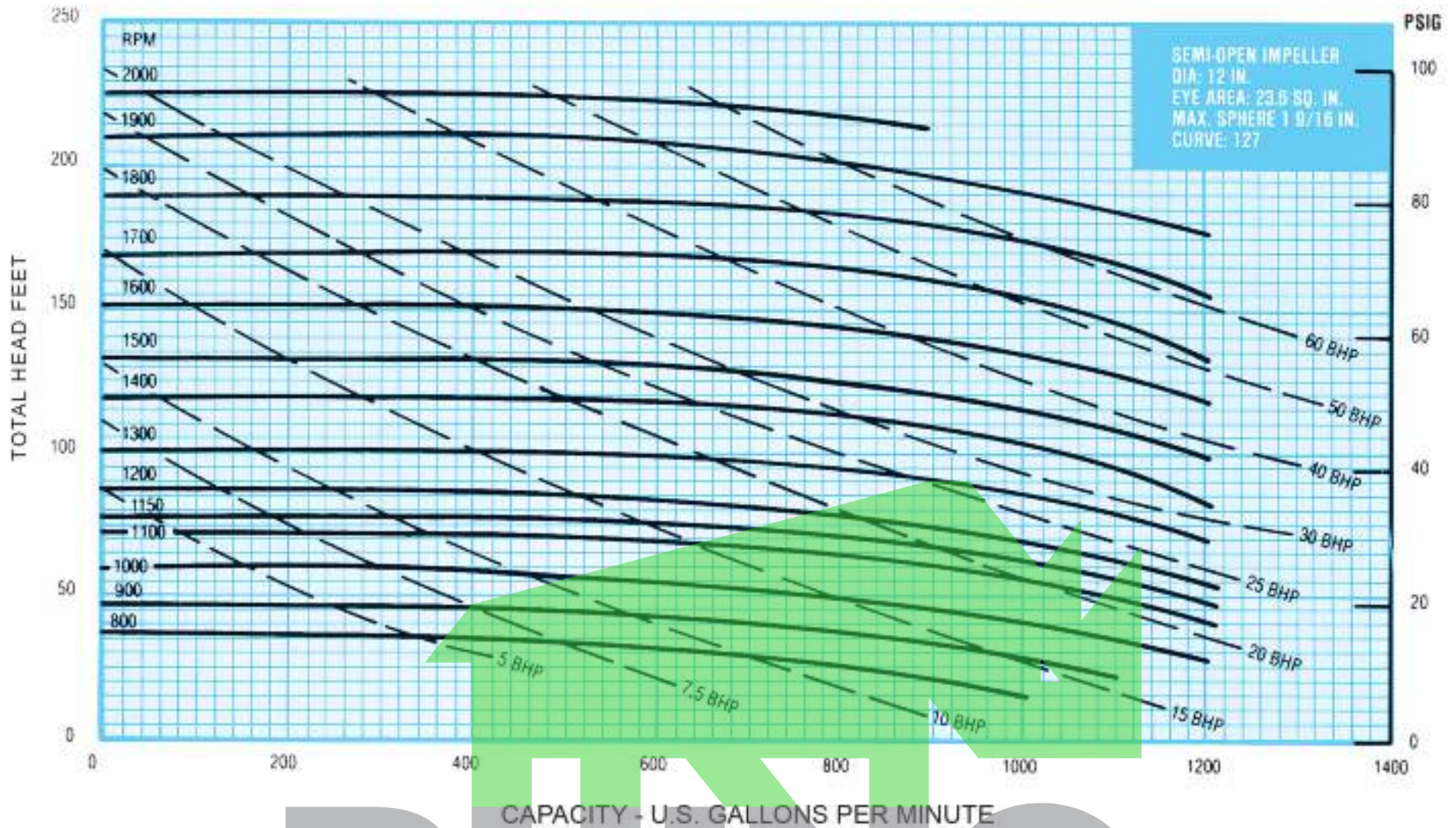

RHINO
SUPPLY
www.rhinosupply.nl

5 x 6 1150 RPM

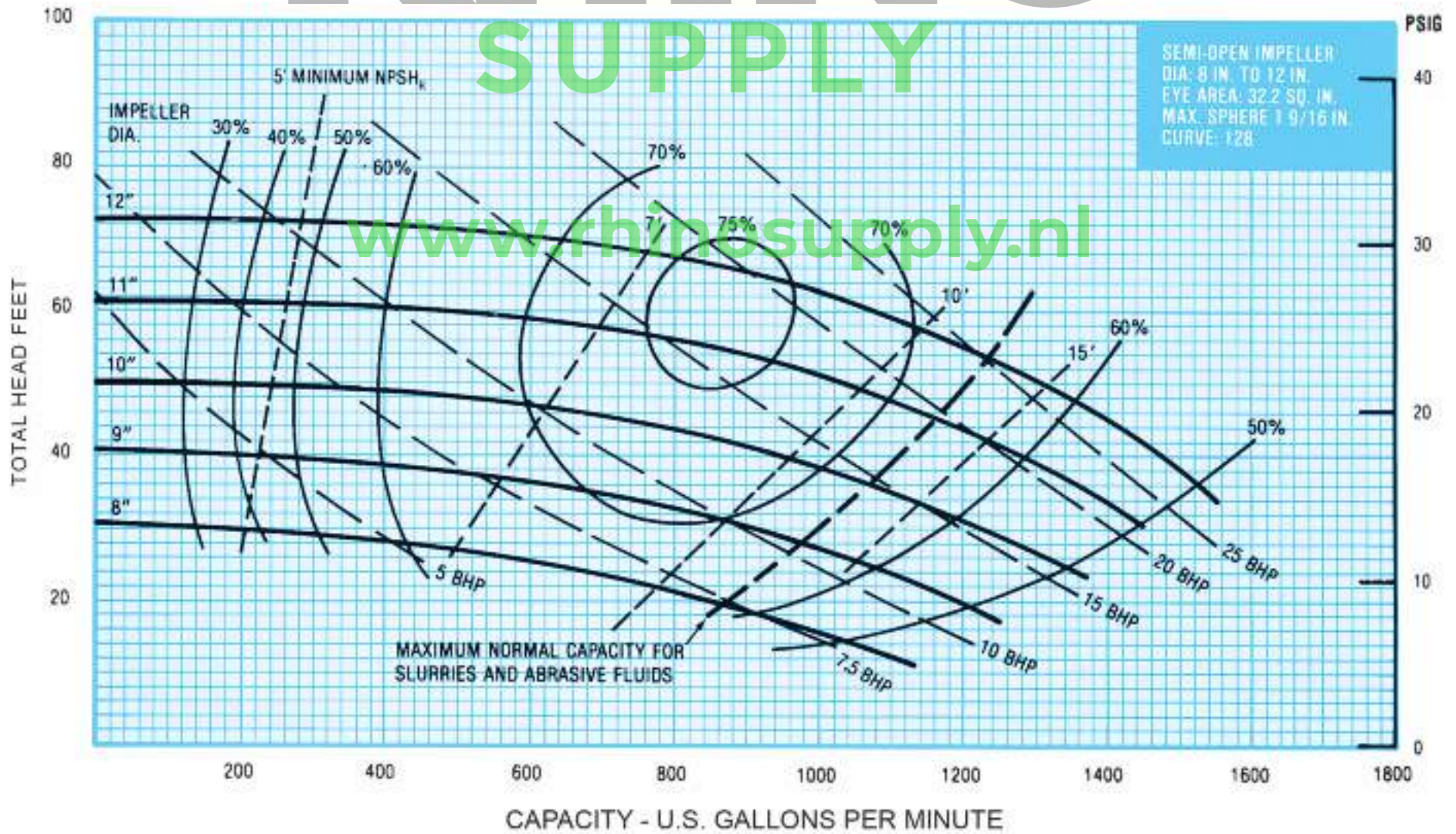

Curves show performance with clear water. If specific gravity is other than 1.0, curve HP must be corrected.

5 x 6 1750 RPM

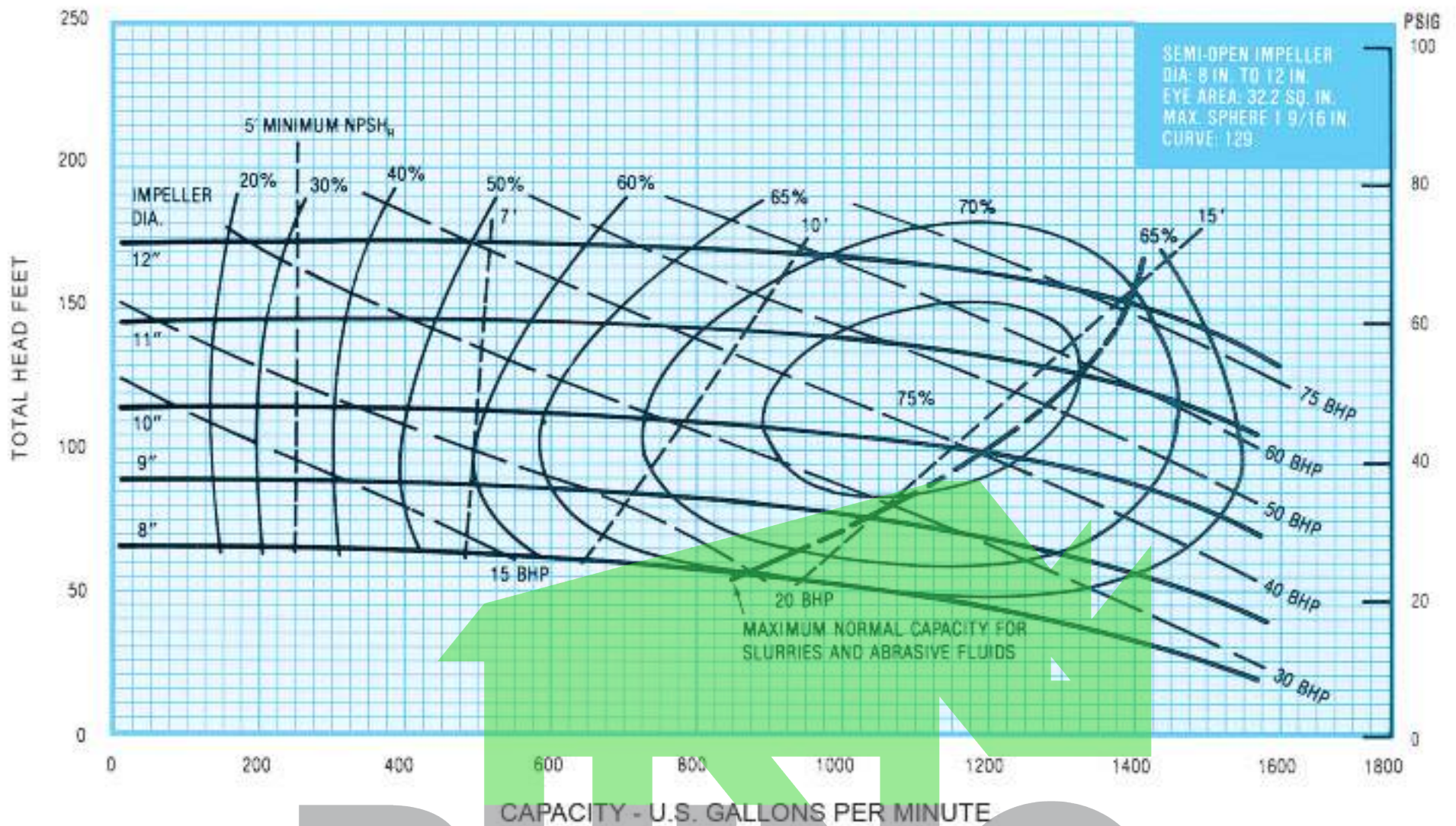

RHINO

5 x 6 800-1800 RPM

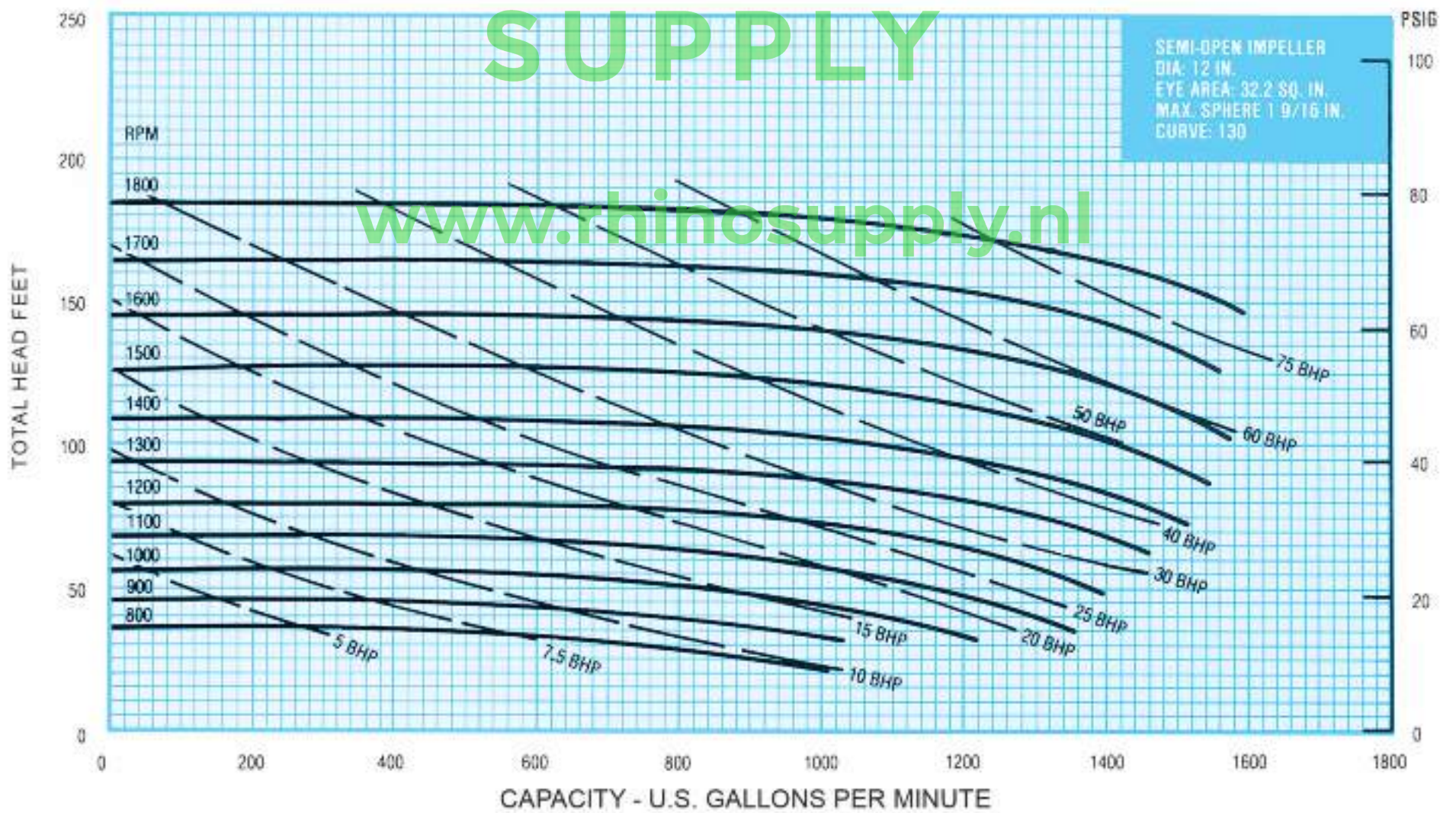

6 x 8 1150 RPM

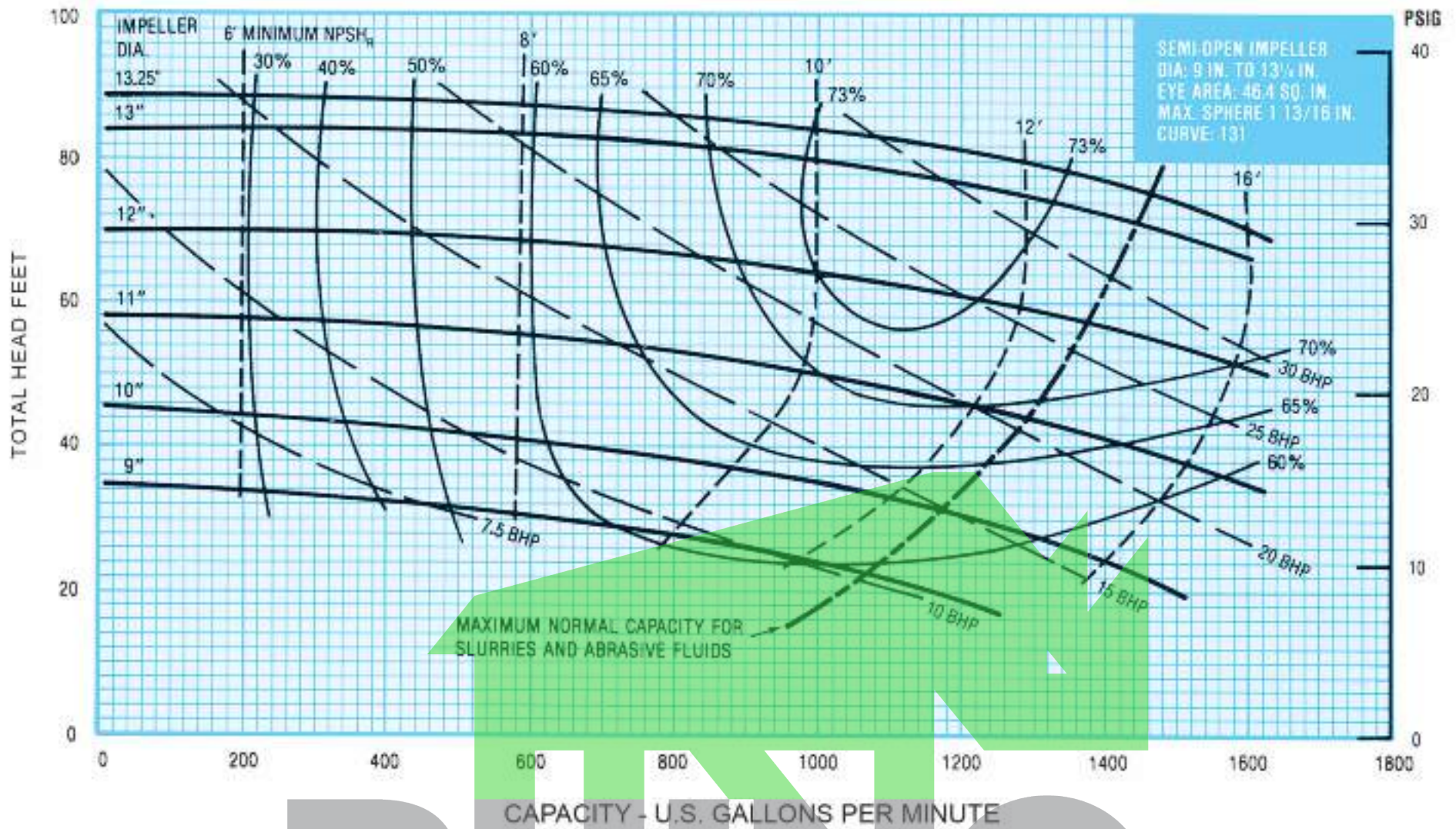

RHINO

6 x 8 1750 RPM

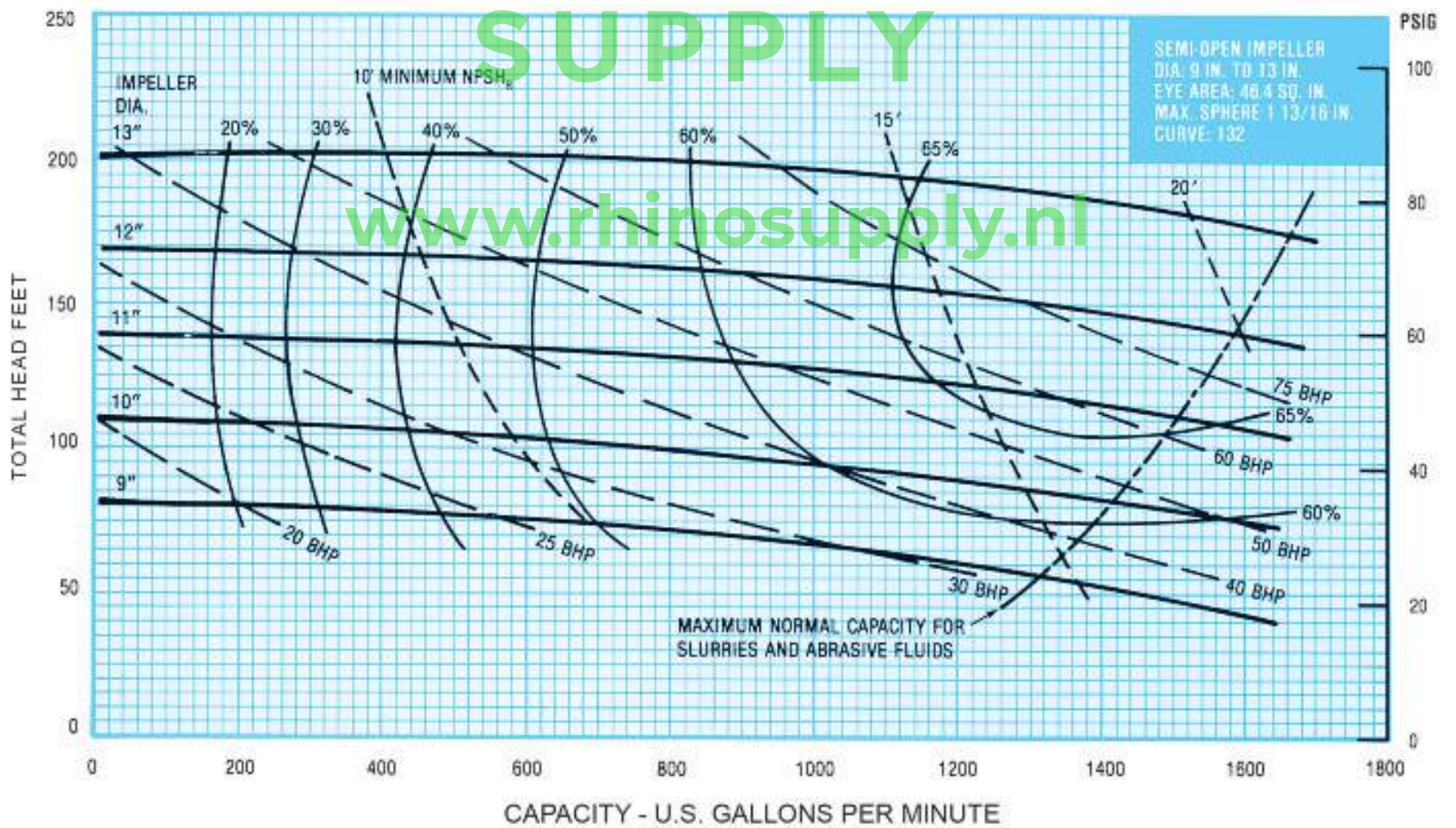

Curves show performance with clear water. If specific gravity is other than 1.0, curve HP must be corrected.

178 SERIES



6 x 8 700-1700 RPM

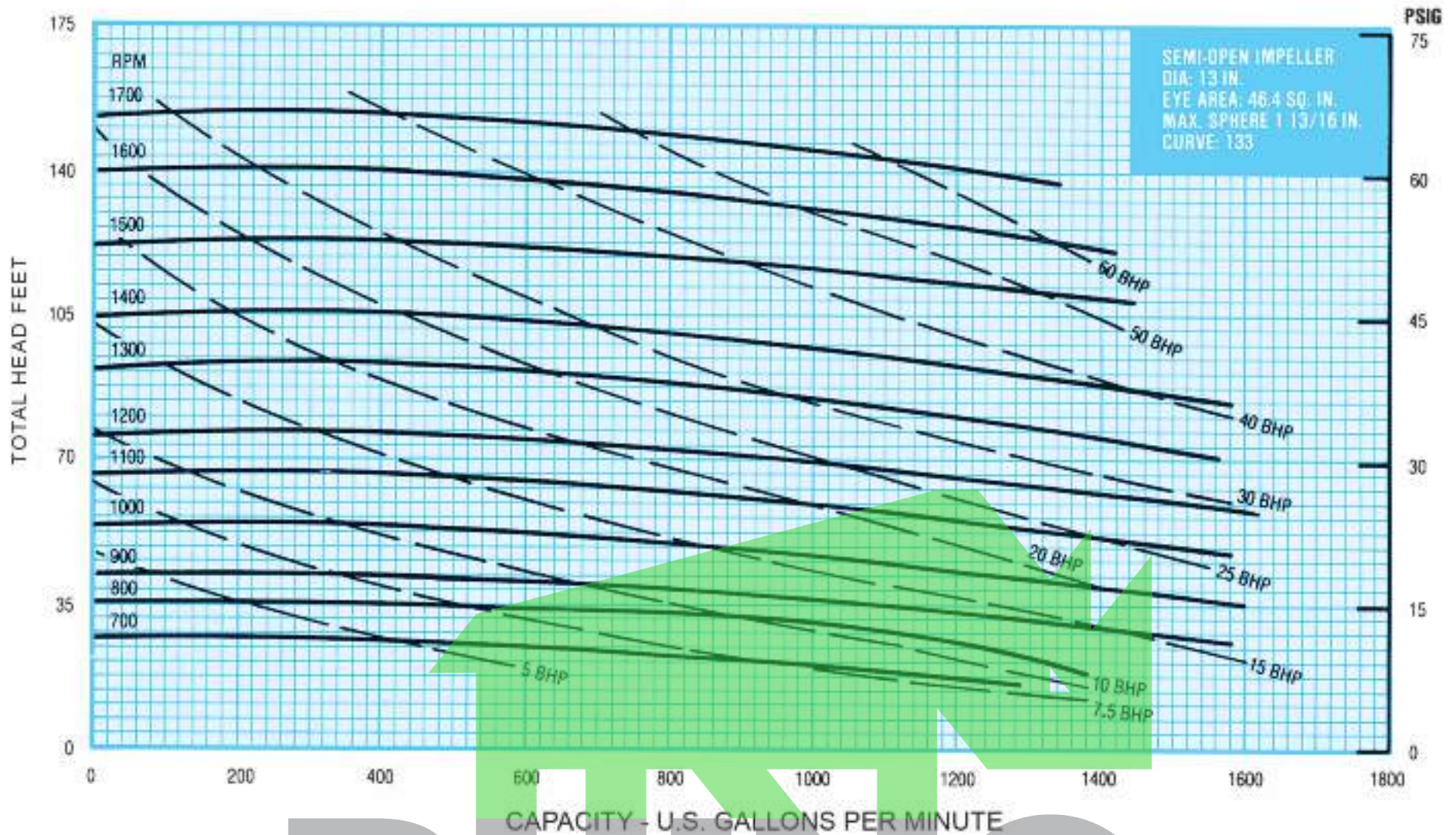

RHINO
SUPPLY

CONVERSION DATA

FEET	PSI	FEET	PSI
10	4.33	23.1	10
20	8.66	46.2	20
25	10.80	57.8	25
30	13.00	69.3	30
40	17.30	80.9	35
50	21.60	92.4	40
75	32.48	104.0	45
100	43.20	115.5	50
150	64.80	138.6	60
200	86.40	173.2	75
250	108.00	231.0	100
300	130.00	288.7	125
350	151.60	346.5	150
400	172.80	404.2	175

Curves show performance with clear water. If specific gravity is other than 1.0, curve HP must be corrected.

250 SERIES *Parts Diagram*

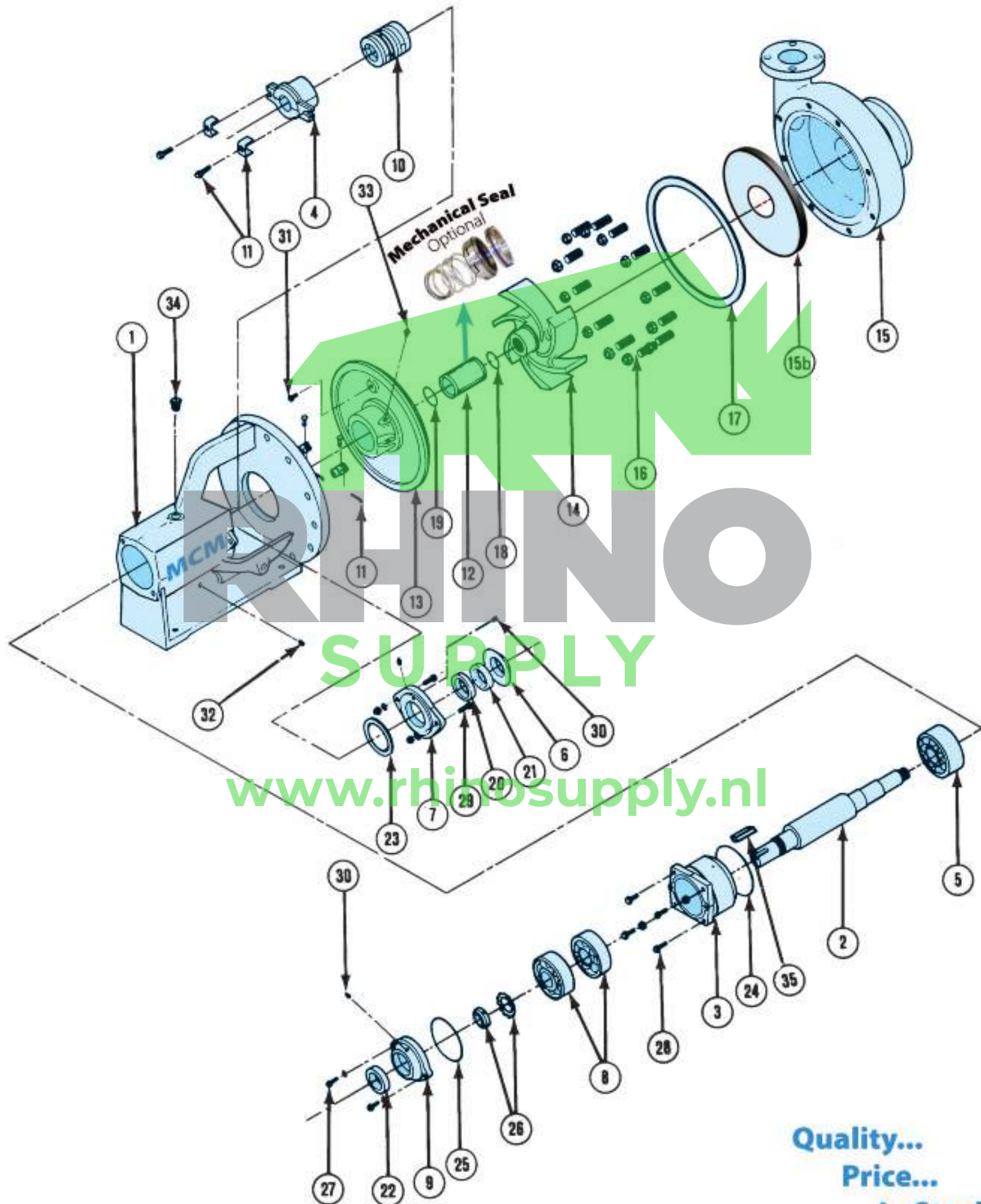

Quality...
Price...
In Stock!

250 PUMP SIZES

PUMP SIZE	MODEL NO.	MATERIAL	ROTATION	MAX. IMPELLER
2x3x13	CP25233DRXXX	Ductile Iron	RH	13"
3x4x13	CP25343DRXXX	Ductile Iron	RH	13"
4x5x14	CP25454DRXXX	Ductile Iron	RH	14"
5x6x11	CP25561DRXXX	Ductile Iron	RH	11"
5x6x14	CP25564DRXXX	Ductile Iron	RH	14"
6x8x11	CP25681DRXXX	Ductile Iron	RH	11"
6x8x14	CP25684DRXXX	Ductile Iron	RH	14"

NOTE: Add /MS to above model numbers for pumps with Mechanical Seals.

250 PUMP PARTS LIST

Item No.	Part No.	Description	Qty. Req'd.	Approx. Wt.
1	P25PED	250 Pedestal	1	165.00
2	P25SHFT	250 Shaft	1	38.00
3	P25OBBH	250 Outboard Bearing Housing	1	9.50
4	P25PG	250 Packing Gland	1	2.50
5	P25IBBRG	250 Inboard Bearing	1	8.50
6	P25SRW	250 Slinger Ring - Water	1	.75
7	P25IBBC	250 Inboard Bearing Cover	1	5.50
8	P25OBBRG	250 Outboard Bearing	2	3.50
9	P25OBBC	250 Outboard Bearing Cover	1	3.50
*10	*	250 Mechanical Seal / 250 Packing Assembly	1	1.00
11	P25GABA	250 Gland Bolt Assembly	2	.25
11A	P25CGB	250 Clevis Gland Bolt	2	.50
12	P25SHSLVC	250 Shaft Sleeve, Ceramic Coated	1	2.50
*13	*	250 Stuffing Box	1	42.00
*14	*	250 Impeller	1	*
*15	*	250 Housing	1	*
*15b	P25CWPxxx	250 Replaceable Wear Pad		*
16	P25HSN	250 Housing Stud W/ Nut	2	.50
*17	P25HG	250 Housing Gasket	1	.50
*18	P25IMS	250 Impeller Seal / O-Ring	1	.50
*19	P25SSS	250 Shaft Sleeve Seal / O-Ring	1	.50
*20	P25IBBOS	250 Inboard Bearing Oil Seal	1	.50
*21	P25IBBES	250 Inboard Bearing Exclusion Seal	1	.50
*22	P25OBBOS	250 Outboard Bearing Oil Seal	1	.50
*23	P25IBBCG	250 Inboard Bearing Cover Gasket	1	.50
*24	P25OBBHS	250 Otbd. Bearing Housing Seal / O-Ring	1	.50
*25	P25OBBCS	250 Otbd. Bearing Cover Seal / O-Ring	1	.50
26	P25BLNK	250 Bearing Lock Nut Kit	1	1.00
27	P25OBBCB	250 Outboard Bearing Cover Bolt	2	.10
28	P25BHB	250 Bearing Housing Bolt	4	.15
29	P25IBBCB	250 Inboard Bearing Cover Bolt	2	.15
30	P25BCP	250 Bearing Cover Plugs	2	.05
31	P25SBB	250 Stuff Box Bolt	1	.15
32	P25ODP	250 Oil Drain Plug	1	.05
33	P25ZGF	250 Zert Grease Fitting	1	.05
34	P25ODS	250 Oil Dip Stick	1	.25
35	P25CK	250 Coupling Key	1	.20

*See Options On Page 39

250 SERIES

Item No.	Part No.	Description	Approx. Wt.
*10	P25PMSG	250 Graphite Packing Assembly	1.00
	P25PMSK	250 King Packing Assembly	1.00
	P25PMST	250 Teflon Packing Assembly	1.00
	P25MSXX	250 Mechanical Seal	4.00
*13	P25SB/PK	250 Stuffing Box For Packed Pumps	42.00
	P25SB/MS	250 Stuffing Box For Mechanical Seals	42.00
*14	P25D233MRXXX	250 2x3x13 Ductile Iron Right Hand Impeller	21.00
	P25D343MRXXX	250 3x4x13 Ductile Iron Right Hand Impeller	25.00
	P25D454MRXXX	250 4x5x14 Ductile Iron Right Hand Impeller	42.00
**	P25D561MRXXX	250 5x6x11 Ductile Iron Right Hand Impeller	31.00
	P25D564MRXXX	250 5x6x14 Ductile Iron Right Hand Impeller	45.00
	P25D684MRXXX	250 6x8x14 Ductile Iron Right Hand Impeller	47.00
**Note: Use P25D561MRXXX for 250 6x8x11 Pumps			
*15	P25D233H	250 2x3x13 Ductile Iron Right Hand Housing	121.00
	P25D343H	250 3x4x13 Ductile Iron Right Hand Housing	145.00
	P25D454H	250 4x5x14 Ductile Iron Right Hand Housing	183.00
	P25D561H	250 5x6x11 Ductile Iron Right Hand Housing	215.00
	P25D564H	250 5x6x14 Ductile Iron Right Hand Housing	237.00
	P25D681H	250 6x8x11 Ductile Iron Right Hand Housing	250.00
	P25D684H	250 6x8x14 Ductile Iron Right Hand Housing	257.00
*15b	P25CWP343	250 F/ 3 x 4 x 13 Casing Wear Pad	30.00
	P25CWP454	250 F/ 4 x 5 x 14 Casing Wear Pad	30.00
	P25CWP561	250 F/ 5 x 6 x 11 Casing Wear Pad	30.00
	P25CWP564	250 F/ 5 x 6 x 14 Casing Wear Pad	30.00
	P25CWP681	250 F/ 6 x 8 x 11 Casing Wear Pad	30.00
	P25CWP684	250 F/ 6 x 8 x 14 Casing Wear Pad	30.00
	P25CWP8104	250 F/ 8 x 10 x 14 Casing Wear Pad	30.00
*17			
*18	P25FEGK	250 Fluid Gasket Kit	.50
*19			
*20			
*21	P25OSK	250 Oil Seal Kit	.75
*22			
*23			
*24	P25PEGK	250 Power End Gasket Kit	.50
*25			
Note: See Impeller Size Code On Page 8			

MCM Heavy Duty Pedestal

MCM prides itself in manufacturing a heavy-duty frame to withstand high piping loads. The frame is manufactured from cast iron for high strength and durability.



MCM Casing

The MCM pump housing has been beefed up in critical wear areas for extra life. The concentric housing eliminates vibration, turbulence and cavitation and reduces bearing load and shaft deflection.



MCM Impeller (Open Vane Design)

MCM Open Vane Impeller Design is engineered to reduce turbulence, eliminate recirculation, lower radial and thrust loads and provide a smooth flow of fluid through the pump.



MCM Impeller (Semi-Open Vane)

MCM also carries semi-open vane impellers in the 5 x 6, 6 x 8 and 8 x 10 sizes.



MCM Wear Pads

The MCM housing comes with replaceable wear pads in sizes from 3 x 4 x 13 inches thru 8 x 10 x 14 inches. This feature reduces the maintenance costs of housing replacement by merely replacing the wear pads.

MCM Shearing Ring

MCM offers a shearing ring option to convert a regular 250 series pump to a shearing pump for mud applications.



MCM Mechanical Seals

MCM takes pride in carrying one of the finest mechanical seals on the market, whether it be tungsten-tungsten, tungsten-silicone or silicone-carbide. They come with a highly polished sealing face and with viton bellows and stainless steel springs



MCM Pump Bearings

MCM uses nothing but the best and the finest american SKF bearings in its pumps. The outboard bearing assembly consist of a pair of angular contact bearings with high thrust load ratings and zero end play. The heavy duty inboard bearings is a double row ball bearing with high radial load ratings to compensate for the larger size impellers and heavy duty applications.



MCM Labyrinth Seals (Optional)

MCM installs labyrinth seals by customer request in all its pumps to isolate the bearings from harmful contaminants while keeping bearing lubricated.



MCM Shaft

The MCM shaft is manufactured from the highest quality alloy steel. Designed to transmit the maximum torque with minimum shaft deflection.



MCM Shaft Sleeve

The MCM shaft sleeve is manufactured from 416 stainless steel and ceramic coated for extra life. The sleeve is designed to protect the shaft from abrasive fluids.

MCM Stuffing Box

MCM Stuffing Box cover is designed to combine the functions of the wear plate and stuffing box of conventional pumps into one piece replaceable unit. The stuffing box cover is available in two styles: for mechanical seals or for regular packing.



250 SERIES

Dimensional Outline

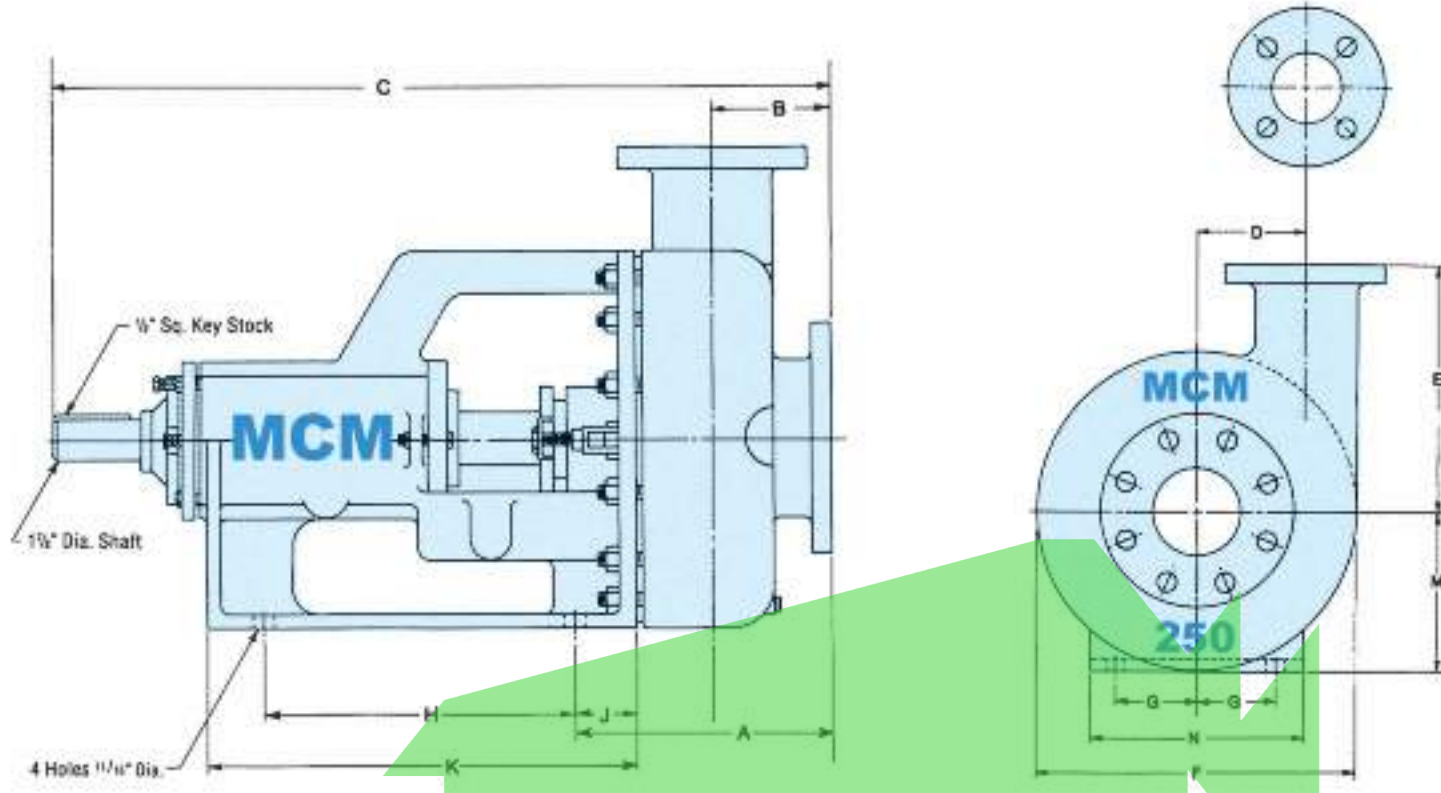

PEDESTAL, HOUSING & INSTALLATION DIMENSIONS

SIZE	A	B	C	D	E	F	G	H	J	K	M	N	Max. Imp. Diam.	Min. Imp. Diam.	Suction Size	Discharge Size	Weight Lbs.
2x3x13	8 ³ / ₄	3 ³ / ₄	33	7	10 ¹ / ₄	17 ⁷ / ₈	3 ¹ / ₂	15 ⁷ / ₁₆	2 ⁵ / ₁₆	19 ⁵ / ₈	9	9	13	6	3	2	430
3x4x13	9 ³ / ₈	4 ¹ / ₄	33 ⁵ / ₈	6 ³ / ₄	10 ¹ / ₄	17 ⁷ / ₈	3 ¹ / ₂	15 ⁷ / ₁₆	2 ⁵ / ₁₆	19 ⁵ / ₈	9	9	13	6	4	3	440
4x5x14	10 ³ / ₄	5	35	6 ¹ / ₈	11	19	3 ¹ / ₂	15 ⁷ / ₁₆	2 ⁵ / ₁₆	19 ⁵ / ₈	9	9	14	7	5	4	490
5x6x11	12 ¹ / ₁₆	5 ³ / ₄	36 ³ / ₈	6	11	17 ⁷ / ₈	3 ¹ / ₂	15 ⁷ / ₁₆	2 ⁵ / ₁₆	19 ⁵ / ₈	9	9	11	8	6	5	520
5x6x14	12 ¹ / ₁₆	5 ³ / ₄	36 ³ / ₈	6	11	21	3 ¹ / ₂	15 ⁷ / ₁₆	2 ⁵ / ₁₆	19 ⁵ / ₈	9	9	14	10	6	5	550
6x8x11	13 ¹ / ₄	6 ³ / ₄	37 ¹ / ₂	8 ³ / ₈	14	20	3 ¹ / ₂	15 ⁷ / ₁₆	2 ⁵ / ₁₆	19 ⁵ / ₈	9	9	11	8	8	6	610
6x8x14	13 ¹ / ₄	6 ³ / ₄	37 ¹ / ₂	8 ³ / ₈	14	23	3 ¹ / ₂	15 ⁷ / ₁₆	2 ⁵ / ₁₆	19 ⁵ / ₈	9	9	14	10	8	6	630

FLANGE SIZES

FLANGE SIZE	I.D.	O.D.	B.C.	NO. OF HOLES	SIZE OF HOLES	THICKNESS
2	2	6	4 ³ / ₄	4	3/4	5/8
3	3	7 ¹ / ₂	6	4	3/4	3/4
4	4	9	7 ¹ / ₂	8	3/4	15/16
5	5	10	8 ¹ / ₂	8	7/8	15/16
6	6	11	9 ¹ / ₂	8	7/8	1
8	8	13 ¹ / ₂	11 ³ / ₄	8	7/8	1 ¹ / ₈

MCM... The Pump Manufacturing Company!!

250 SERIES

Performance Curves

COMPOSITE CURVE 1150 RPM

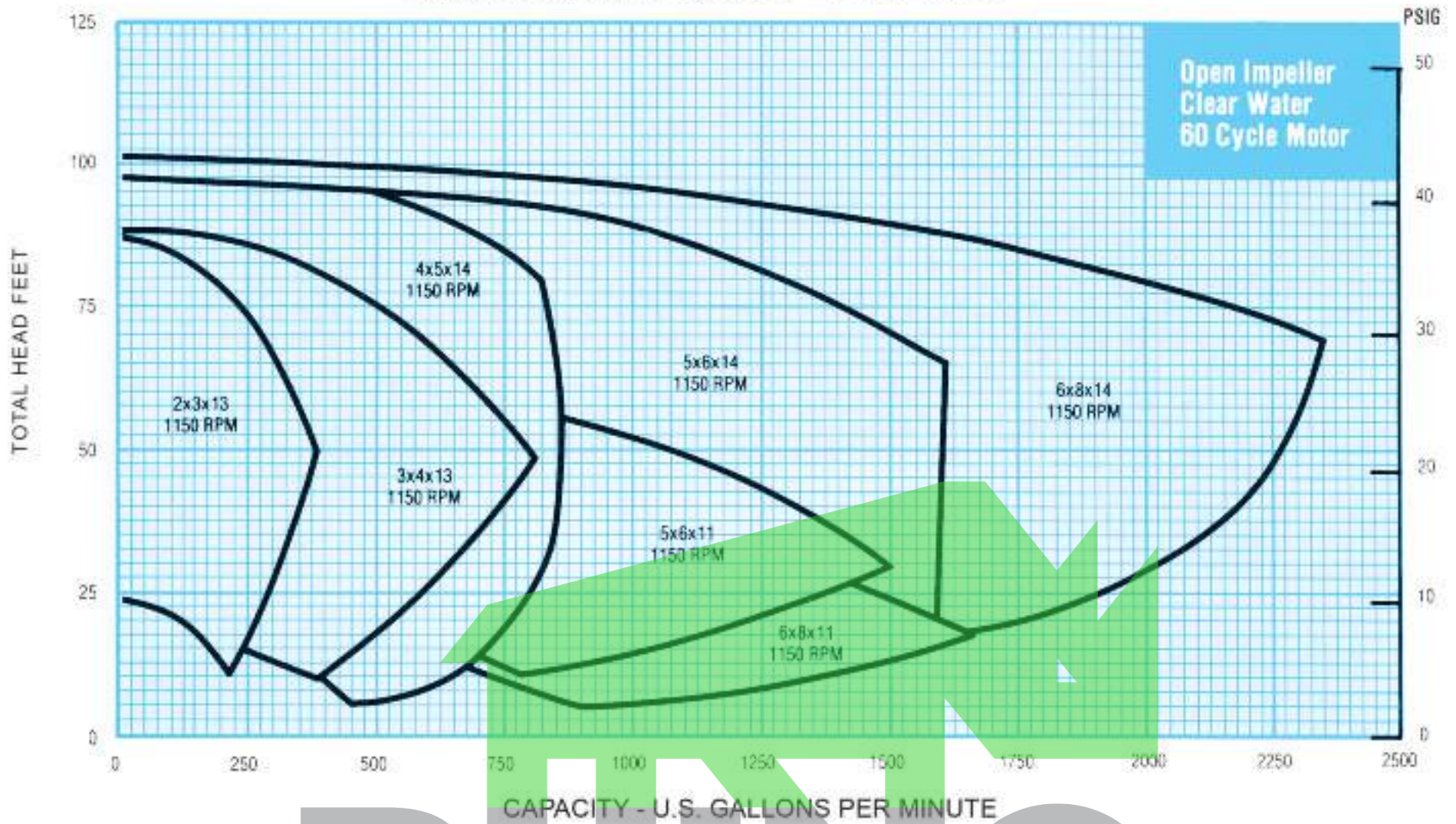

COMPOSITE CURVE 1750-3500 RPM

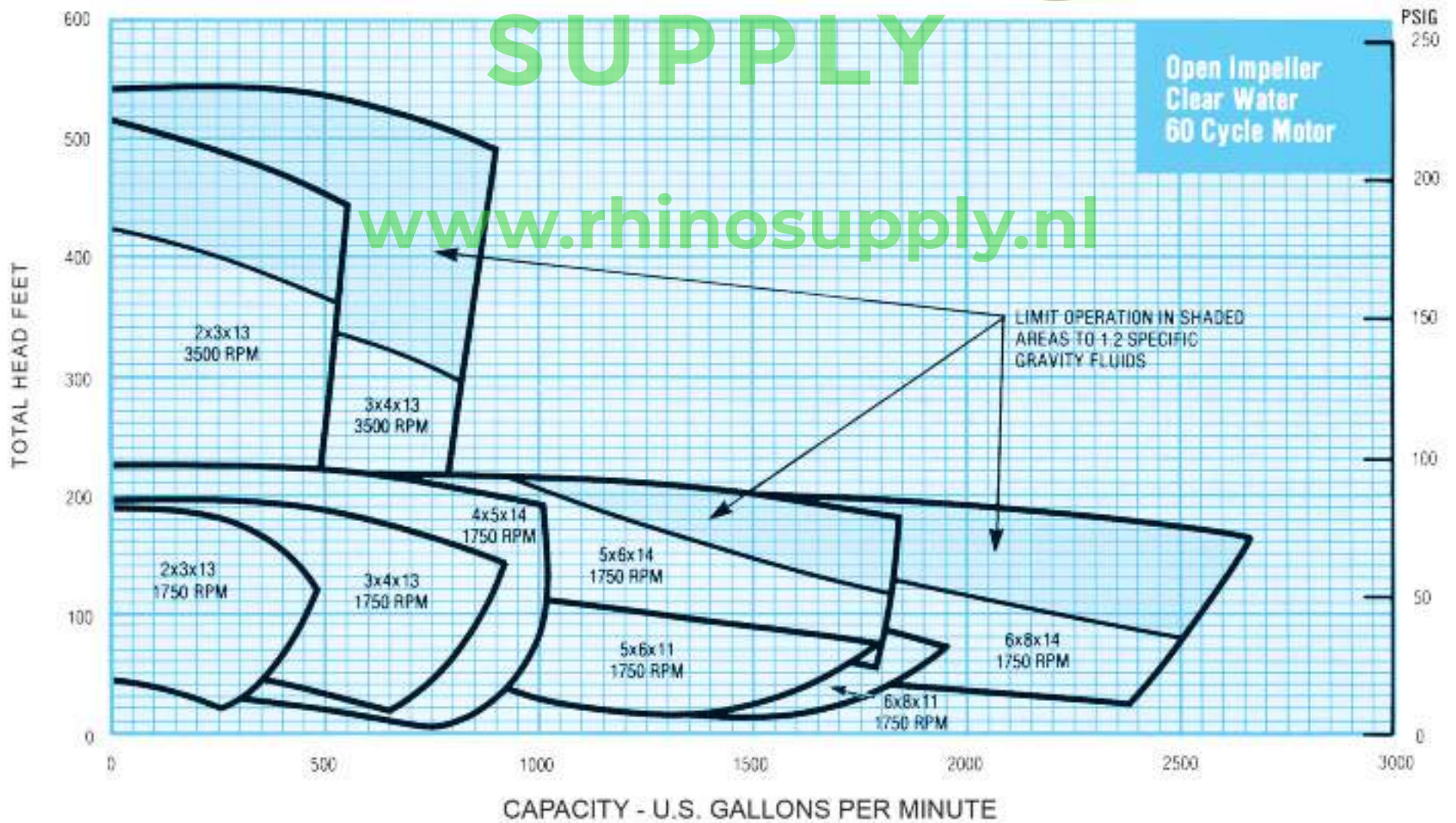

Curves show performance with clear water. If specific gravity is other than 1.0, curve HP must be corrected.

2 x 3 x 13 1150 RPM

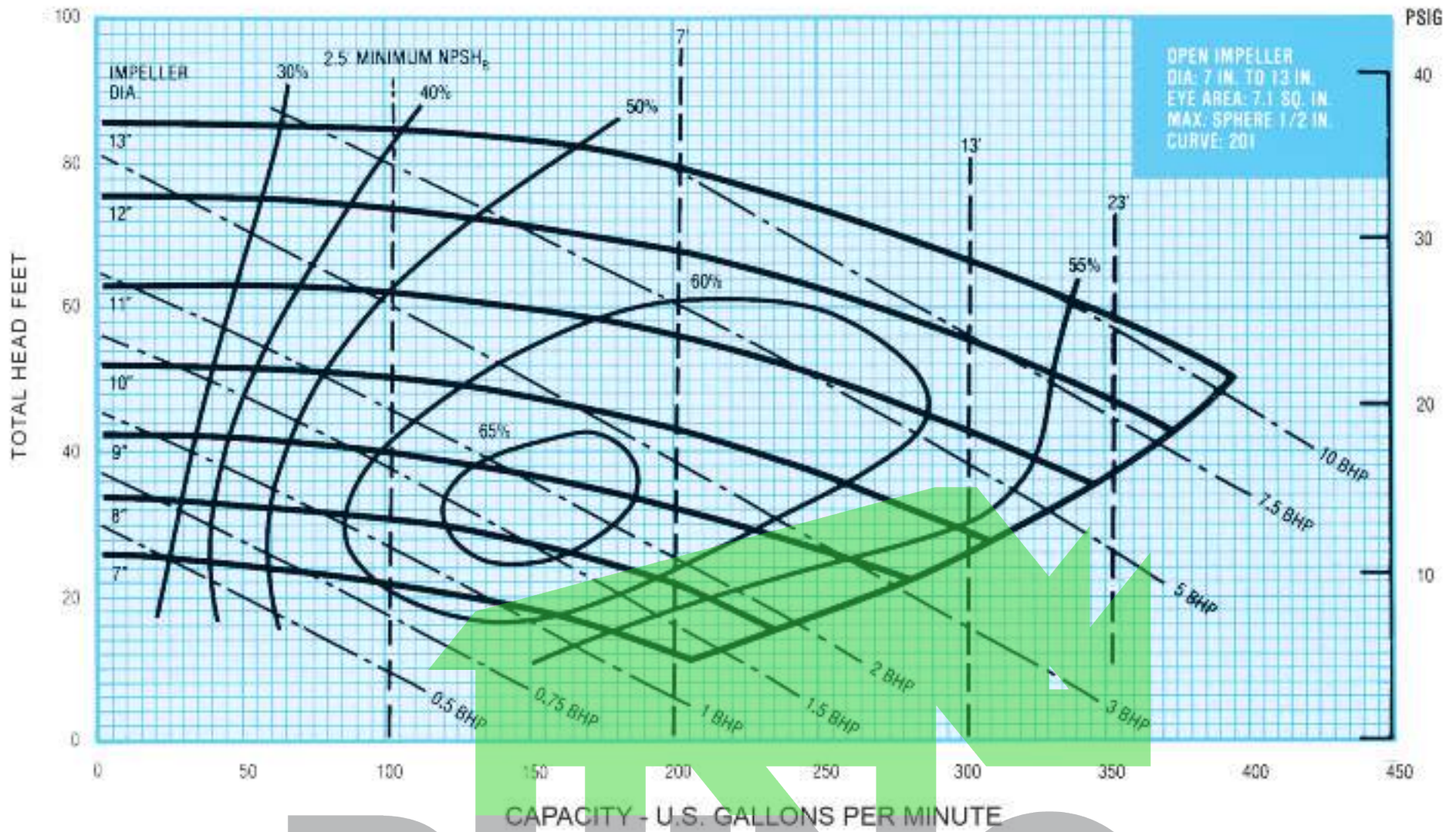

RHINO

2 x 3 x 13 1750 RPM

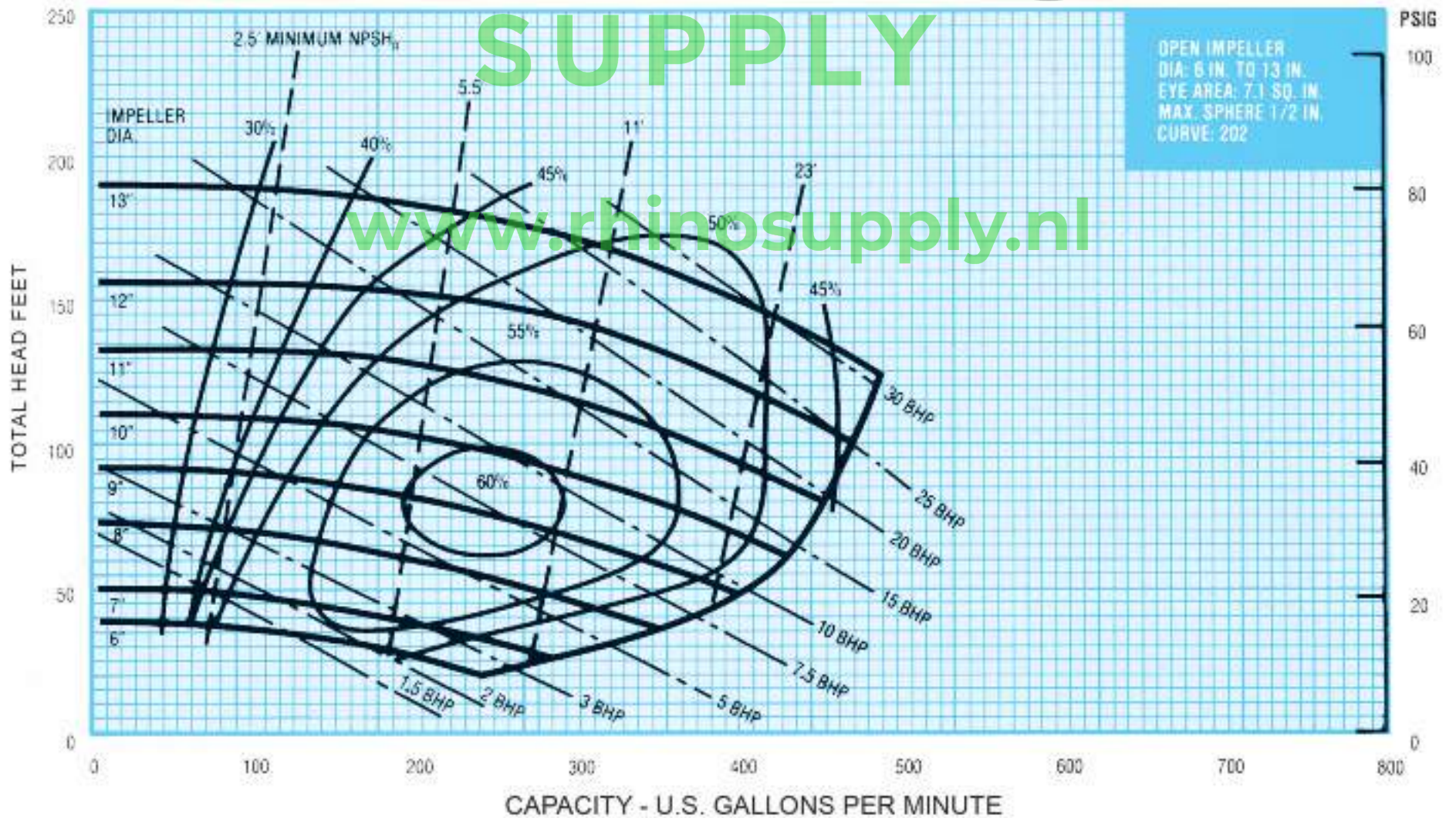

www.rhinosupply.nl

Curves show performance with clear water. If specific gravity is other than 1.0, curve HP must be corrected.

250 SERIES



2 x 3 x 13 3500 RPM

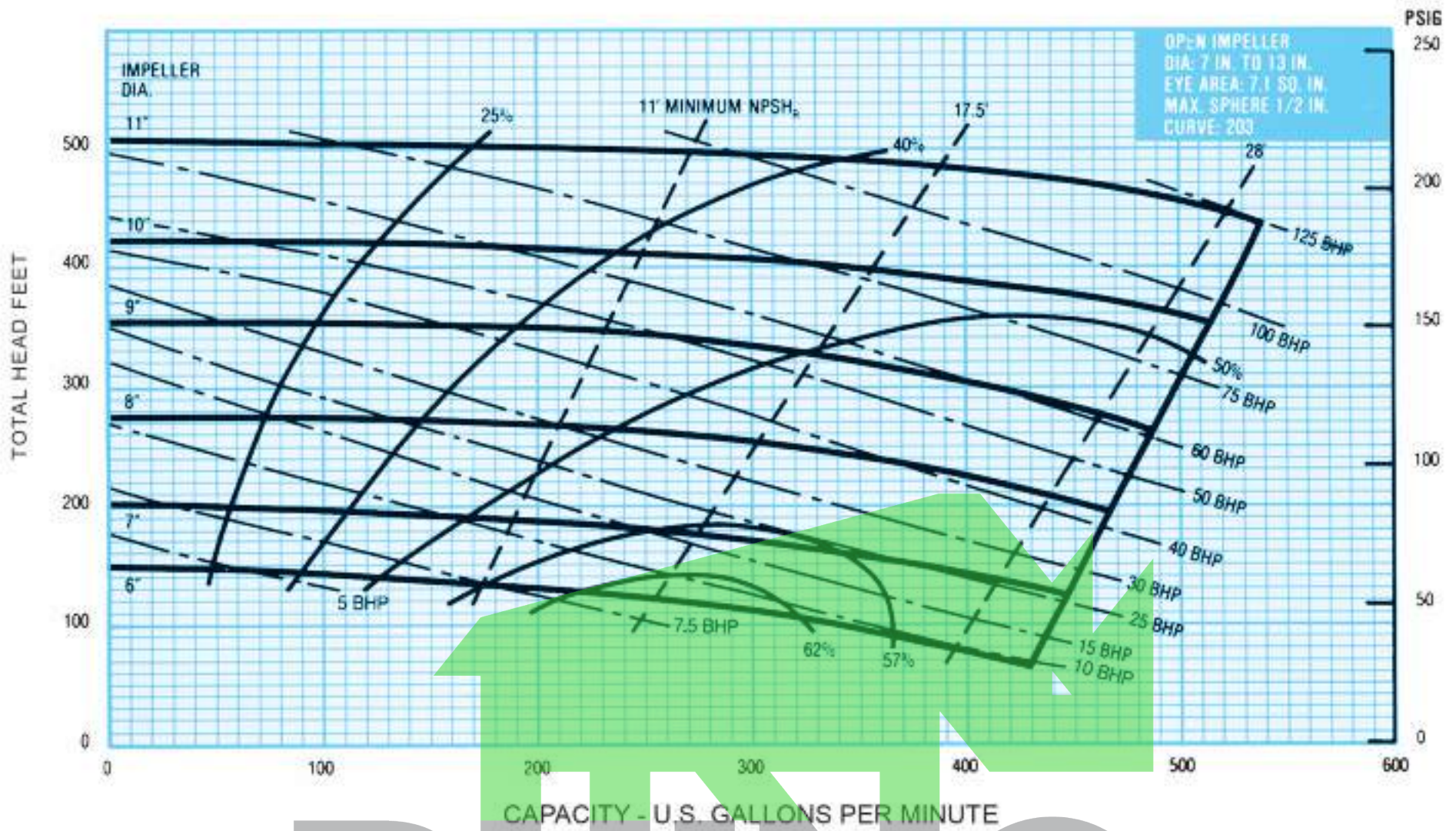

RHINO
2 x 3 x 13 700-2500 RPM

SUPPLY

www.rhinosupply.nl

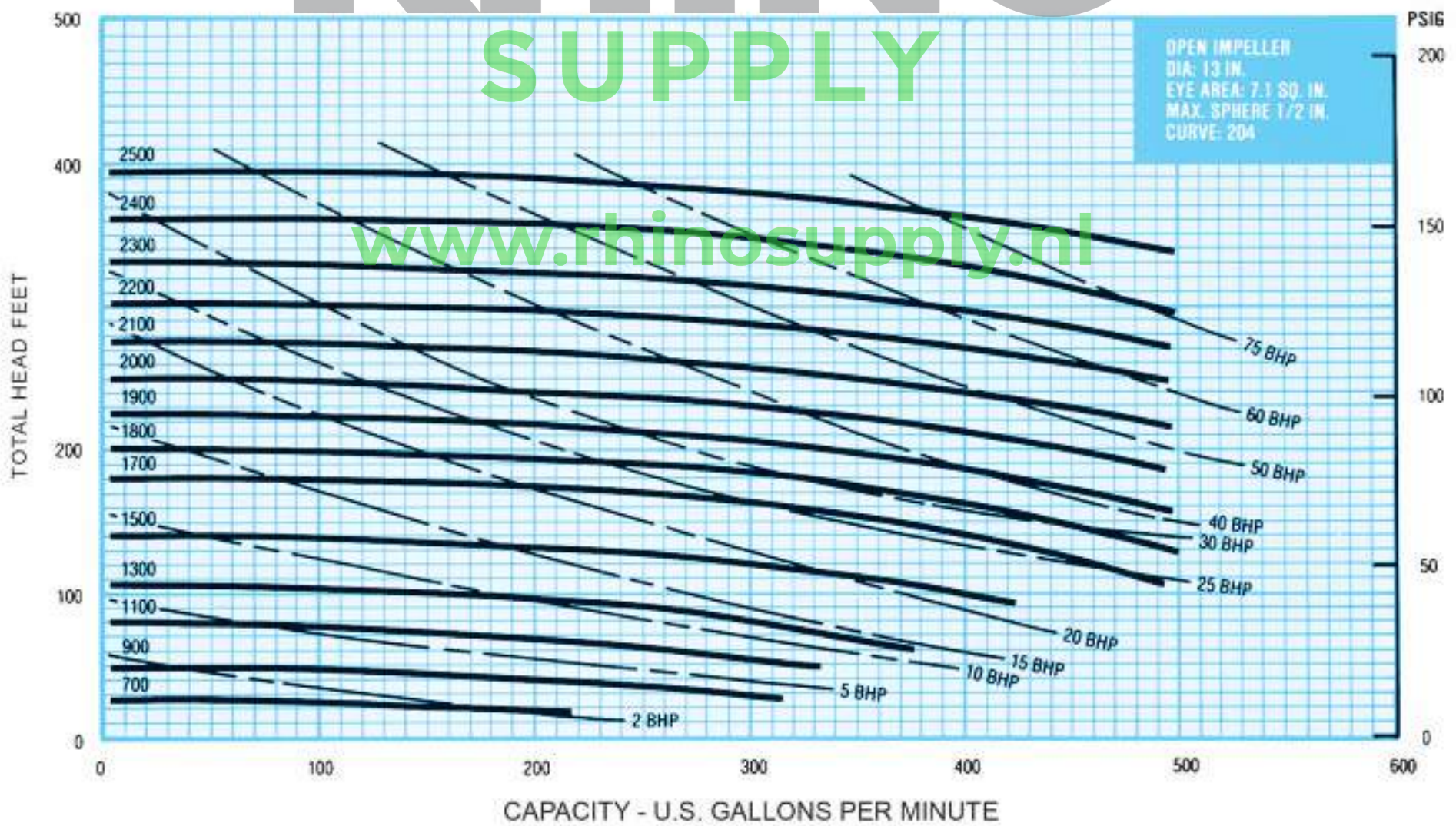

Curves show performance with clear water. If specific gravity is other than 1.0, curve HP must be corrected.

3 x 4 x 13 1150 RPM

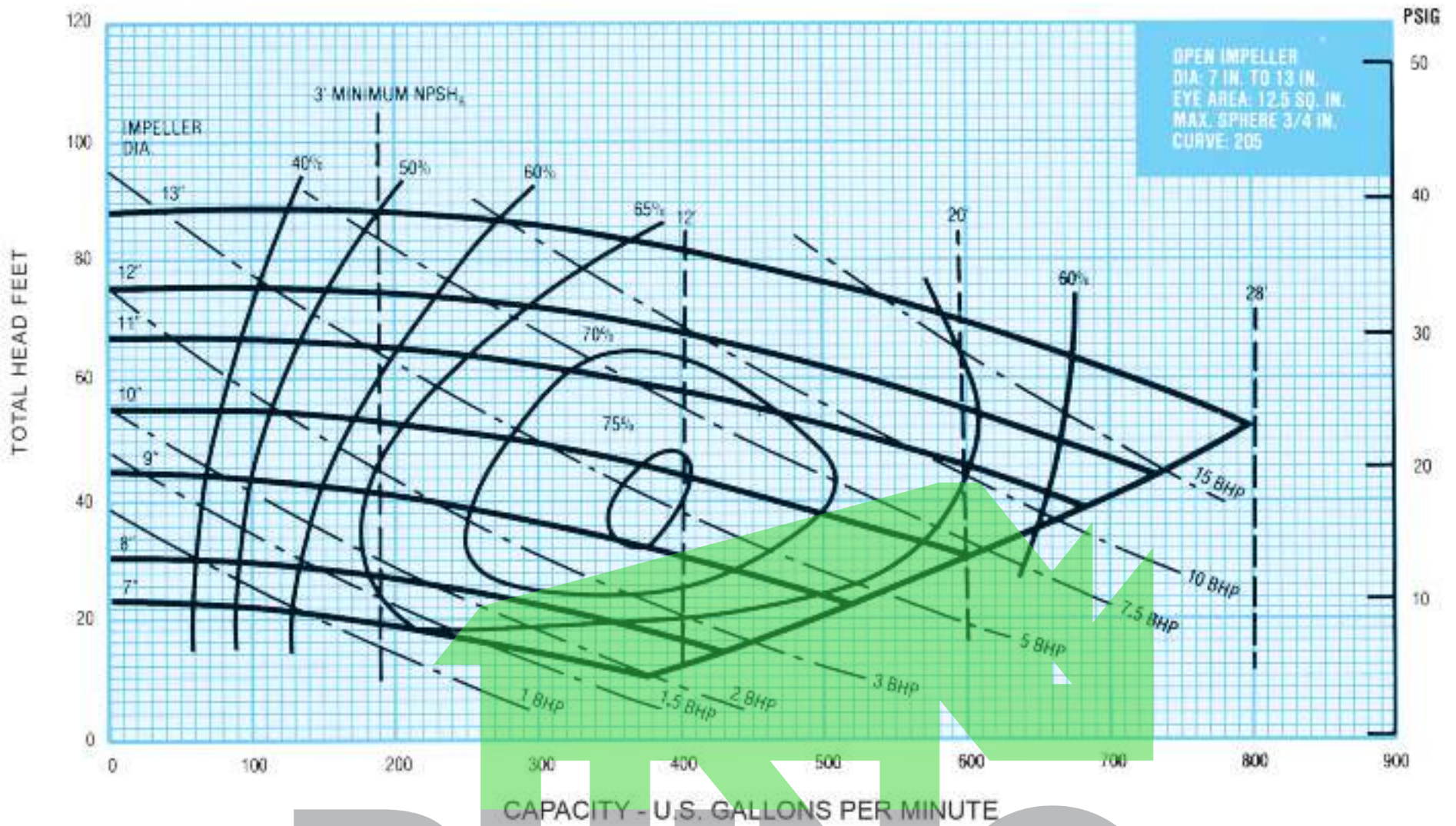

RHINO

3 x 4 x 13 1750 RPM

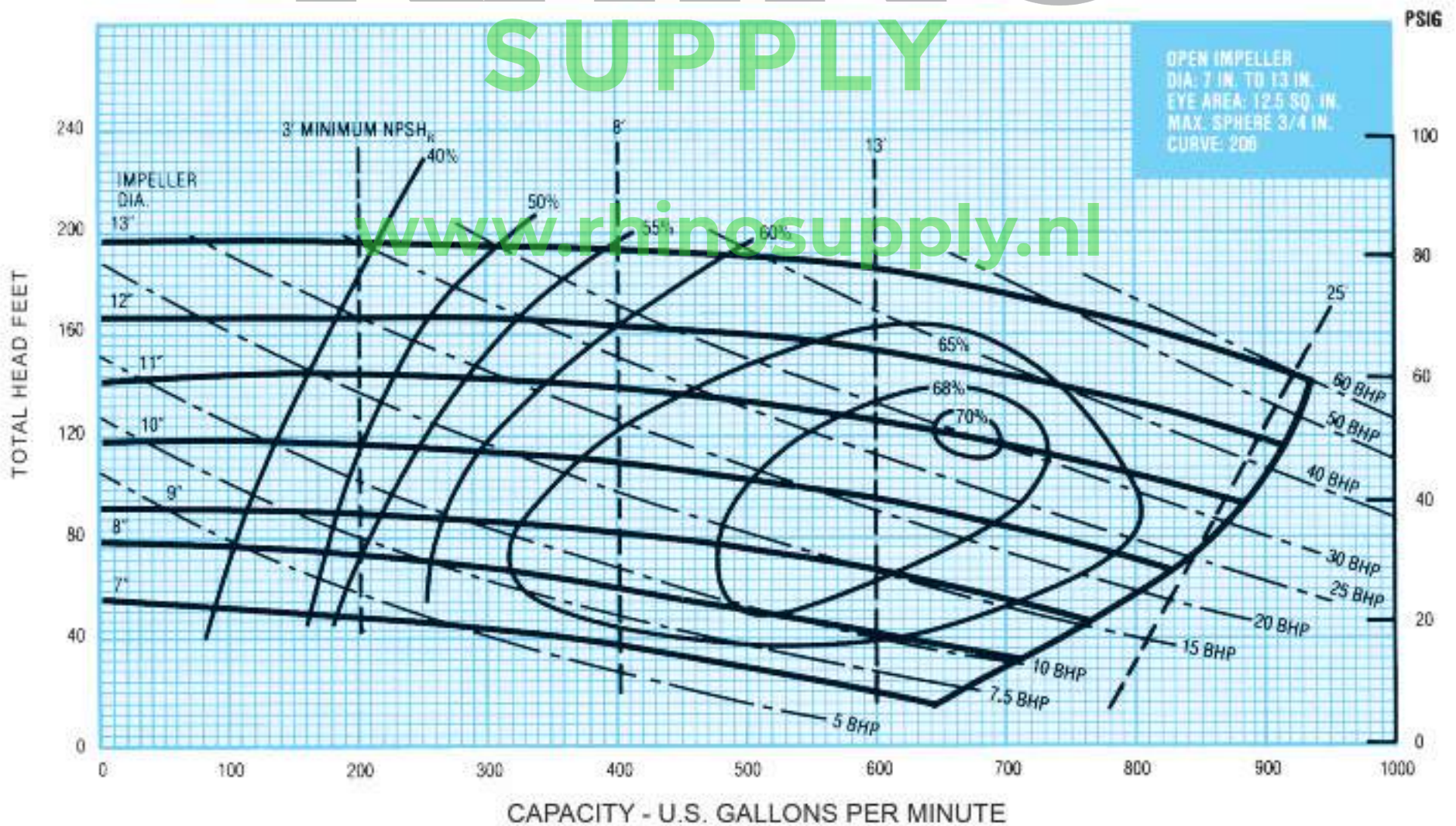

www.rhinosupply.nl

Curves show performance with clear water. If specific gravity is other than 1.0, curve HP must be corrected.

250 SERIES



3 x 4 x 13 3500 RPM

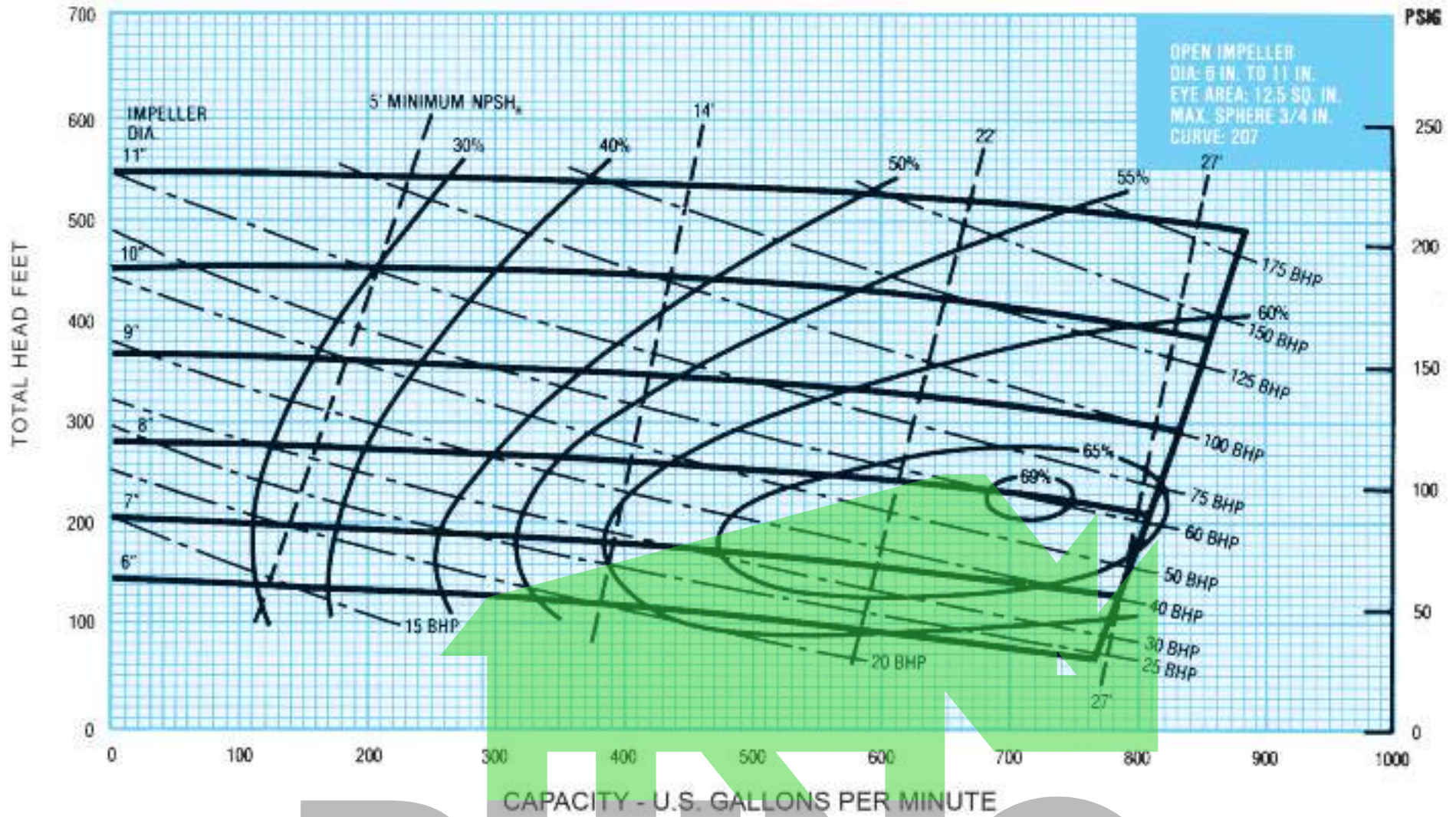

RHINO
SUPPLY

3 x 4 x 13 1000-2400 RPM

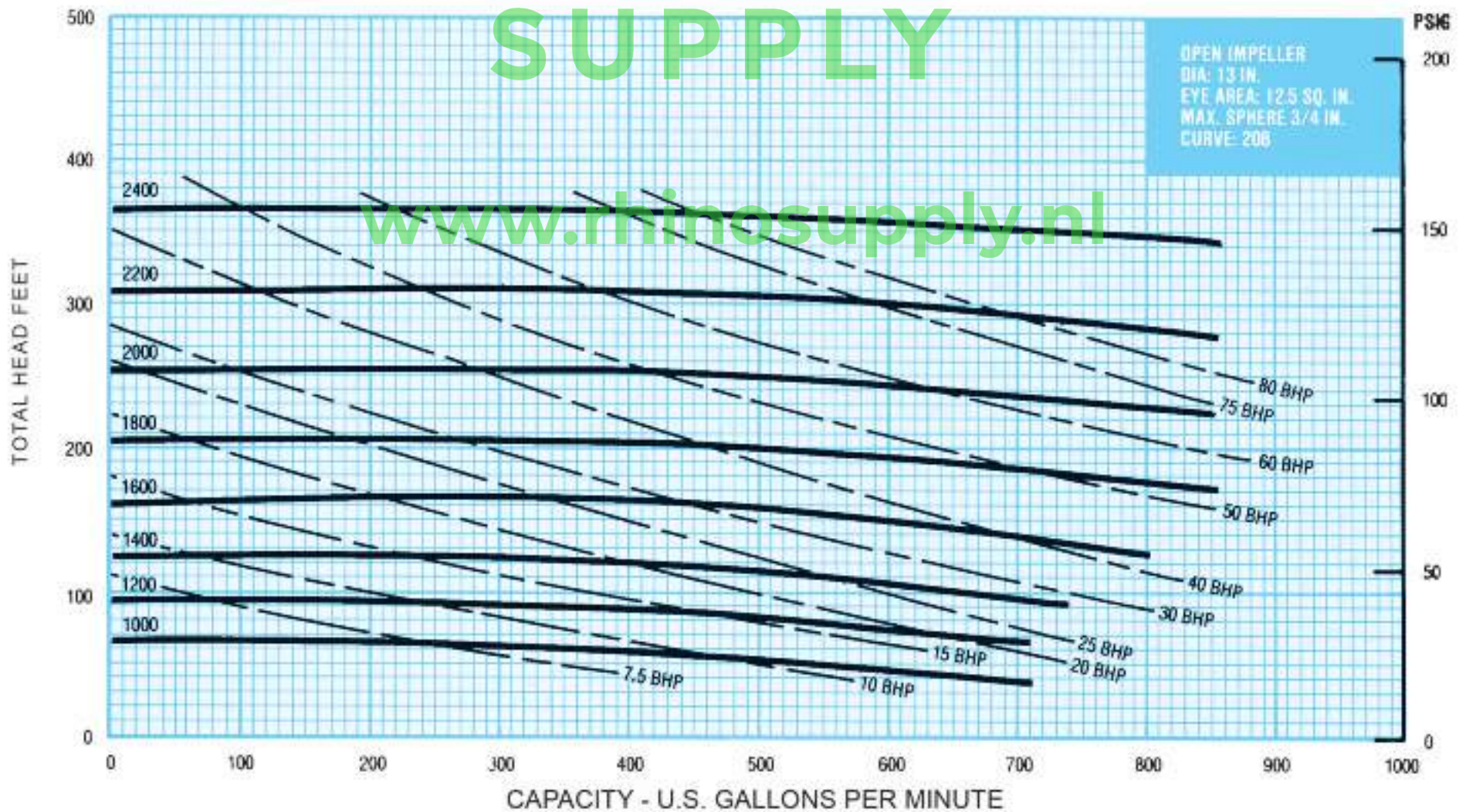

Curves show performance with clear water. If specific gravity is other than 1.0, curve HP must be corrected.

4 x 5 x 14 1150 RPM

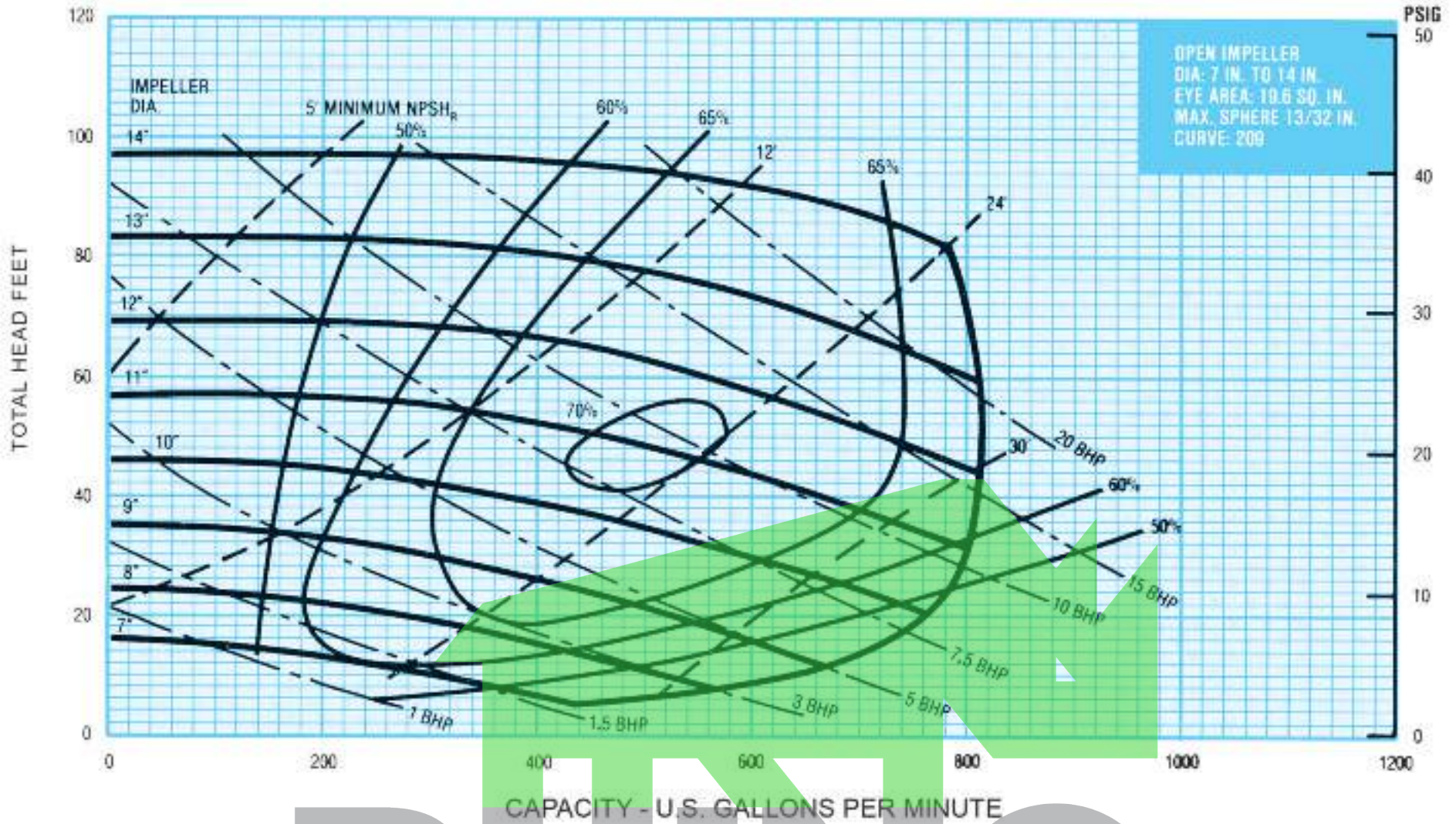

RHINO

4 x 5 x 14 1750 RPM

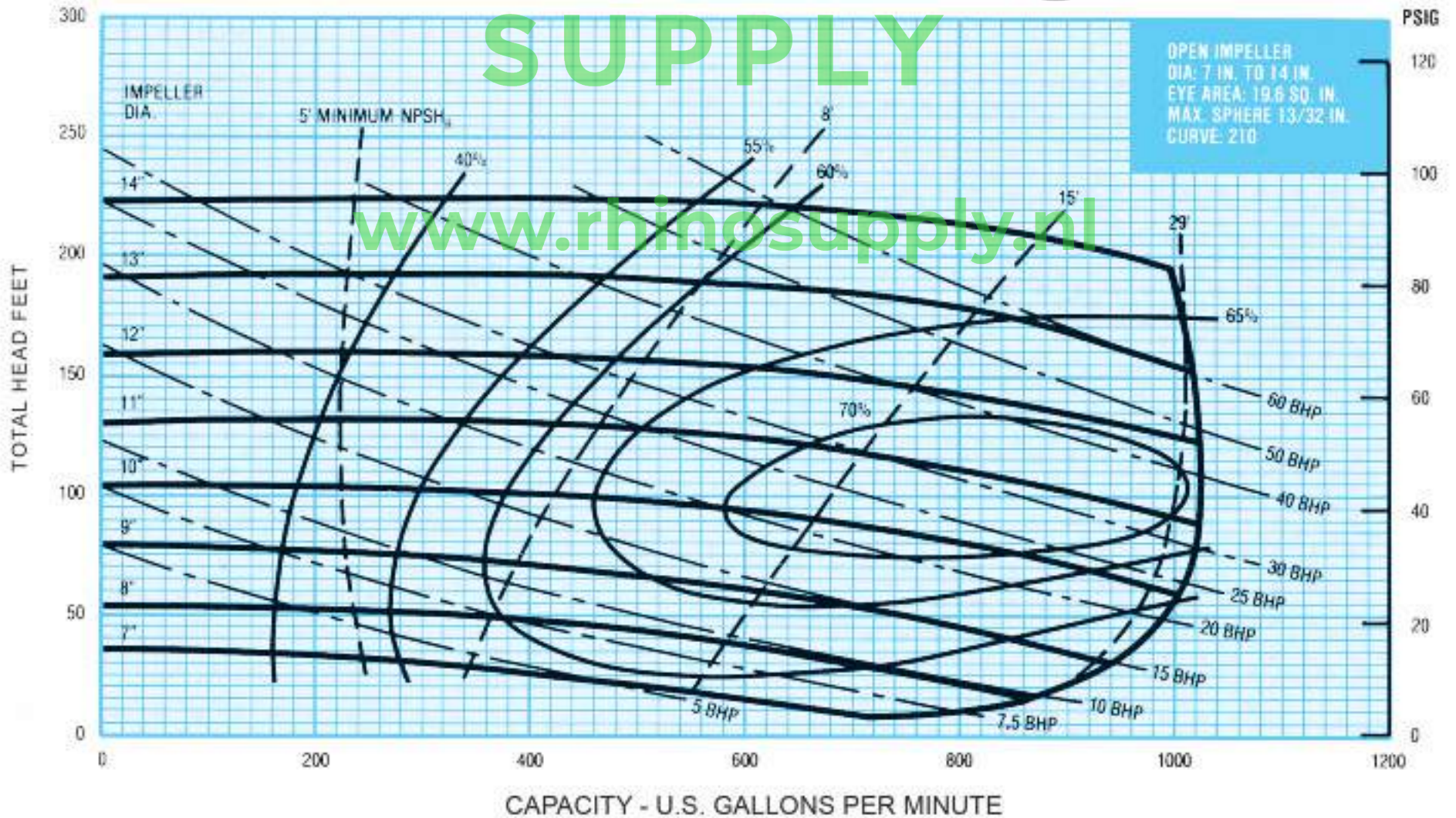

Curves show performance with clear water. If specific gravity is other than 1.0, curve HP must be corrected.

250 SERIES



4 x 5 x 14 800-2100 RPM

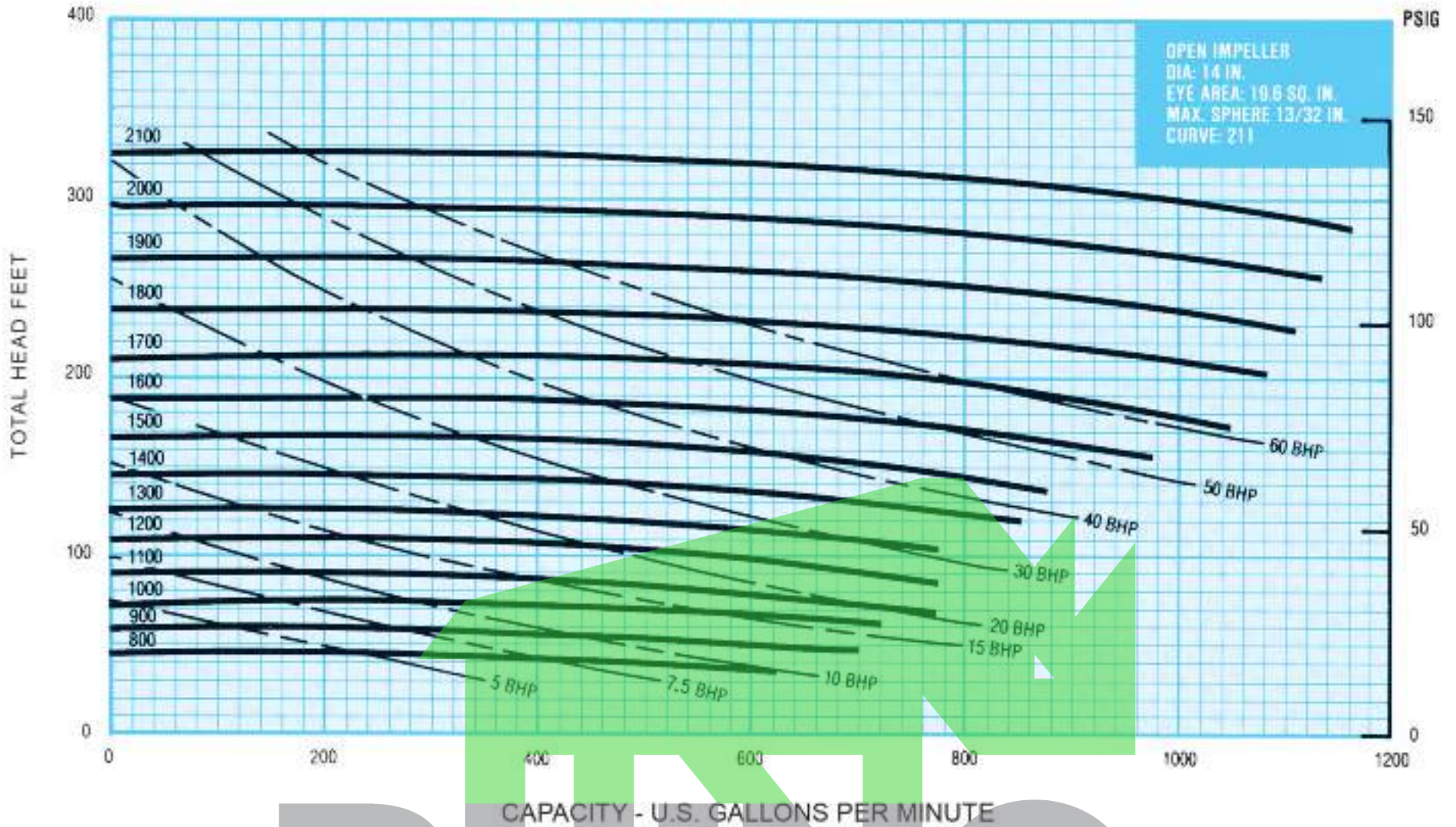

RHINO
SUPPLY

5 x 6 x 11 1150 RPM

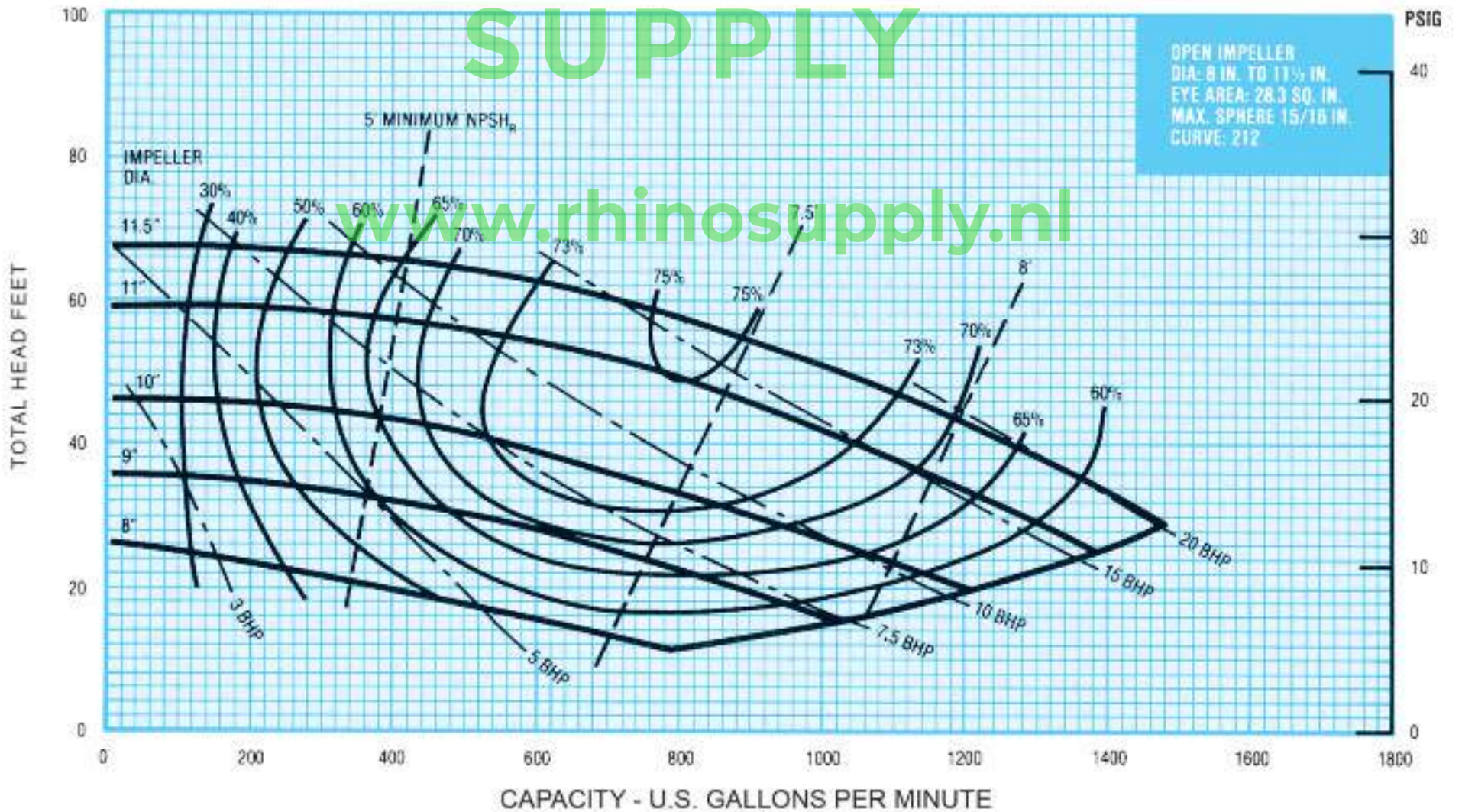

Curves show performance with clear water. If specific gravity is other than 1.0, curve HP must be corrected.

5 x 6 x 11 1750 RPM

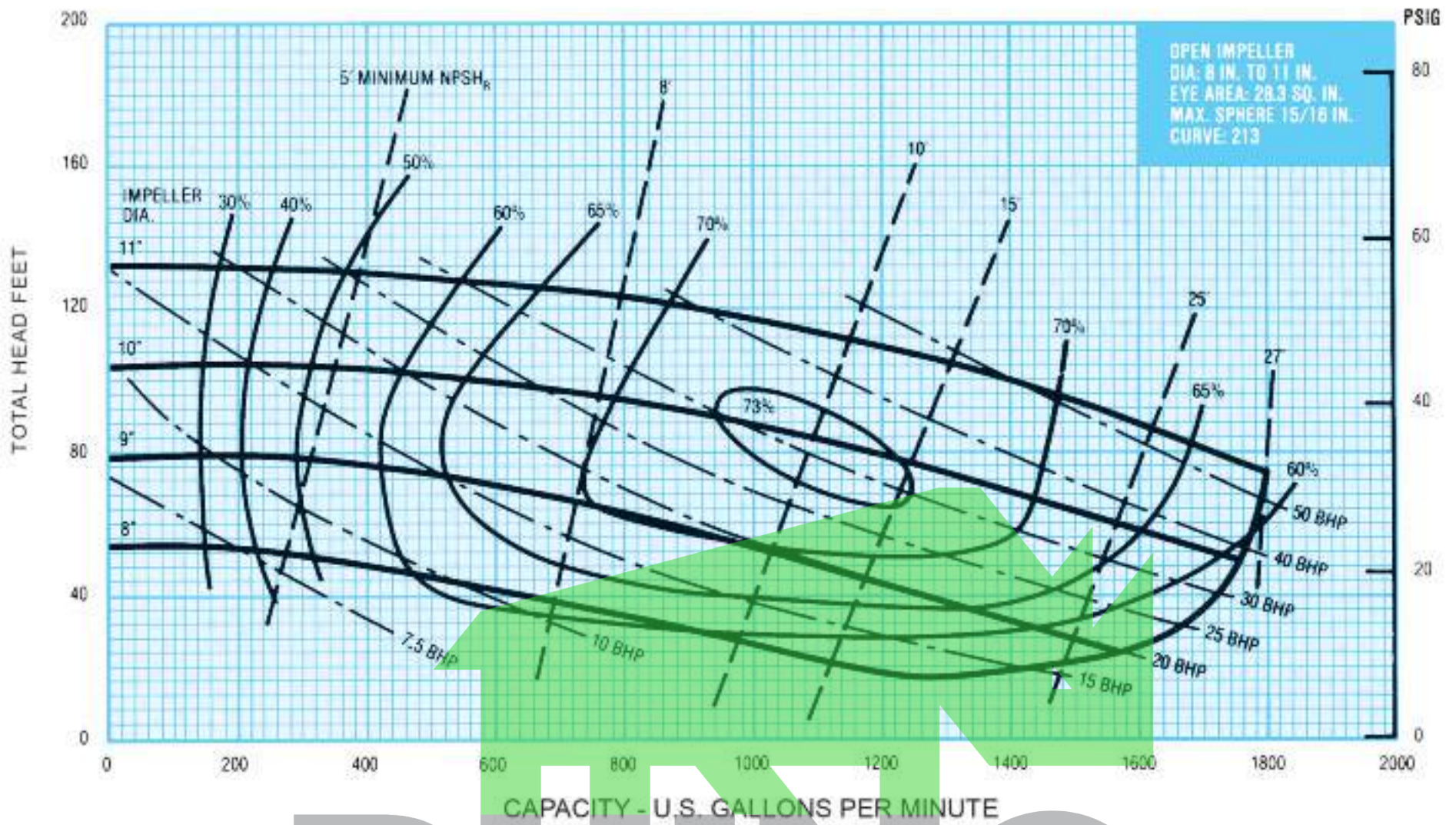

RHINO
SUPPLY

5 x 6 x 11 800-1900 RPM

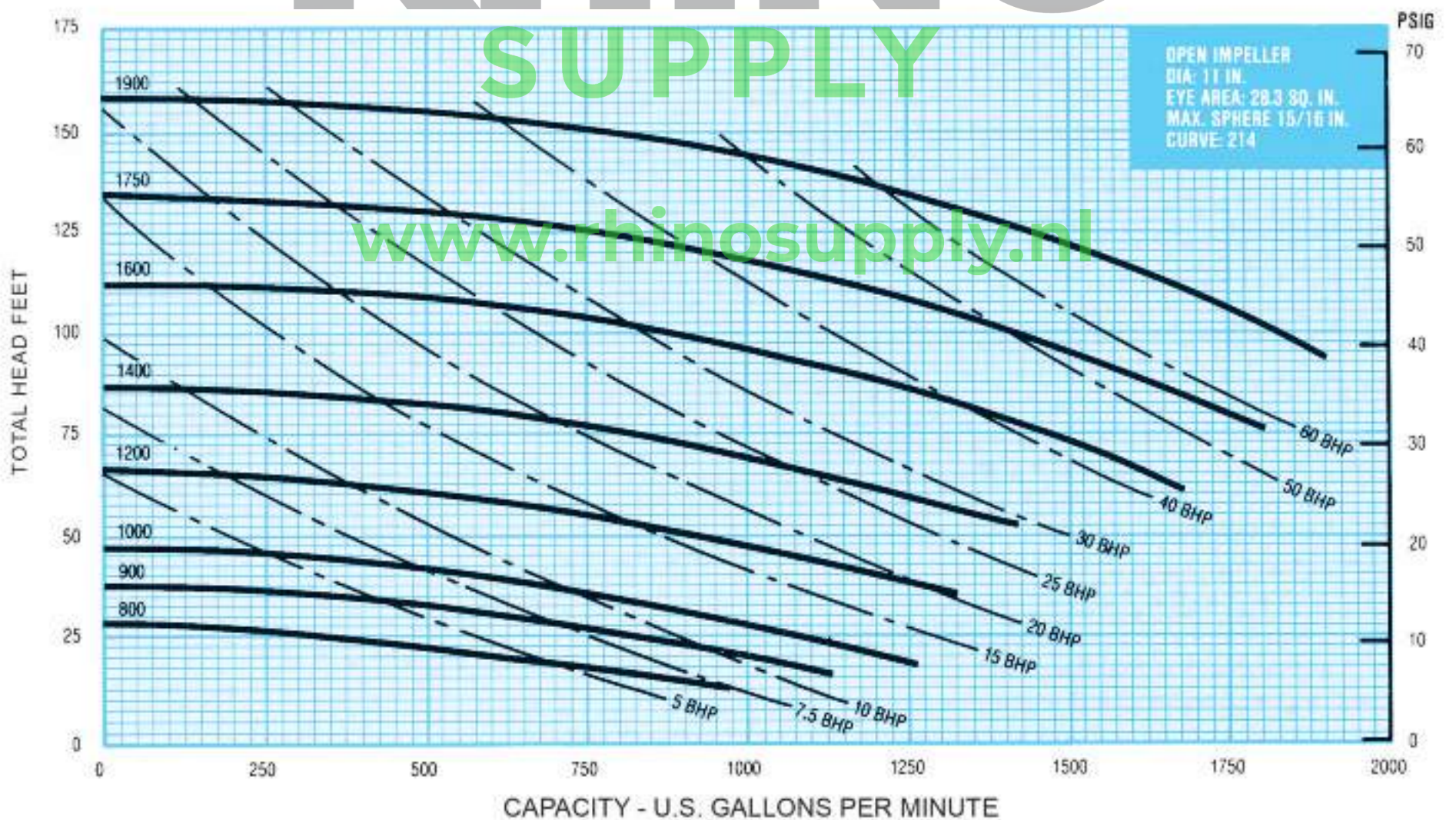

Curves show performance with clear water. If specific gravity is other than 1.0, curve HP must be corrected.

250 SERIES



5 x 6 x 14 1150 RPM

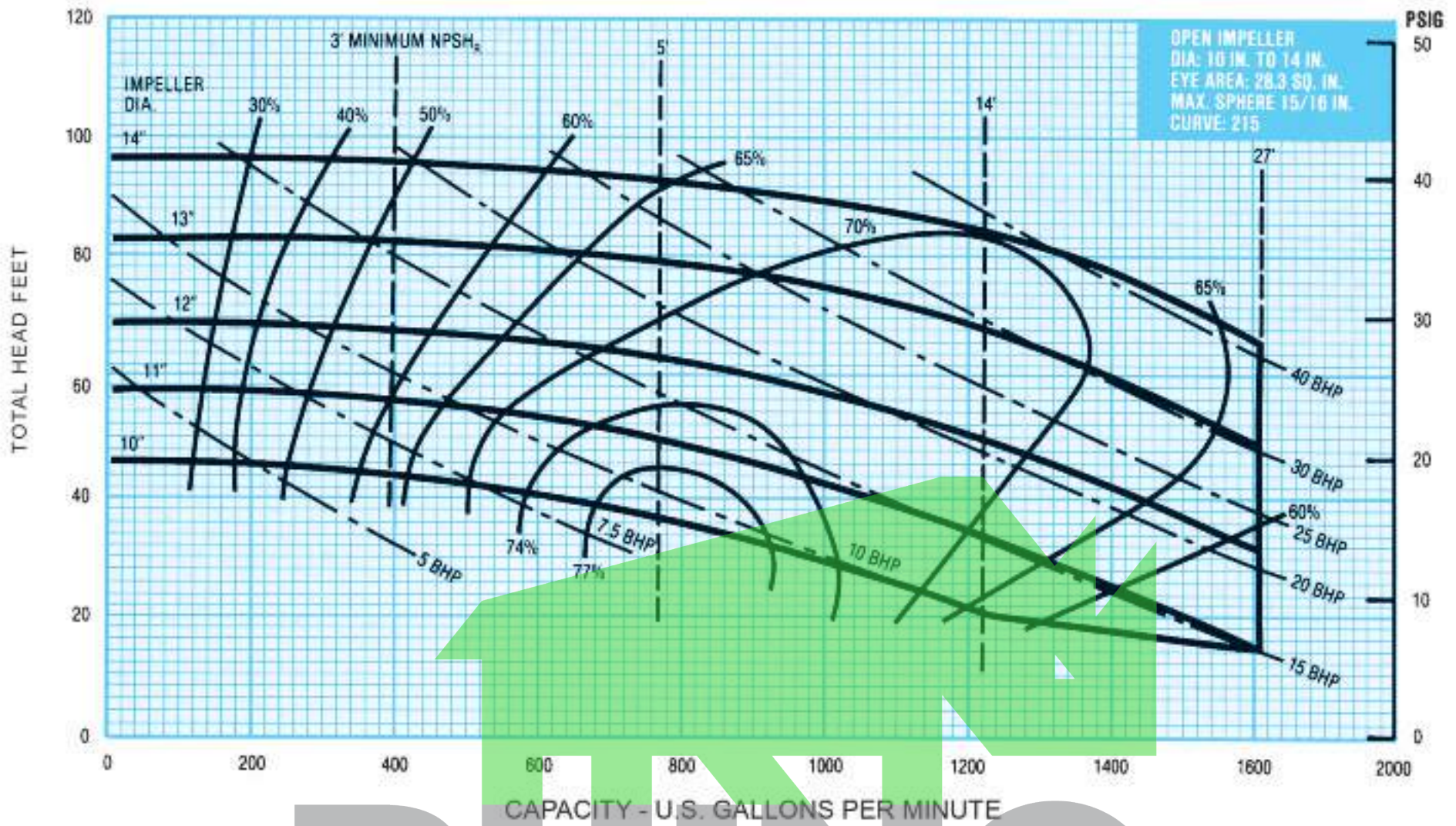

RHINO

5 x 6 x 14 1750 RPM

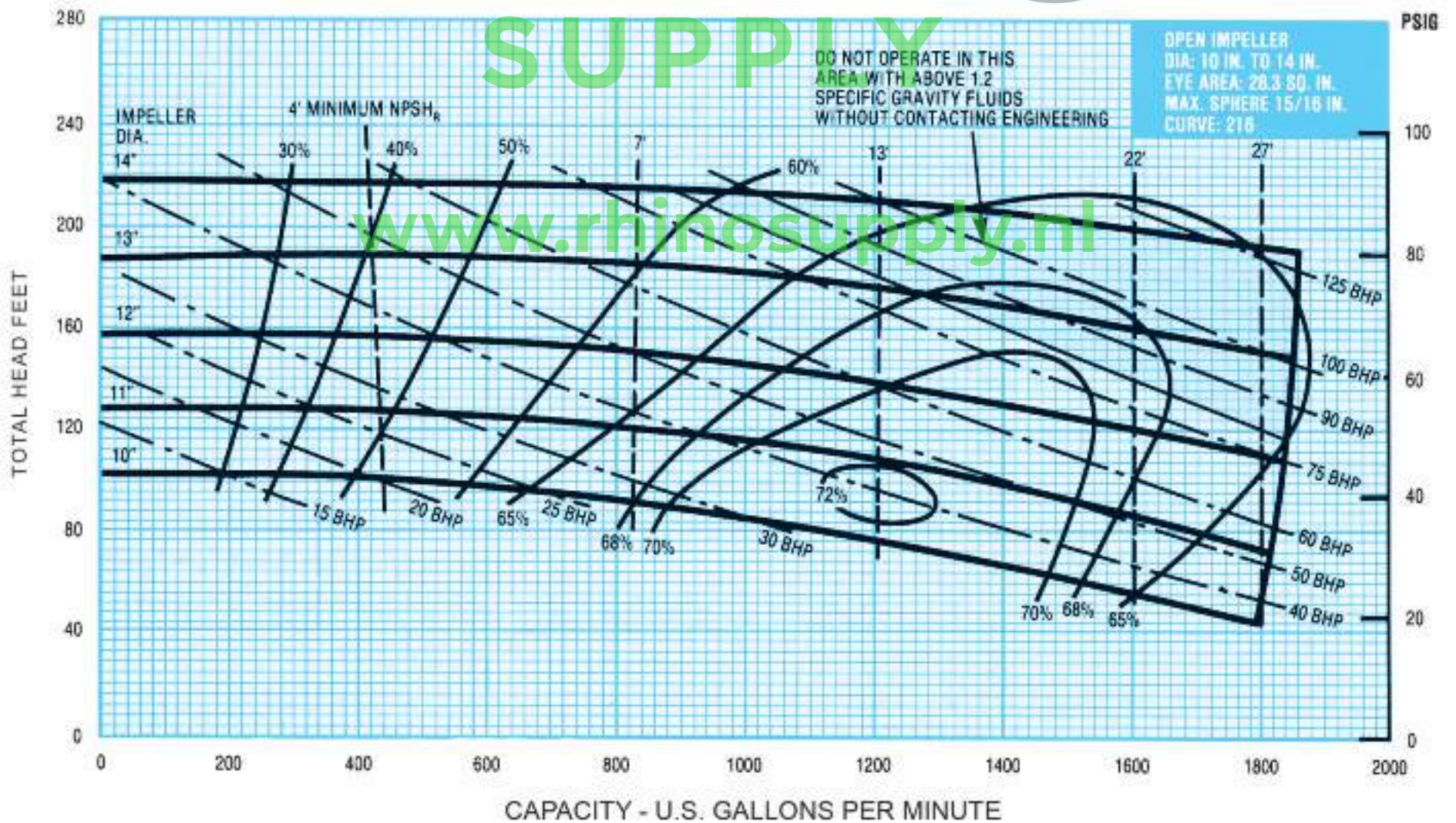

Curves show performance with clear water. If specific gravity is other than 1.0, curve HP must be corrected.

5 x 6 x 14 800-1800 RPM

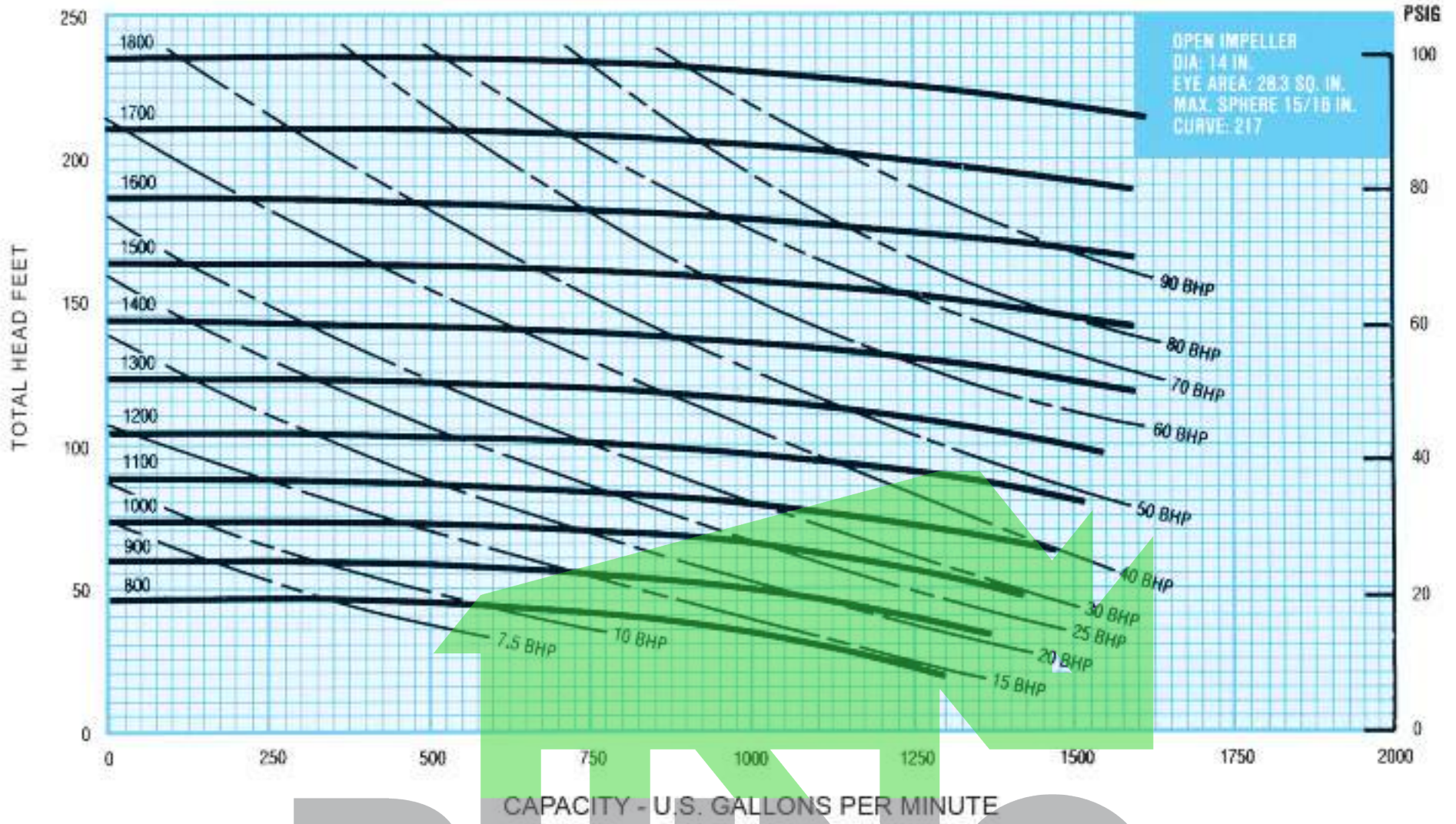

RHINO
SUPPLY

6 x 8 x 11 1150 RPM

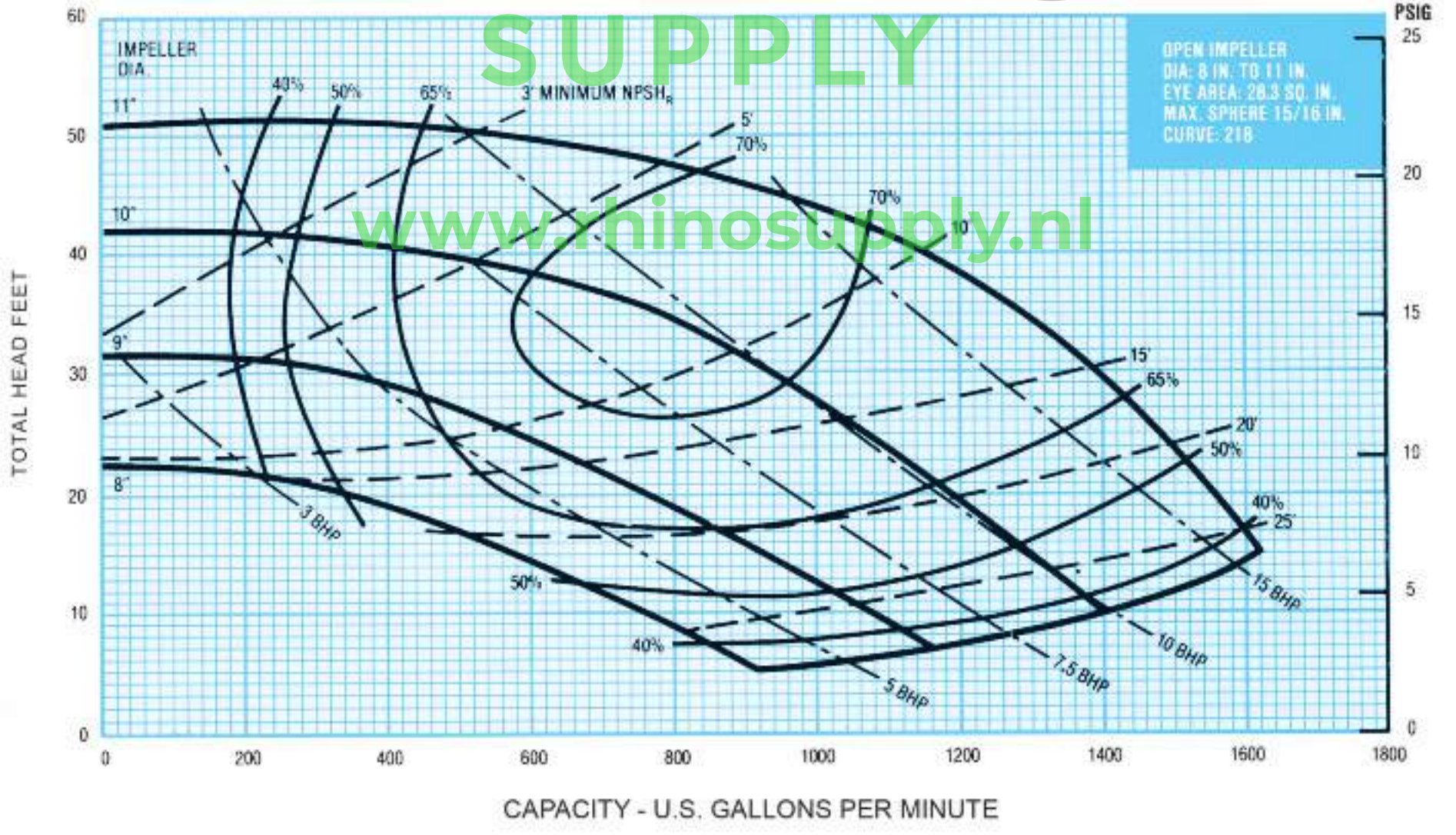

Curves show performance with clear water. If specific gravity is other than 1.0, curve HP must be corrected.

6 x 8 x 11 1750 RPM

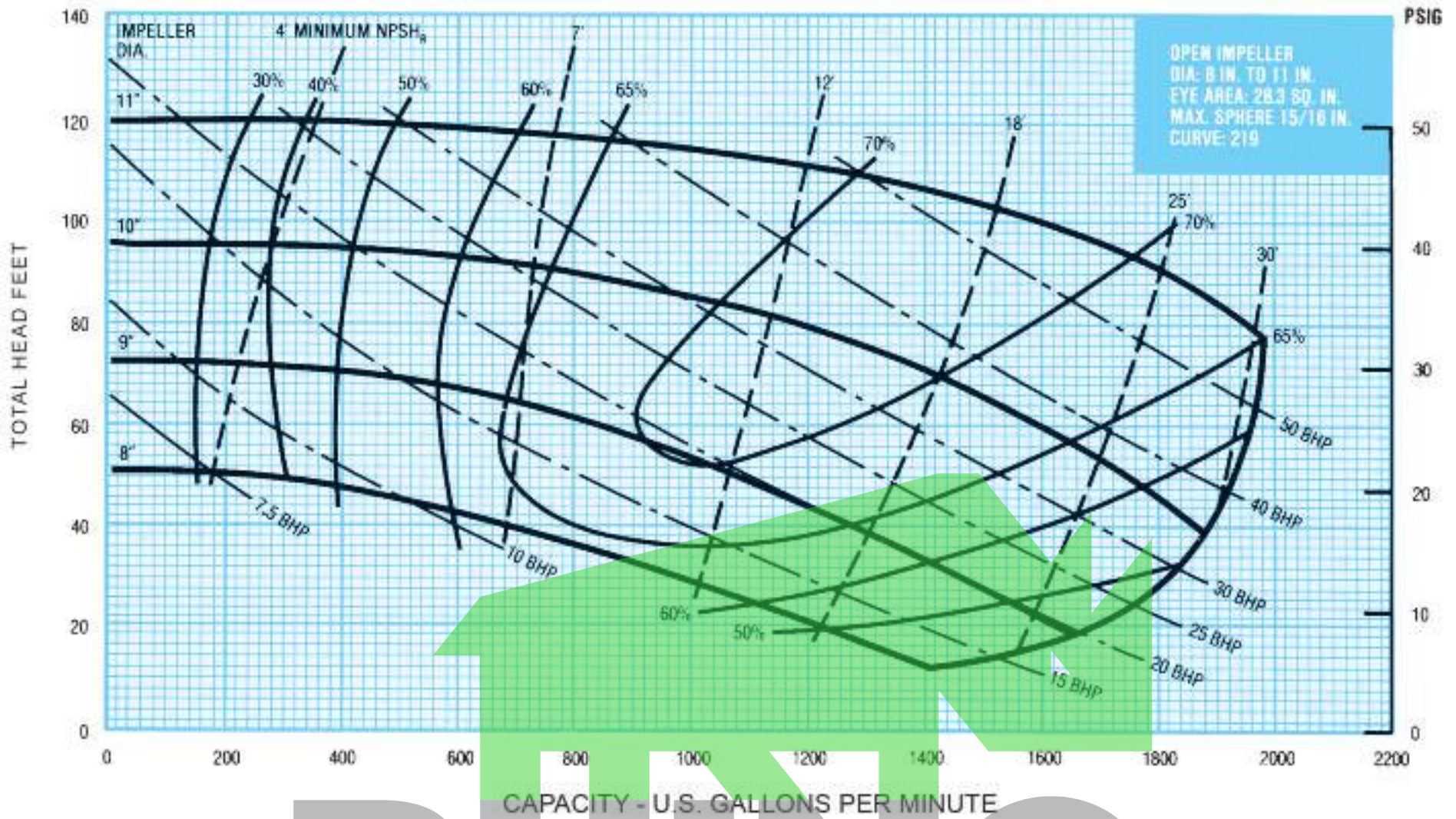

RHINO
6 x 8 x 11 800-1800 RPM

SUPPLY

www.rhinosupply.nl

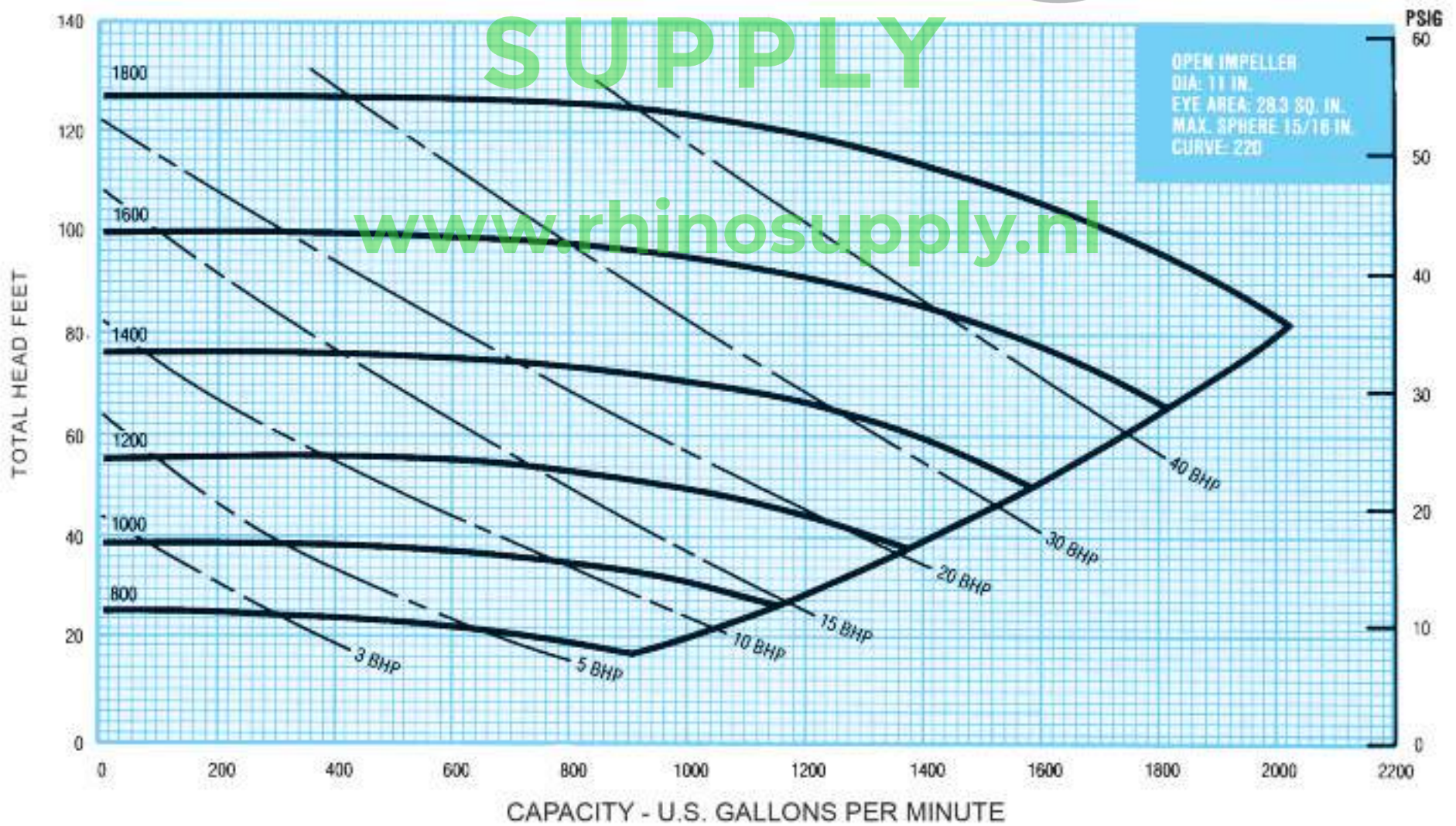

Curves show performance with clear water. If specific gravity is other than 1.0, curve HP must be corrected.

250 SERIES



6 x 8 x 14 1150 RPM

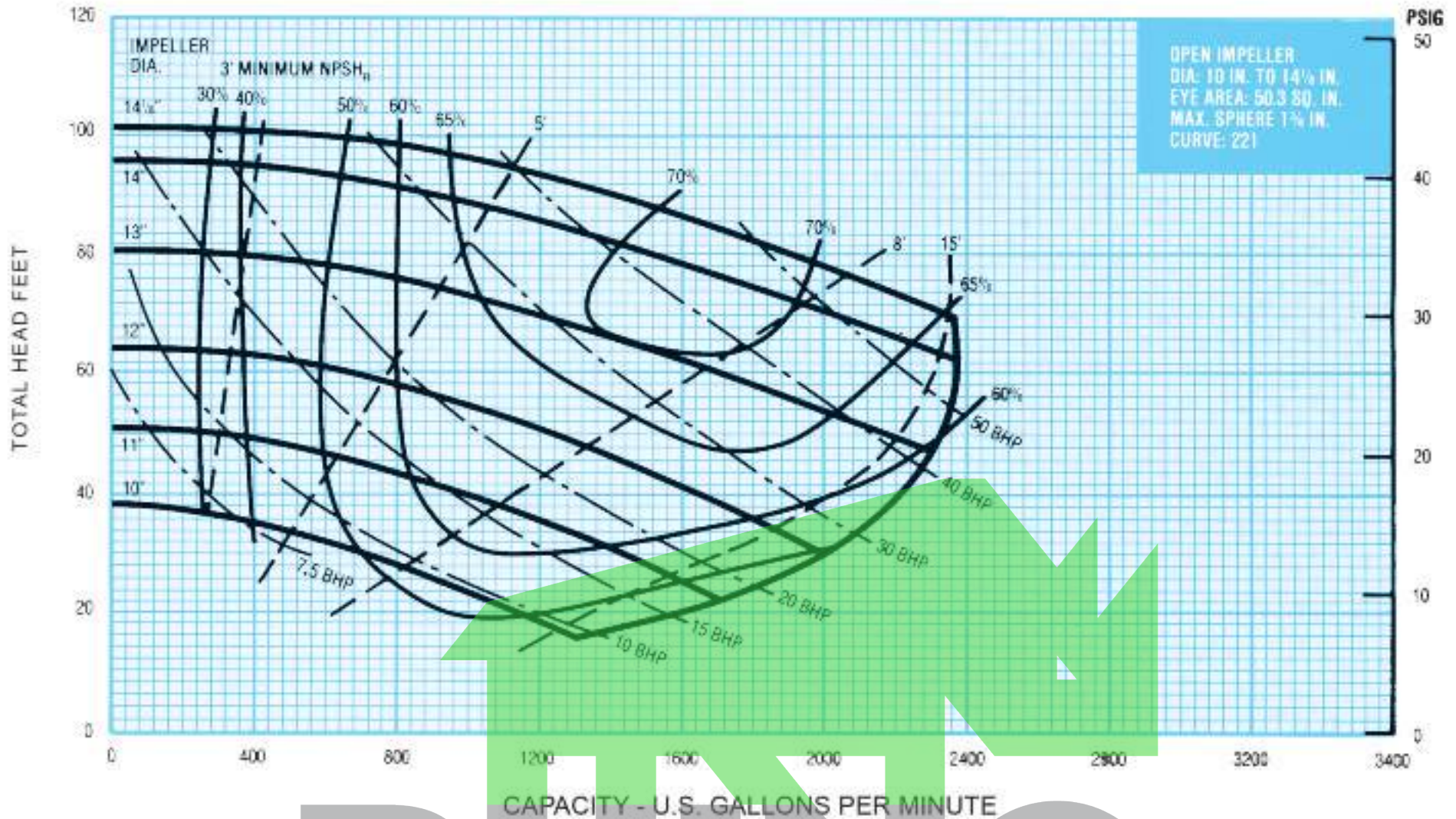

RHINO

6 x 8 x 14 1750 RPM

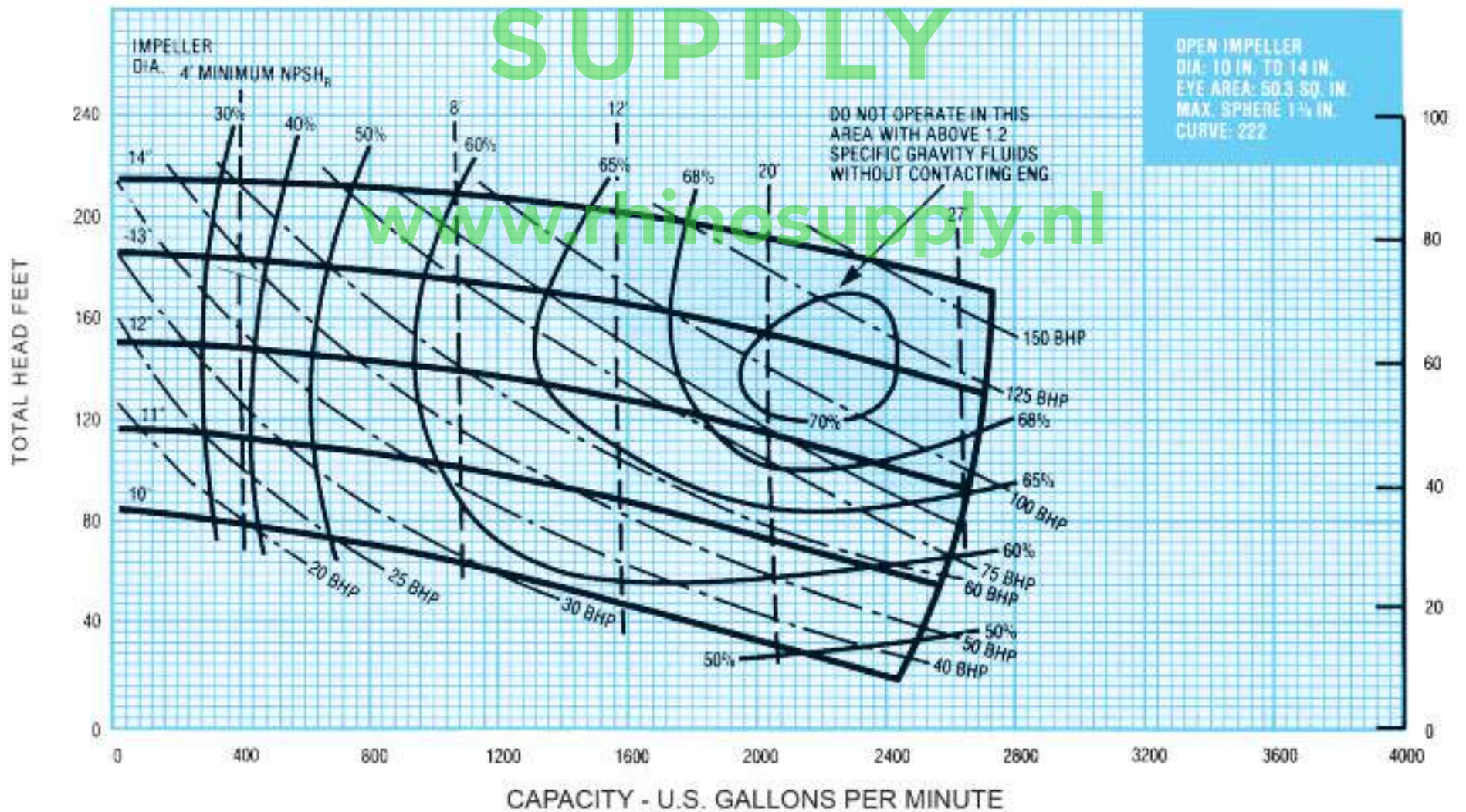

www.rhinosupply.nl

Curves show performance with clear water. If specific gravity is other than 1.0, curve HP must be corrected.

250 SERIES



6 x 8 x 14 800-1700 RPM

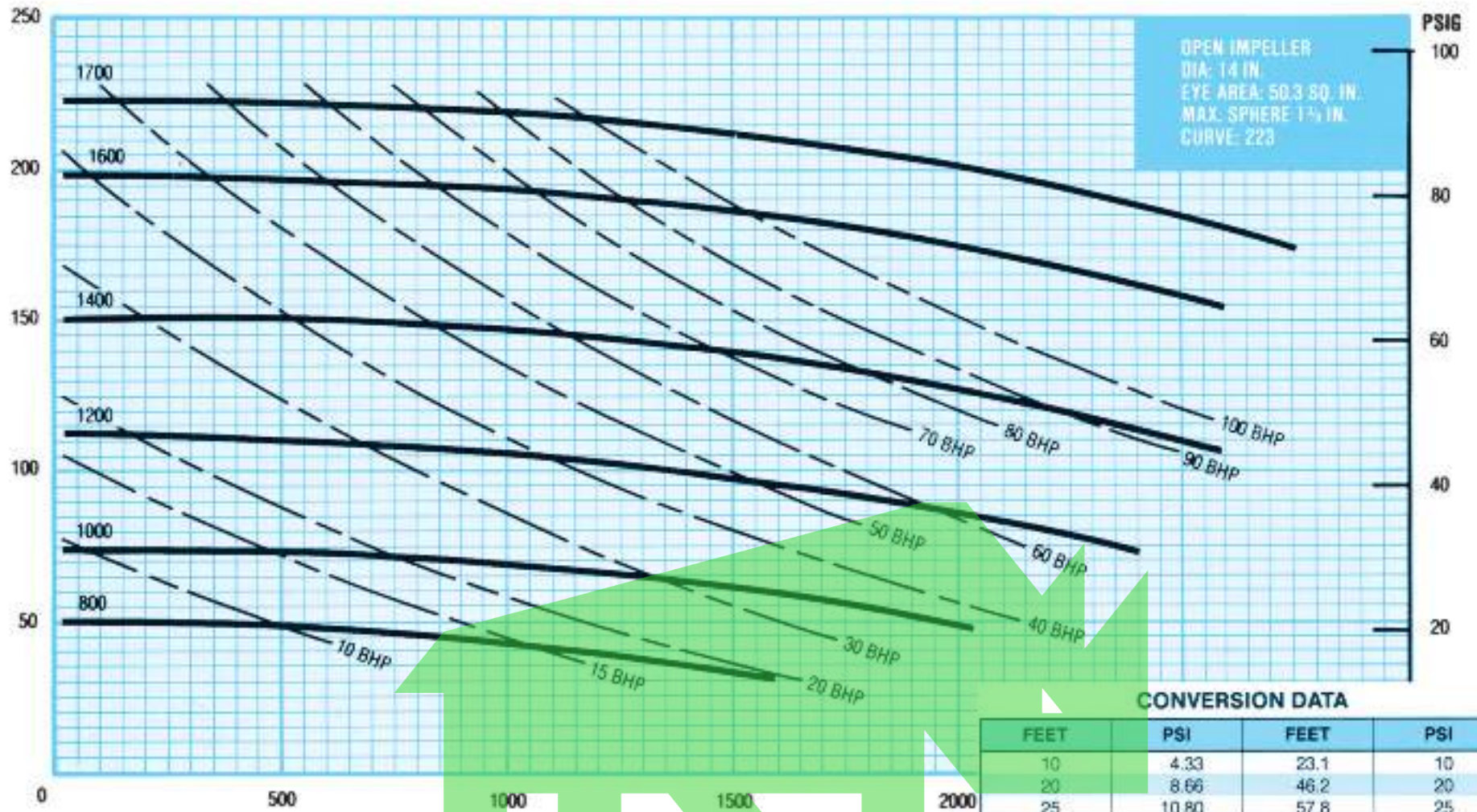

CONVERSION DATA

FEET	PSI	FEET	PSI
10	4.33	23.1	10
20	8.66	46.2	20
25	10.80	57.8	25
30	13.00	69.3	30
40	17.30	80.9	35
50	21.60	92.4	40
75	32.48	104.0	45
100	43.20	115.5	50
150	64.80	138.6	60
200	86.40	173.2	75
250	108.00	231.0	100
300	130.00	288.7	125
350	151.60	346.5	150
400	172.80	404.2	175

NEW!

MCM now carries 8 x 10 pumps in stock!

8 x 10 x 14 1150 RPM

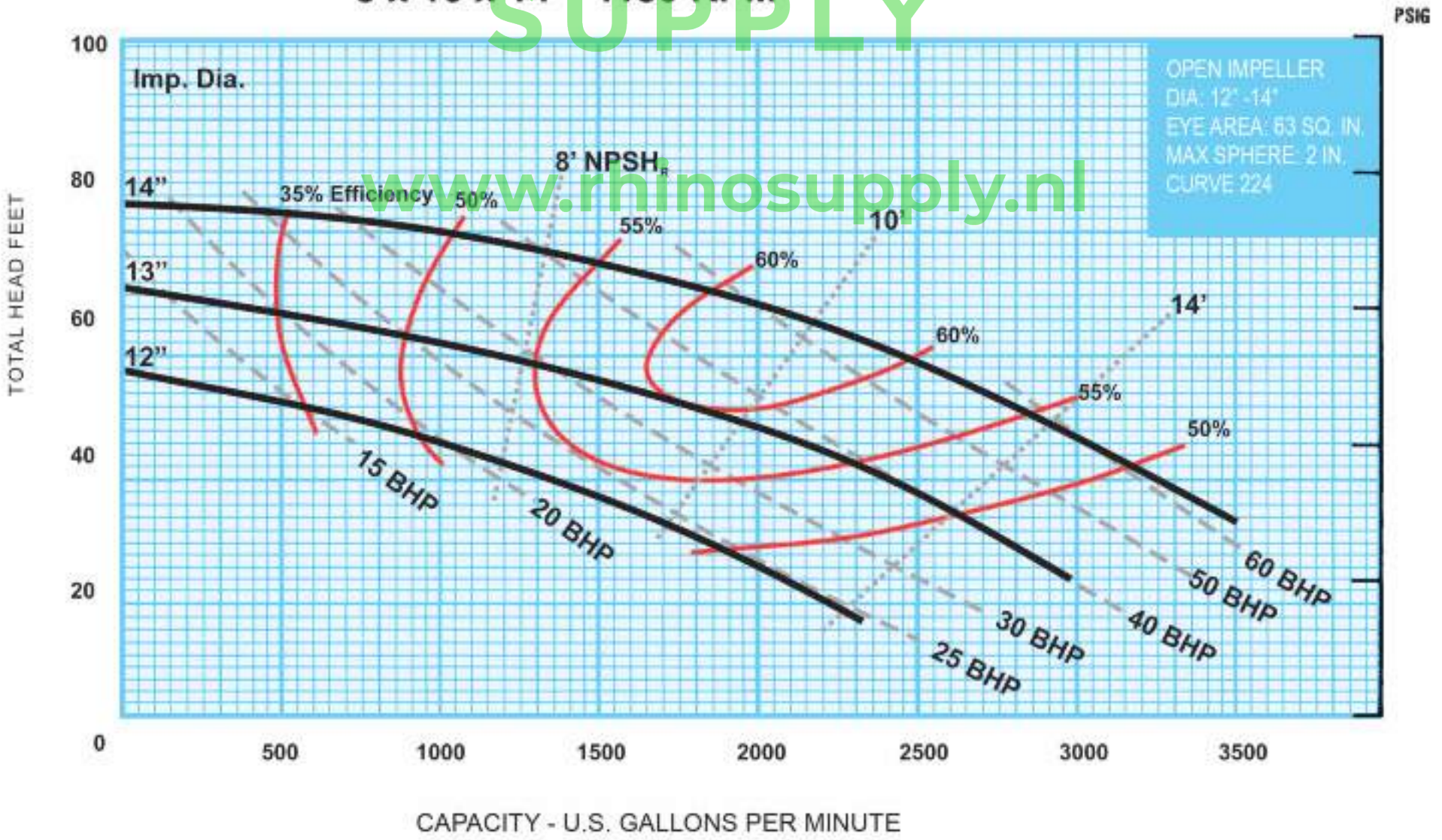

Curves show performance with clear water. If specific gravity is other than 1.0, curve HP must be corrected.

250 SERIES



8 x 10 x 14 1750 RPM

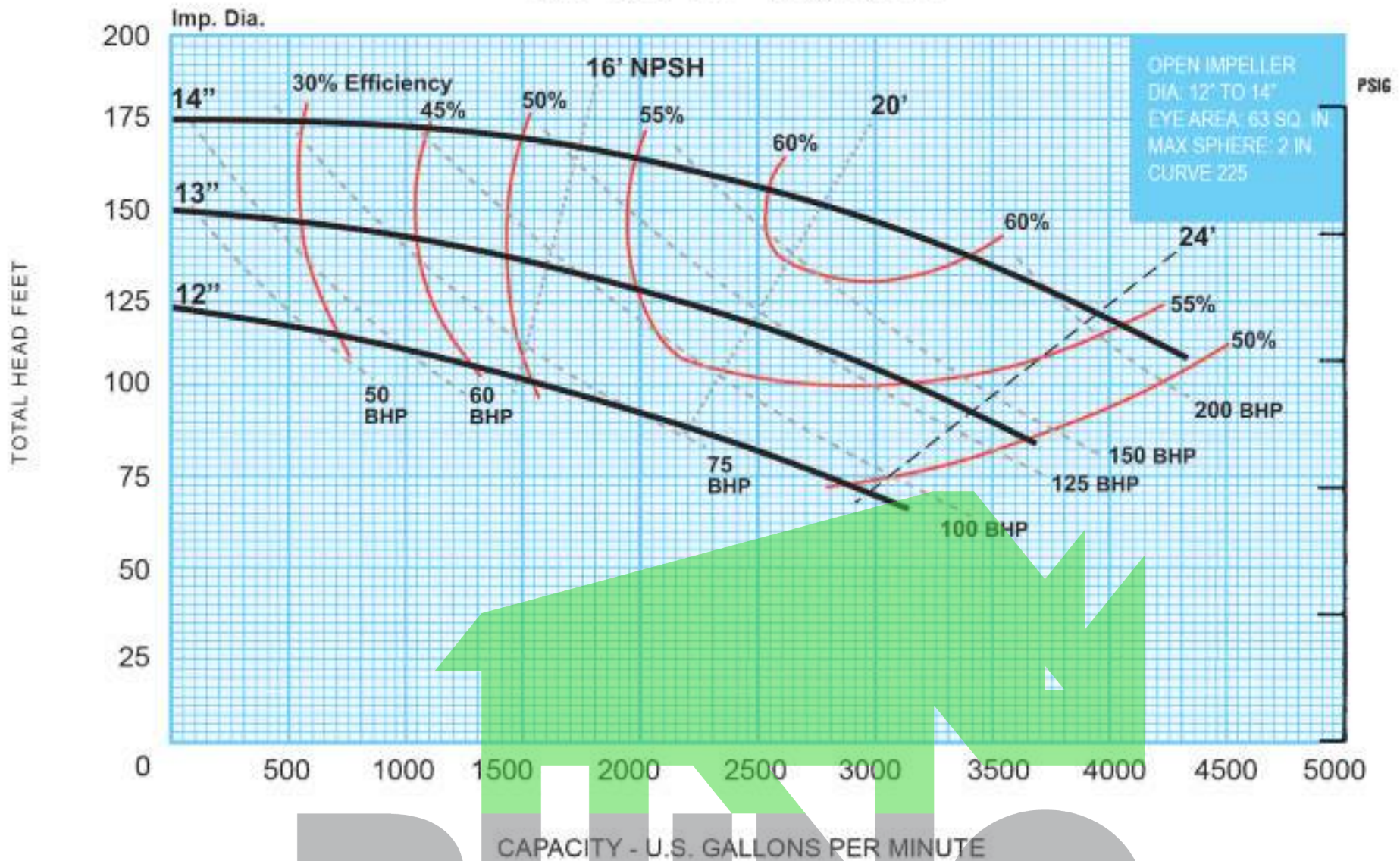

CAPACITY - U.S. GALLONS PER MINUTE

8 x 10 x 14 800-1800 RPM

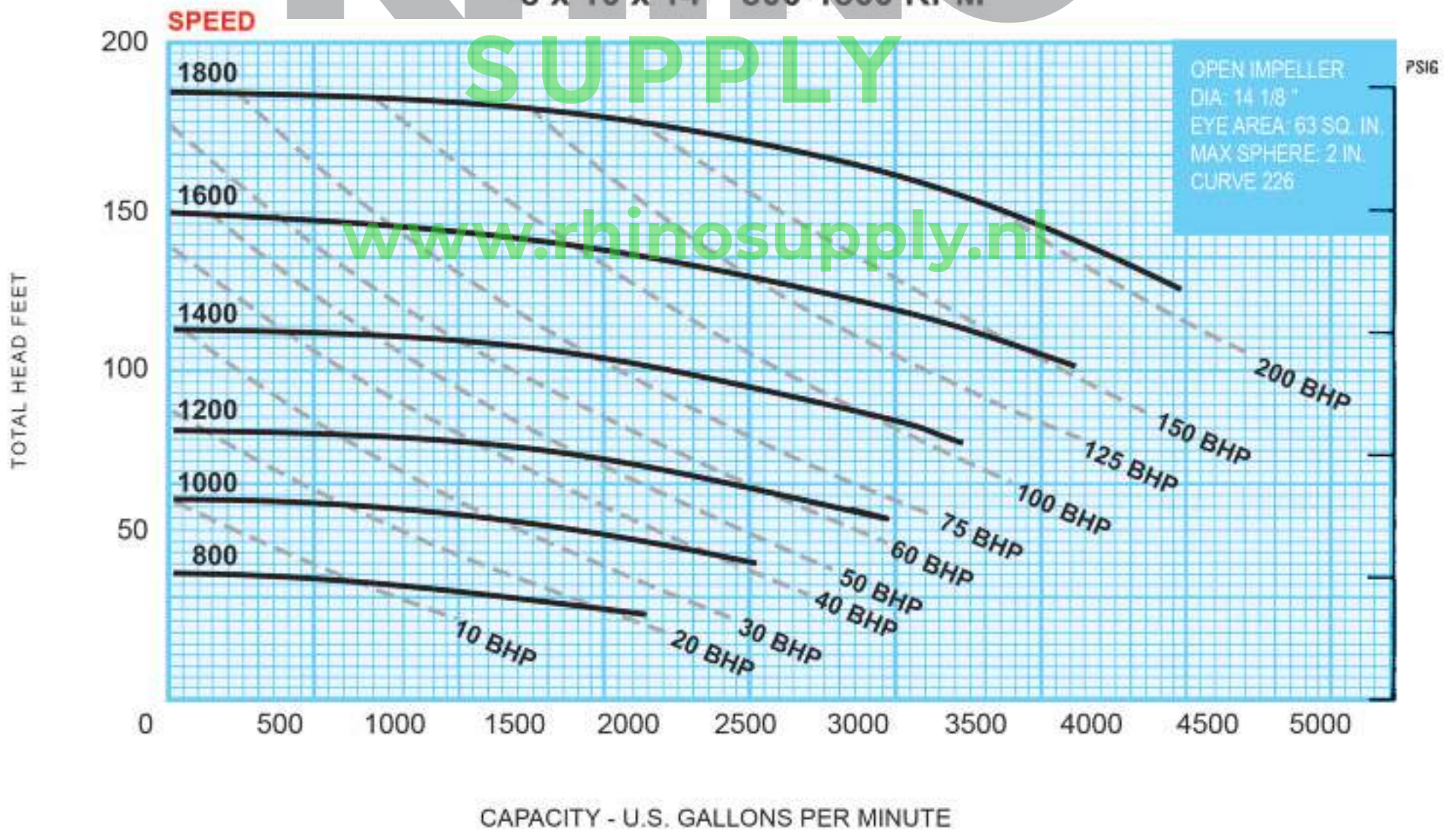

CAPACITY - U.S. GALLONS PER MINUTE

ELECTRIC MOTOR FRAME SIZES BY HP AND RPM						
HP	900 RPM	1200 RPM	1450 RPM	1800 RPM	2700 RPM	3600 RPM
1	182T	145T	145T	143T		
1.5	184T	182T	145T	145T	145T	143T
2	213T	184T	182T	145T	182T	182T
3	215T	213T	184T	182T	184T	182T
5	254T	215T	213T	184T	213T	184T
7.5	256T	254T	215T	213T	215T	213T
10	284T	256T	254T	215T	254T	215T
15	286T	284T	254T	254T	256T	254T
20	324T	286T	284T	256T	284TS	256T
25	326T	324T	286T	284T	286TS	284TS
30	364T	326T	324T	286T	324TS	286TS
40	365T	364T	326T	324T	326TS	324TS
50	404T	365T	364T	326T		326TS
60	405T	404T	365T	364T		
75		405T	405T	365T		
100			444T	405T		
125			445T	444T		
150			447T	445T		
200				447T		

Pump Packages

RHINO
DIMENSIONAL DATA
CHANNEL & FABRICATED BASE

SUPPLY

All Motors are based on 60 hz 1750 RPM (xxxx) = Maximum Frame Size*

Skids	Dimensions	118 Series	178 Series	250 Series
Horizontal Skids				
Channel Base Skids				
CB1	12 x 42	3-5 HP (184T)		
CB2	12 x 44	7.5 HP (213T)		
Fabricated Base Skids				
FB1	20 x 50	10 HP (215T)	5- 10 HP (215T)	5- 10 HP (215T)
FB2	20 x 60	15-30 HP (286T)	15 - 30 HP (286T)	15 - 30 HP (286T)
FB3	26 x 64	40-75 HP (365T)	40 - 75 HP (365T)	40 - 75 HP (365T)
FB3-100	26 x 72		100 HP (405T)	100 HP (405T)
FB4	36 x 72		150 HP (445T)	150-200 HP (447T)
FB5	38 x 84			250 HP
Vertical Mount, Belt Driven Skids				
OB1	17 x 36	10 Hp and less		
OB2	18.5x36		up to 100 HP	up to 100 HP
OB3	50 x 50		125-150 HP	125-150 HP

* **Note:** If using 50 hz, 1450 RPM, the same HP Motor is one frame size larger.
Example: 75HP @ 1450 RPM is a 100HP (405T) Frame Size. Therefore it requires the next skid size.

Conversion Data



GPM = .03 x BPD

SPECIFIC GRAVITY = $\frac{\text{Weight of Fluid in Lbs./Gal.}}{8.34}$

SPECIFIC GRAVITY = $\frac{\text{Pounds/Cu. Ft.}}{32.4}$

FEET HEAD = $\frac{\text{PSI} \times 2.31}{\text{Sp. Gr.}}$

PSI = $\frac{\text{Feet Head} \times \text{Sp. Gr.}}{2.31}$

BRAKE HORSEPOWER REQUIRED = Curve HP x Sp. Gr.

POUNDS PER GALLON = .133 x Pounds Per Cu. Ft.

FOR WATER, SP. GR. = 1.0

BARRELS/HOUR	BARRELS/DAY	GPM
4.2	100	3
10.5	250	7.5
21	500	15
31.5	750	22.5
42	1000	30
63	1500	45
83	2000	60
125	3000	90
208	5000	150
312	7500	225
420	10000	300
625	15000	450

MCM's Diesel Engine Packages!
RHINO
Engineered for High Performance
SUPPLY

www.rhinosupply.nl



MCM custom fabricates all types of Skid Packages for clients.
 Give us the opportunity to quote on your next requirement!

Engineering Data

VOLUME REQUIREMENTS FROM PUMPS FOR SOLIDS CONTROL EQUIPMENT

PRODUCT	VOLUME REQUIRED
3/4" Mud Gun Nozzle	80 GPM
1" Mud Gun Nozzle	140 GPM
1-1/2" Mud Gun Nozzle	300 GPM
2" Mud Gun Nozzle	550 to 600 GPM
6" Mud Hopper	550 GPM
Mechanical Brakes	40 to 50 GPM
Electrical Brakes	50 to 200 GPM
4" Desilter Cone	50 GPM
5" Desilter Cone	80 GPM
6" Desander Cone	125 GPM
8" Desander Cone	250 GPM
12" Desander Cone	450-500 GPM
Swaco® Degasser	400 GPM
Brandt® DG5 Degasser	500 GPM
Brandt® DG10 Degasser	1000 GPM

**RHINO
SUPPLY**

THEORETICAL DISCHARGE OF NOZZLES IN U.S. GALLONS PER MINUTE

HEAD*		VELOCITY OF DISCH. FL./Sec.	DIAMETER OF NOZZLE IN INCHES															
Lb.	Feet		3/8	1/2	5/8	3/4	7/8	1	1 1/8	1 1/4	1 3/8	1 1/2	1 5/8	2	2 1/4	2 1/2	2 3/4	3
10	23.1	38.60	13.3	23.6	36.9	53.7	72.4	94.5	120	148	179	213	289	378	479	591	714	851
15	34.6	47.25	16.3	28.9	45.2	65.0	88.5	116.0	147	181	219	260	354	463	585	723	874	1041
20	46.2	54.55	18.8	33.4	52.2	75.1	102.0	134.0	169	209	253	301	409	535	676	835	1009	1203
25	57.7	61.00	21.0	37.3	58.3	84.0	114.0	149.0	189	234	283	336	458	598	756	934	1128	1345
30	69.3	66.85	23.0	40.9	63.9	92.0	125.0	164.0	207	256	309	368	501	655	828	1023	1236	1473
35	80.8	72.20	24.8	44.2	69.0	99.5	135.0	177.0	224	277	334	398	541	708	895	1106	1335	1591
40	92.4	77.20	26.6	47.3	73.8	106.0	145.0	188.0	239	296	357	425	578	756	957	1182	1428	1701
45	103.9	81.80	28.2	50.1	78.2	113.0	153.0	200.0	253	313	379	451	613	801	1015	1252	1512	1802
50	115.5	86.25	29.7	52.8	82.5	119.0	162.0	211.0	267	330	399	475	647	845	1070	1320	1595	1900
55	127.0	90.50	31.1	55.3	86.4	125.0	169.0	221.0	280	346	418	498	678	886	1121	1385	1671	1991
60	138.6	94.60	32.5	57.8	90.4	130.0	177.0	231.0	293	362	438	521	708	926	1172	1447	1748	2085
65	150.1	98.30	33.8	60.2	94.0	136.0	184.0	241.0	305	376	455	542	737	964	1220	1506	1819	2165
70	161.7	102.10	35.2	62.5	97.7	141.0	191.0	250.0	317	391	473	563	765	1001	1267	1565	1888	2250
75	173.2	105.70	36.4	64.7	101.0	146.0	198.0	259.0	327	404	489	582	792	1037	1340	1619	1955	2330
80	184.8	109.10	37.6	66.8	104.0	150.0	205.0	267.0	338	418	505	602	818	1070	1354	1672	2020	2405
85	196.3	112.50	38.8	68.9	108.0	155.0	211.0	276.0	349	431	521	620	844	1103	1395	1723	2080	2480
90	207.9	115.80	39.9	70.8	111.0	160.0	217.0	284.0	359	443	536	638	868	1136	1436	1773	2140	2550
95	219.4	119.00	41.0	72.8	114.0	164.0	223.0	292.0	369	456	551	656	892	1168	1476	1824	2200	2625
100	230.9	122.00	42.1	74.7	117.0	168.0	229.0	299.0	378	467	565	672	915	1196	1512	1870	2255	2690

The actual quantity discharged by a nozzle will be less than above table. A well tapered smooth nozzle may be assumed to give 97 to 99% of the values in the tables.
*Head loss across nozzle.

Engineering Tables

Friction Losses in Pipe; C = (For Old Pipe)

V = Velocity, ft/sec.

h_f = Head Loss, Feet

U.S. Gallons per Minute	1 in. (1.049" I.D.)			1½ in. (1.610" I.D.)			2 in. (2.067" I.D.)			3 in. (3.068" I.D.)			U.S. Gallons per Minute
	V	$\frac{V^2}{2g}$	h_f	V	$\frac{V^2}{2g}$	h_f	V	$\frac{V^2}{2g}$	h_f	V	$\frac{V^2}{2g}$	h_f	
4	1.48	0.034	2.14										4
5	1.86	0.053	3.24										5
6	2.23	0.077	4.54										6
8	2.97	0.137	7.73	1.26	0.025	0.96							8
10	3.71	0.214	11.70	1.58	0.039	1.45							10
12	4.45	0.308	16.40	1.89	0.056	2.04							12
14	5.20	0.420	21.80	2.21	0.076	2.71							14
16	5.94	0.548	27.90	2.52	0.099	3.47							16
18	6.68	0.694	34.70	2.84	0.125	4.31							18
20	7.42	0.857	42.10	3.15	0.154	5.24	1.91	0.060	1.55				20
25	9.29	1.340	63.50	3.94	0.241	7.64	2.31	0.090	2.26				25
30	11.10	1.930	89.20	4.73	0.347	11.10	2.87	0.128	3.29				30
35	13.00	2.620	119.00	5.52	0.473	15.10	3.35	0.174	4.37				35
40	14.80	3.430	152.00	6.30	0.618	18.90	3.82	0.227	5.60				40
50				7.88	0.965	28.50	4.78	0.355	8.46	2.17	0.073	1.38	50
60				9.46	1.390	40.00	5.74	0.511	11.90	2.60	0.105	1.94	60
80				12.60	2.470	68.10	7.65	0.909	20.20	3.47	0.187	3.30	80
100				15.80	3.860	103.00	9.56	1.420	30.50	4.34	0.293	4.98	100
120							11.50	2.050	42.70	5.21	0.421	6.98	120
140							13.40	2.780	56.90	6.08	0.574	9.28	140
160							15.30	3.640	72.80	6.94	0.749	11.90	160
180							17.20	4.600	90.50	7.81	0.948	14.80	180
200							19.10	5.680	110.00	8.68	1.170	18.00	200
220							21.00	6.880	131.00	9.55	1.420	21.40	220
240							22.90	8.180	154.00	10.40	1.690	25.20	240
260							24.90	9.600	179.00	11.30	1.980	29.20	260
280							26.80	11.100	205.00	12.20	2.290	33.50	280
300							28.70	12.800	233.00	13.00	2.630	38.00	300
350										15.20	3.570	50.90	350
400										17.40	4.680	64.70	400
500										21.70	7.320	97.80	500
U.S. Gallons per Minute	4 in. (4.026" I.D.)			5 in. (5.047" I.D.)			6 in. (6.065" I.D.)			8 in. (7.981" I.D.)			U.S. Gallons per Minute
	V	$\frac{V^2}{2g}$	h_f	V	$\frac{V^2}{2g}$	h_f	V	$\frac{V^2}{2g}$	h_f	V	$\frac{V^2}{2g}$	h_f	
140	3.53	0.193	2.27	2.25	0.078	0.773							140
160	4.03	0.253	2.93	2.57	0.102	0.990							160
180	4.54	0.320	3.64	2.89	0.129	1.230							180
200	5.04	0.395	4.43	3.21	0.160	1.500	2.22	0.077	0.616				200
240	6.05	0.569	6.21	3.85	0.230	2.100	2.66	0.110	0.863				240
280	7.06	0.774	8.25	4.49	0.313	2.790	3.11	0.150	1.150				280
320	8.06	1.010	10.60	5.13	0.409	3.570	3.55	0.196	1.470				320
360	9.07	1.280	13.10	5.77	0.518	4.440	4.00	0.240	1.830				360
400	10.10	1.580	16.00	6.41	0.639	5.390	4.44	0.307	2.220	2.57	0.102	0.548	400
450	11.30	2.000	19.70	7.23	0.811	6.740	5.00	0.388	2.760	2.89	0.129	0.681	450
500	12.60	2.470	24.10	8.02	0.999	8.150	5.55	0.479	3.360	3.21	0.160	0.828	500
600	15.10	3.550	33.80	9.62	1.440	11.700	6.66	0.690	4.700	3.85	0.230	1.160	600
700	17.60	4.840	45.00	11.20	1.960	15.200	7.77	0.939	6.250	4.49	0.313	1.540	700
800	20.20	6.320	57.60	12.80	2.560	19.400	8.88	1.230	8.000	5.13	0.409	1.970	800
900	22.70	8.000	71.60	14.40	3.240	24.200	9.99	1.550	9.950	5.77	0.518	2.460	900
1000	25.20	9.870	87.00	16.00	4.000	29.400	11.10	1.920	12.100	6.41	0.639	2.980	1000
1200				19.20	5.760	41.100	13.30	2.760	16.900	7.70	0.920	4.180	1200
1400				22.50	7.830	54.700	15.50	3.760	22.500	8.98	1.250	5.560	1400
1600				25.70	10.200	70.100	17.80	4.910	28.900	10.30	1.640	7.120	1600
1800							20.00	6.210	35.900	11.50	2.070	8.850	1800
2000							22.20	7.670	43.600	12.80	2.560	10.800	2000
2400							26.60	11.000	61.100	15.40	3.680	15.100	2400

Engineering Tables

FRICITION LOSS IN PIPE FITTINGS IN TERMS OF EQUIVALENT FEET OF STRAIGHT PIPE

Nominal pipe size	Actual inside diameter d	Friction factor f	Gate valve — full open	90° elbow	45° elbow	Std. tee — thru flow	Std. tee — branch flow	Close return bend	Swing check valve — full open	Angle valve — full open	Globe valve — full open	Butter-fly valve	90° Welding elbow		Mitre bend	
													r/d = 1	r/d = 2	45°	90°
½	.622	.027	.41	1.55	.83	1.04	3.11	2.59	5.18	7.78	17.6					
¾	.824	.025	.55	2.06	1.10	1.37	4.12	3.43	8.86	10.30	23.3					
1	1.049	.023	.70	2.62	1.40	1.75	5.25	4.37	8.74	13.10	29.7					
1¼	1.380	.022	.92	3.45	1.84	2.30	6.90	5.75	11.50	17.30	39.1					
1½	1.610	.021	1.07	4.03	2.15	2.68	8.05	6.71	13.40	20.10	45.6					
2	2.067	.019	1.38	5.17	2.58	3.45	10.30	8.61	17.20	25.80	58.6	7.75	3.45	2.00	2.50	10.3
2½	2.469	.018	1.65	6.17	3.29	4.12	12.30	10.30	20.60	30.90	70.0	9.26	4.12	2.47	3.08	12.3
3	3.068	.018	2.04	7.67	4.09	5.11	15.30	12.80	25.50	38.40	86.9	11.50	5.11	3.07	3.84	15.3
4	4.025	.017	2.68	10.10	5.37	5.71	20.10	16.80	33.60	50.30	114.0	15.10	6.71	4.03	5.03	20.1
5	5.047	.016	3.36	12.60	6.73	8.41	25.20	21.00	42.10	63.10	143.0	18.90	8.41	5.05	6.31	25.2
6	6.065	.015	4.04	15.20	8.09	10.10	30.30	25.30	50.50	75.80	172.0	22.70	10.10	6.07	7.58	30.3
8	7.981	.014	5.32	20.00	10.60	13.30	39.90	33.30	63.30	99.80	226.0	29.20	13.30	7.98	9.98	39.9
10	10.020	.014	6.68	25.10	13.40	16.70	50.10	41.80	81.80	125.00	284.0	29.90	16.70	10.00	12.50	50.1
12	11.938	.013	7.96	29.80	15.90	19.90	59.70	49.70	99.70	149.00	338.0	34.80	19.90	11.90	14.90	59.7
14	13.124	.013	8.75	32.80	17.50	21.80	65.60	54.70	104.70	164.00	372.0	38.30	21.80	13.10	16.40	65.6
16	15.000	.013	10.00	37.50	20.00	25.00	75.00	62.50	125.00	188.00	425.0	31.30	25.00	15.00	18.80	75.0
18	16.876	.012	16.90	42.20	22.50	28.10	84.40	70.30	140.30	210.00	478.0	35.20	28.10	16.90	21.10	84.4
20	18.814	.012	12.50	47.00	25.10	31.40	94.10	78.40	156.40	235.00	533.0	39.20	31.40	18.80	23.50	94.1
24	22.628	.012	15.10	56.60	30.20	37.70	113.00	94.30	188.30	283.00	641.0	47.10	37.70	22.60	28.30	113.0
30	28.000	.011	18.70	70.00	37.30	46.70	140.00	117.00	234.00	351.00	854.0	57.00	46.70	28.00	35.00	140.0
36	34.000	.011	22.70	85.00	45.30	56.70	170.00	142.00	284.00	426.00	1054.0	67.00	56.70	34.00	43.00	170.0
42	40.000	.010	26.70	100.00	53.30	66.70	200.00	167.00	334.00	501.00	1254.0	77.00	66.70	40.00	50.00	200.0
48	46.000	.010	30.70	115.00	61.30	76.70	230.00	192.00	384.00	561.00	1454.0	87.00	76.70	46.00	58.00	230.0
L/D			8.00	30.00	16.00	20.00	60.00	50.00	150.00	340.0			20.00	12.00	15.00	60.00

Calculated from data in Crane Co. — Technical Paper 419.

Values of C for various types of pipe are given below together with the corresponding multiplier which should apply to the tabulated values of the head loss, h_f

TYPE OF PIPE	VALUES OF C									
	Range High best, smooth, well laid Low poor or corroded		Average value for good, clean, new pipe					Commonly used value for design purposes		
Cement - Asbestos	160-140		150					140		
Fibre	—		150					140		
Bitumastic-enamel-lined iron or steel centrifugally applied	160-130		148					140		
Cement-lined iron or steel centrifugally applied	—		150					140		
Copper, brass, lead, tin or glass pipe and tubing	150-120		140					130		
Wood-stove	140-110		120					110		
Welded and seamless steel	150-80		140					100		
Continuous-interior riveted steel (no projecting rivets or joints)	—		139					100		
Wrought-iron	150-80		130					100		
Cast-iron	150-80		130					100		
Tar-coated cast-iron	145-80		130					100		
Girth-riveted steel (projecting rivets in girth seam only)	—		130					100		
Concrete	152-85		120					100		
Full-riveted steel (projecting rivets in girth and horizontal seams)	—		115					100		
Vitrified	—		110					100		
Spiral-riveted steel (flow with lap)	—		110					100		
Spiral-riveted steel (flow against lap)	—		100					90		
Corrugated steel	—		60					60		
Value of C	150	140	130	120	110	100	90	80	70	60
Multiplier to correct tables	0.47	0.54	0.63	0.71	0.84	1.0	1.22	1.58	1.93	2.57

O'Drill MCM

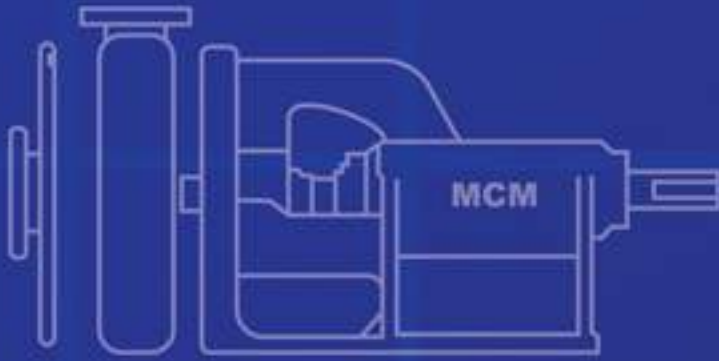

The Best Centrifugal Pump in the Oil Patch!



DISCLAIMER

The information and data contained in this catalog are accurate to the best of our knowledge, but are intended for general information only. Applications suggested for the materials are described only to help readers make their own evaluation, and are neither guarantees nor to be construed as expressed or implied warranties of suitability for these or other applications. O'DRILL MCM makes no warranty either expressed or implied beyond that stipulated in O'DRILL MCM Standard Terms and Conditions of Sale.

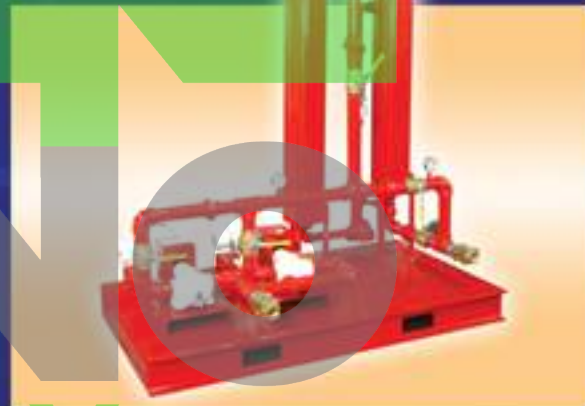

Manufacturers of:

CENTRIFUGAL PUMPS • VALVES • DESILTERS • DESANDERS • MUD CLEANERS • SHALE SHAKERS • SCREENS



CORPORATE OFFICE & MANUFACTURING FACILITY

www.rhinosupply.nl

RHINO
SUPPLY

5055 CRANSWICK RD. • HOUSTON, TX 77041

Tel: (713) 541.2020 Fax: (713) 541.9090 • Toll Free: 1 800 255.6263

website: odrillmcm.com

e-mail: sales@odrillmcm.com